

KVH Industries, Inc.

TracVision® A9



Installation Guide

TracVision A9 Installation Guide

This guide explains how to install the TracVision A9 satellite TV antenna system on a vehicle. Operation instructions are provided in the Quick Start Guide.

Installation Steps

- | | | | |
|--|----|--|----|
| 1. Inspect Parts and Get Tools | 3 | 8. Connect Power | 22 |
| 2. Mount the Antenna | 4 | 9. Turn On the System..... | 24 |
| 3. Wire the Antenna | 11 | 10. Access the Web Interface | 25 |
| 4. Plan the TV-Hub Installation..... | 16 | 11. Connect to an Existing Network | 26 |
| 5. Mount the TV-Hub..... | 17 | 12. Secure the Wi-Fi Connection..... | 27 |
| 6. Wire the Antenna to the TV-Hub..... | 18 | 13. Set Up the System..... | 28 |
| 7. Wire the Receivers..... | 19 | 14. Educate the Customer..... | 30 |

Appendices

- | | | | |
|--------------------------------------|----|--------------------------------------|----|
| A. Installing an IP AutoSwitch | 32 | B. Using a DIRECTV Coax Network..... | 35 |
|--------------------------------------|----|--------------------------------------|----|

Who Should Install the System?

To ensure a safe and effective installation, KVH recommends that a KVH-authorized technician install the TracVision antenna. KVH-authorized technicians have the tools and electronics expertise necessary to install the system. To find a technician near you, visit www.kvh.com/wheretogetservice.

Technical Support

If you need technical assistance, please contact KVH Technical Support:

Phone: +1 401 847-3327

Email: support@kvh.com

(Mon.-Fri., 9 am-6 pm; Sat., 9 am-2 pm ET, -5 GMT)

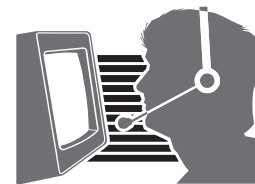

Important Safety Information



This icon indicates a danger, warning, or caution notice. Be sure to read these carefully to avoid injury.



WARNING

Risk of Electric Shock

To avoid electric shock, do not open the TV-Hub chassis enclosure. There are no user-serviceable parts inside.



WARNING

Risk of Electric Shock

If any component of the TracVision system becomes damaged and/or no longer functions normally, disconnect it from vehicle power, secure it from unintended operation, and contact KVH Technical Support (see [“Technical Support” on page 1](#)). All repairs or modifications must be performed by a trained, KVH-certified technician. If you are a KVH-certified technician, you still must contact KVH Technical Support prior to conducting any repairs or modifications to the equipment.



WARNING

Risk of Explosion

Do not operate the TV-Hub (or any other electrical device) in an environment where flammable gases, vapors, or dusts are present. In addition, do not operate the TV-Hub in an environment with a temperature outside its 5° F to 131° F (-15° C to 55° C) temperature range.



WARNING

Risk of Electric Shock

Failure to ground the TracVision system properly to the vehicle’s ground will cause an unsafe floating ground condition, risking potentially lethal electric shock. See [“Connect Power” on page 22](#) for details on the proper grounding of the equipment.



CAUTION

Avoid Driver Distraction

Do not connect the TracVision system to video screens that are visible to the vehicle driver. Driver distraction can result in an accident with personal injury or death resulting.

1 Inspect Parts and Get Tools

Before you begin, follow these steps to ensure you have everything needed to complete the installation.

- a. Unpack the box and ensure it contains everything shown on the Kitpack Contents List. Save the packaging for future use.
- b. Carefully examine all of the supplied parts to ensure nothing was damaged in shipment.
- c. Gather the tools and materials listed below to complete the installation.
 - Flat-head and Phillips screwdrivers
 - Hex socket drivers
 - Wire cutters
 - Adhesive tape and scribe or pencil
 - Light hammer and center punch
 - Measuring tape
 - 1/2" (12.7 mm) hole saw
 - Electric drill with a 5/32" and 1/8" drill bits
 - Construction adhesive and fasteners suitable for mounting the antenna to the roof
 - 7/16" open-end wrench
 - 7/16" open-end torque wrenches set to 20 in.-lbs (2.25 N-m) and 15 in.-lbs (1.7 N-m)
 - Silicone sealant or equivalent
 - If you cut the antenna cable to length: Augat IT1000 crimp tool (*KVH part no. 19-0242*), see [page 18](#).
 - Satellite TV receiver(s)/DVRs for your desired service (see Figure 2)
 - Multimeter
 - Wi-Fi-enabled laptop PC with the latest TracVision software and satellite library downloaded from the KVH Partner Portal (www.kvh.com/partners), or Apple® iOS or Android™ smartphone/tablet with the TracVision TV/RV mobile app

Figure 1: TracVision A9 System Components

Antenna

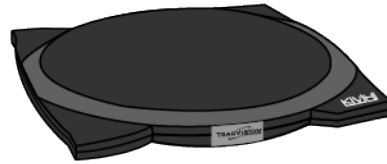

TV-Hub



Figure 2: KVH-Validated Receivers

DIRECTV*	DISH Network*
H20	311
H21	211
H22	211k
H23	211z
H24	Wally
H25	
HR21, HR21 Pro	
HR22	
HR23	
HR24	

* List is subject to change. For information on connecting different receiver models, contact KVH Technical Support.

2 Mount the Antenna

To mount the antenna, first remove the shipping restraints with heavy-duty wire cutters (see Figure 3). Then follow the steps for your particular mounting option:

- Rack Mount see below
- Roof Mount page 8

Mount the Antenna to the Roof Rack

- a. Attach each of the four mounting brackets to the antenna base using two 1/4"-20 x 3/4" hex socket screws as shown in Figure 4. (A bolt is factory-installed in the base between the bracket holes.)
- b. Position the roof rack crossbars 35.5" (89.4 cm) apart, measured center-to-center. Ensure that the crossbars are securely fastened to the vehicle (see Figure 5).

IMPORTANT!
Be sure the roof rack's crossbars are secured in place and are sturdy enough to support the 49.5 lb (22.5 kg) antenna.

Figure 3: Shipping Restraint Locations on Antenna Base

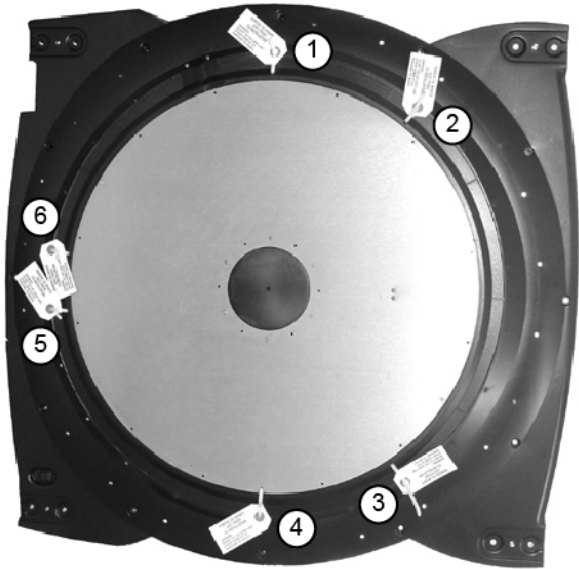

Figure 4: Attaching the Mounting Brackets

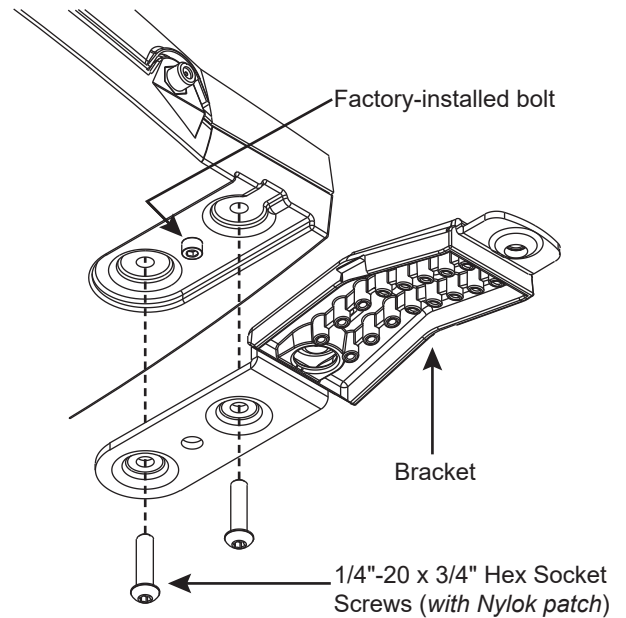
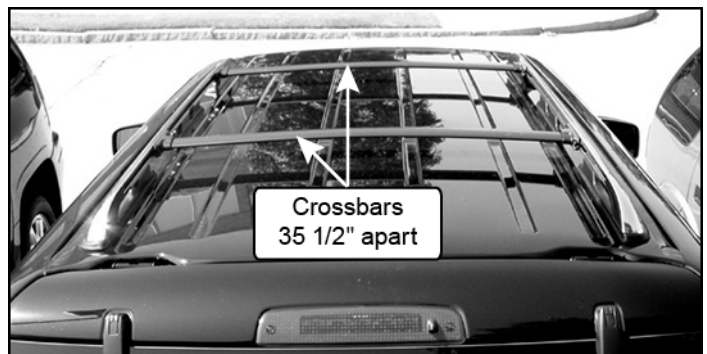

Figure 5: Roof Rack Crossbars



2 Continued Mount the Antenna

- c. With an assistant's help, gently place the antenna onto the roof rack with the cable connector facing the rear of the vehicle. All four brackets should rest on top of the roof rack's crossbars (see Figure 6 and Figure 7).
- d. Each bracket contains several pairs of pegs (see Figure 4 on page 4). These pegs allow you to place two rubber cushions in different positions to best fit the vehicle's style of crossbars. Try out the various cushion positions until you find the best fit for your installation. The more surface area of the cushions pressing against the crossbar, the better the fit.

Figure 6: Placing the Antenna on the Crossbars



Figure 7: Antenna Connector Facing Rear of Vehicle

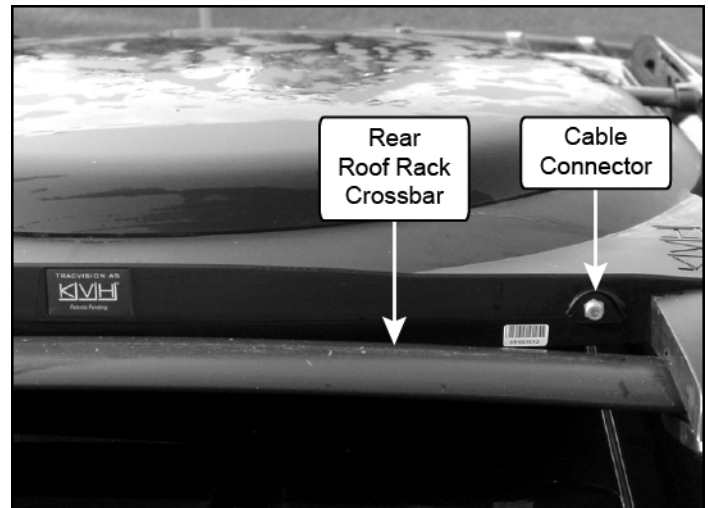

2 Continued Mount the Antenna

- e. With the cushions installed in the brackets, the bottom of the antenna should rest above the vehicle's roof. If the antenna's base touches the roof, you will need to add a spacer under each bracket to raise the antenna higher off the crossbars.

If spacers are needed, follow steps f and g on the next page to install a spacer under each bracket as shown in Figure 8. Otherwise, skip to step h on page 7.

- f. Remove the #8-32 x 3/8" screws and washers securing the factory-installed plastic spacer to the metal bracket (see Figure 9).
- g. Insert a second spacer from the kitpack between the original spacer (which holds the rubber cushions) and the bracket. Secure both spacers to the bracket using the supplied #8-32 x 7/8" screws and the original washers that you removed in step f (see Figure 10).

IMPORTANT!

If you installed extra spacers, and the bottom of the antenna still contacts the roof, KVH recommends that you either use the roof mount option on [page 8](#) or replace the roof rack with an aftermarket model that offers greater clearance.

Figure 8: Positioning Rubber Cushions For Best Fit

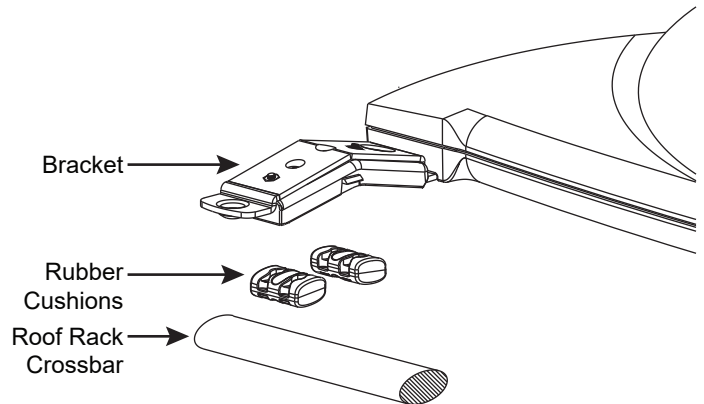

Figure 9: Adding a Second Spacer to the Bracket (If Needed)

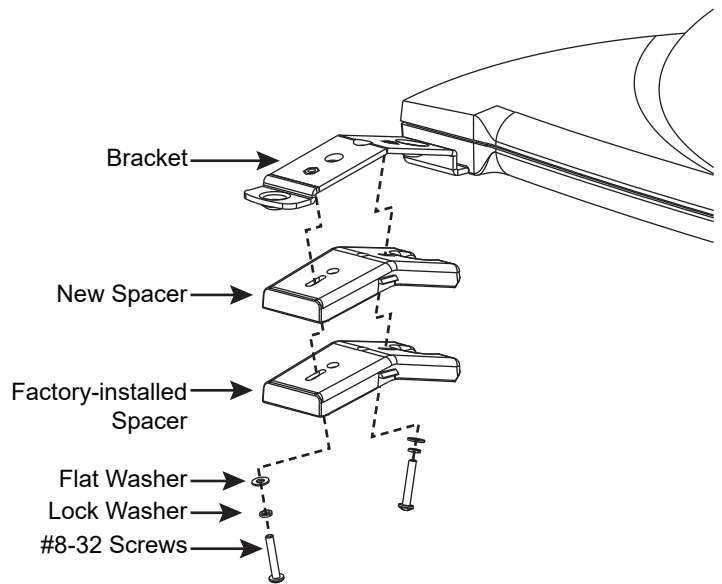
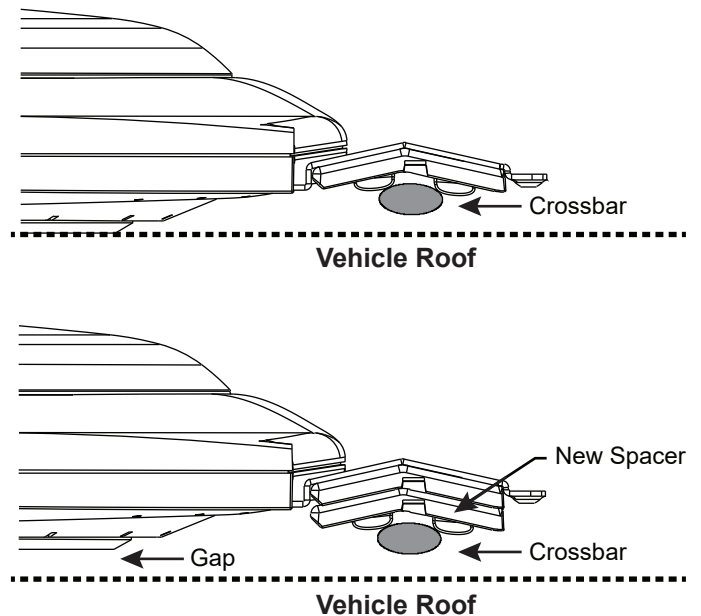

Figure 10: Using Spacers to Raise the Antenna Above the Roof



2 Continued Mount the Antenna

- h. Secure each mounting bracket to the roof rack with a retaining plate, two hex socket screws, and two jam nuts (*supplied in kit*). Use a 1.75" screw at the end of each bracket and use a 2" screw at the base of each bracket (see Figure 11). After securing all four brackets to the crossbars, verify that all cushions (two within each bracket) are pressed firmly against the crossbars providing a solid grip.
- i. Attach a protective cover onto each clamp. The covers simply snap into place at the sides of the brackets (see Figure 12).

IMPORTANT!

Two different sizes of covers are provided in the kitpack. Install the two larger covers on the rear brackets and the smaller covers on the front brackets.

Figure 11: Securing the Brackets to the Crossbars

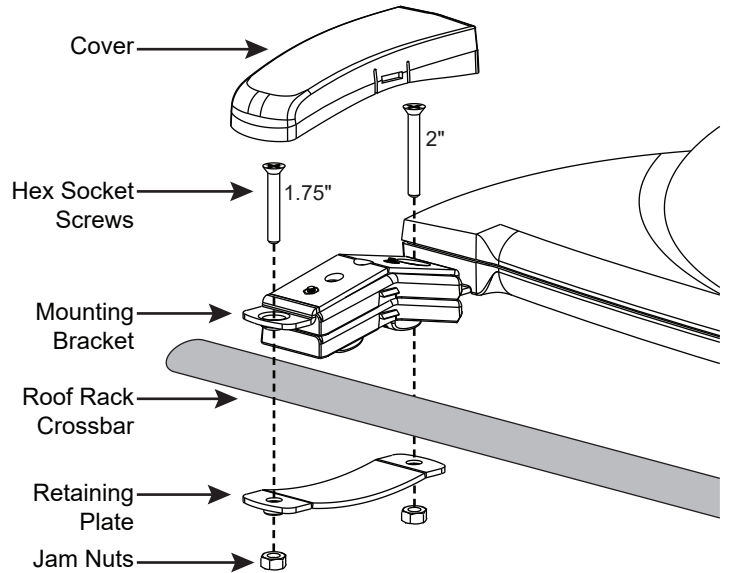
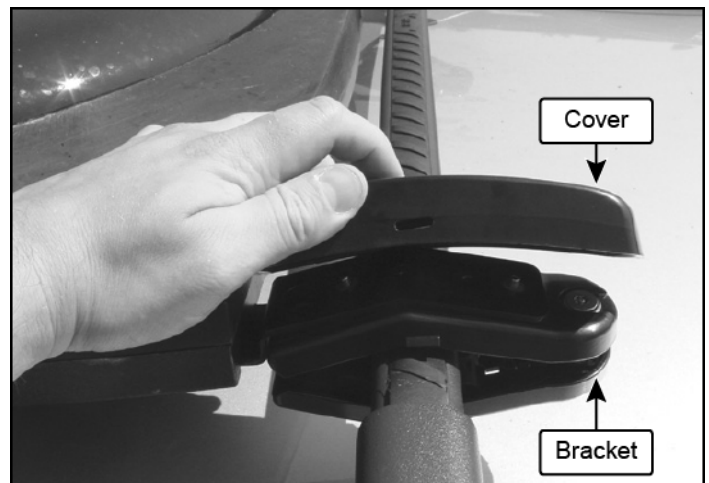

Figure 12: Attaching the Cover



2 Continued Mount the Antenna

If you are mounting the antenna directly to the roof, follow the steps below.

Mount the Antenna Directly to the Roof

- Attach each of the four mounting brackets to the antenna base using two 1/4"-20 x 3/4" hex socket screws (see Figure 13). A bolt is factory-installed in the base between the bracket holes.
- Place the metal mounting plates onto the vehicle's roof (do not attach yet!). Ensure the nut bar swivels easily within each mounting plate (see Figure 14.)
- Lift the skirt on the four rubber mounting blocks, then place the blocks onto the mounting plates. Align with the threaded holes in the nut bar (see Figure 15).

Figure 13: Attaching the Mounting Brackets

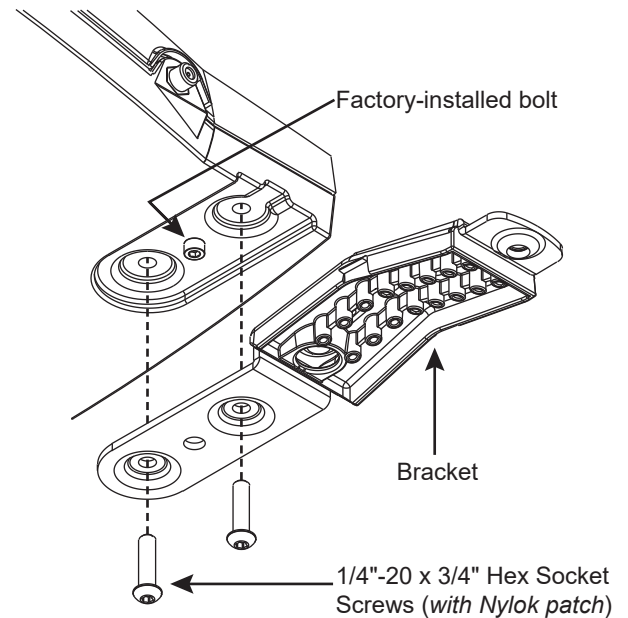

Figure 14: Metal Mounting Plate with Nut Bar

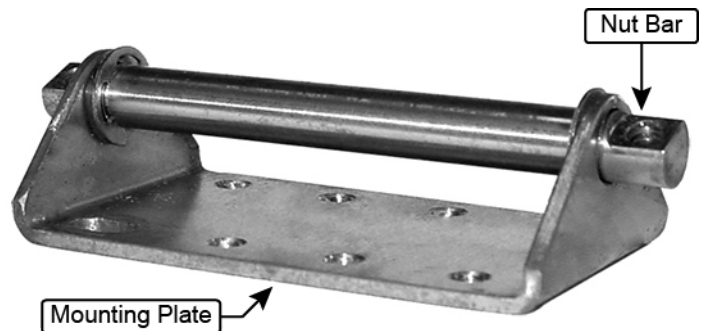
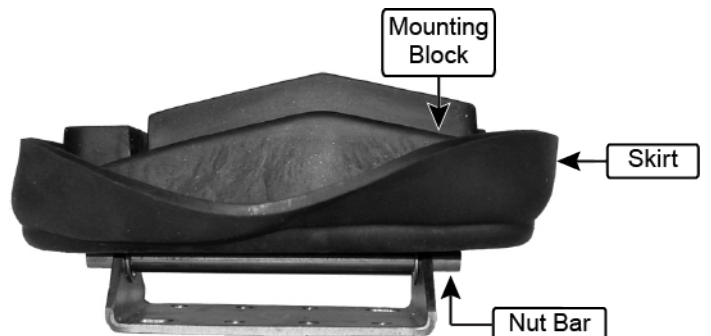

Figure 15: Rubber Mounting Block Placed Onto Mounting Plate



2 Continued Mount the Antenna

d. With an assistant's help, position the antenna onto the centerline of the vehicle's roof with a mounting block and mounting plate under each bracket (see Figure 16). Make sure the antenna's connector faces the rear of the vehicle.

e. The bottom of the antenna should rest above the vehicle's roof. If the antenna's base is above and not touching the roof, skip to step i.

If the antenna's base is touching the roof, STOP the installation. Call KVH at 401-847-3327 to order the Spacers Kit (part no. 72-0221) and follow steps f-h to install a spacer under each bracket to raise the antenna higher.

f. Remove the #8-32 x 3/8" screws and washers securing the factory-installed plastic spacer to the metal bracket.

g. Insert a second spacer from the Spacers Kit between the original spacer and the bracket. Secure both spacers to the bracket using the #8-32 x 7/8" screws (supplied in kit) and the original washers that you removed in step f.

h. Place a rubber spacer (supplied in kit) onto the end of each rubber mounting block (see Figure 18).

i. Make sure the antenna is positioned on the centerline of the roof in the desired location and resting firmly on the mounting blocks. With the antenna in place, mark the roof along the outside edges of the mounting plates using a pencil or scribe.

j. Set aside the antenna and the mounting blocks.

k. Attach the four mounting plates to the roof at the locations you outlined in step i. Be sure to use fasteners appropriate to the roof's construction.

IMPORTANT!

Due to the variation in vehicle roof construction, consult with the vehicle manufacturer to determine the safest fastening method.

Figure 16: Positioning an Antenna Bracket Onto a Mounting Block

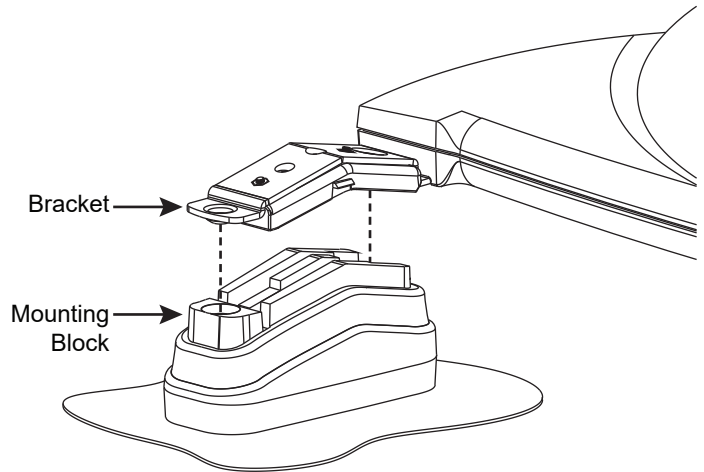

Figure 17: Adding Spacers (If Needed for Extra Height)

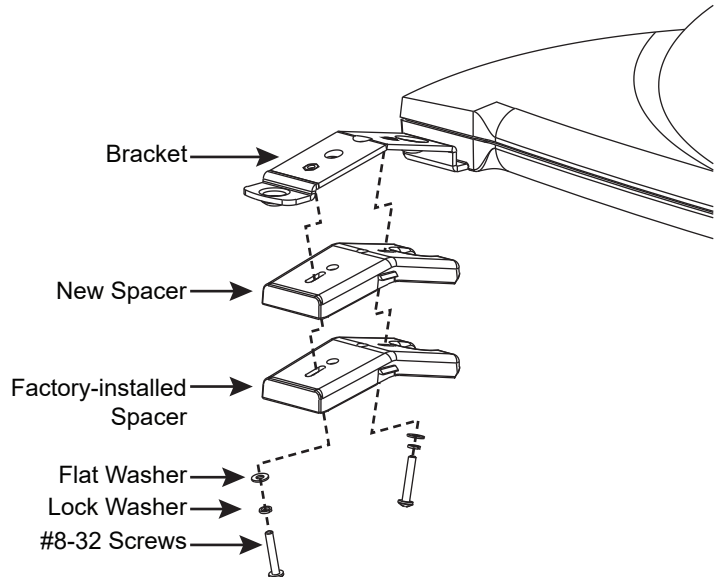
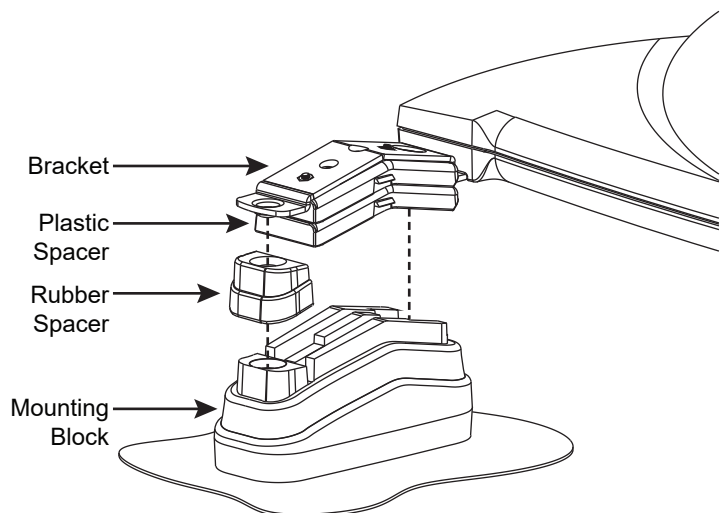

Figure 18: Attaching Bracket With Spacers



2 Continued Mount the Antenna

- l. Seal all fasteners with silicone sealant or equivalent.
- m. Place the rubber mounting blocks back onto the mounting plates.
- n. Place the antenna onto the mounting blocks. Align the holes in the antenna brackets with the holes in the mounting blocks.
- o. At each bracket, insert two hex socket screws (*supplied in kit*) through the antenna bracket and mounting block and into the nut bar. Use a 2.25" screw at the end of each bracket and a 2.5" screw at the base. **If you added a spacer, use the 2.5" and 2.75" screws supplied in the Spacers Kit instead (use the shorter screw at the end).** Tighten the screws to secure.
- p. Flip down the skirt on each rubber mounting block to hide the mounting plates.
- q. Attach a protective cover onto each bracket. The covers simply snap into place at the sides of the brackets.

IMPORTANT!

Two different sizes of covers are provided in the kitpack. Install the two larger covers on the rear brackets and the smaller covers on the front brackets.

Figure 19: Securing the Antenna to the Roof

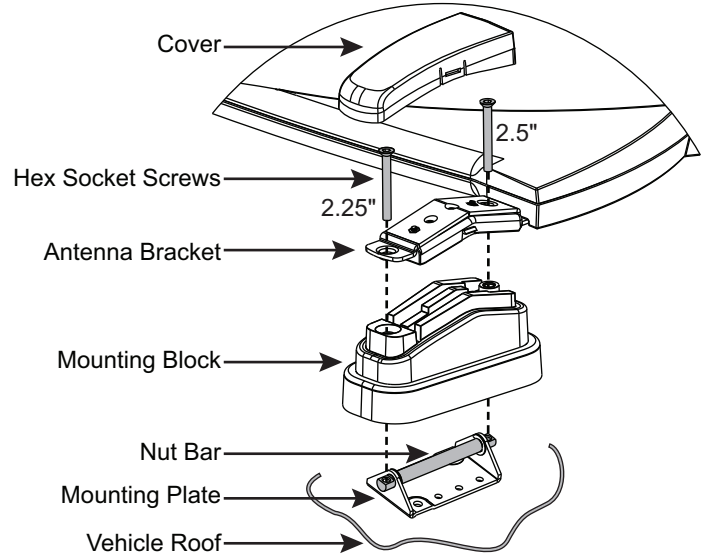
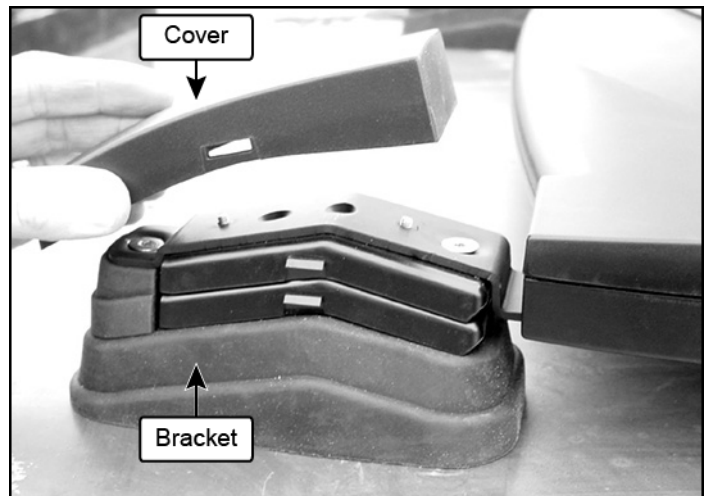

Figure 20: Attaching the Cover



3 Wire the Antenna

To wire the antenna, first route the antenna cable. You can route the antenna cable directly through the roof or from behind the hatch (SUVs and minivans) by following these steps:

- Roof Routing see below
- Hatch Routing page 14

Route the Cable Through the Roof

- a. Clean and dry the connectors on the antenna cable and the rear of the antenna.

	CAUTION
Observe the safe handling instructions in the Material Safety Data Sheet (MSDS) provided with the silicone grease.	

- b. Fill half of the inner body of the antenna cable's connector with the supplied silicone grease (the end with the rubber boot).
- c. Connect and SLOWLY hand-tighten the antenna cable (the end with the rubber boot) to the antenna, allowing the grease to diffuse and settle into the entire space within the connector.
- d. Make sure the antenna cable is hand-tightened all the way into the connector. Then tighten it with a 7/16" torque wrench set to 20 in.-lbs, or a 7/16" wrench for 1/4 turn (see Figure 21).
- e. Wipe off any excess grease from the outside of the connector.
- f. Slide the rubber sealing boot up the cable until it covers the antenna cable connector to help protect it from weather (see Figure 21).

Figure 21: Connecting the Antenna Cable to the Antenna

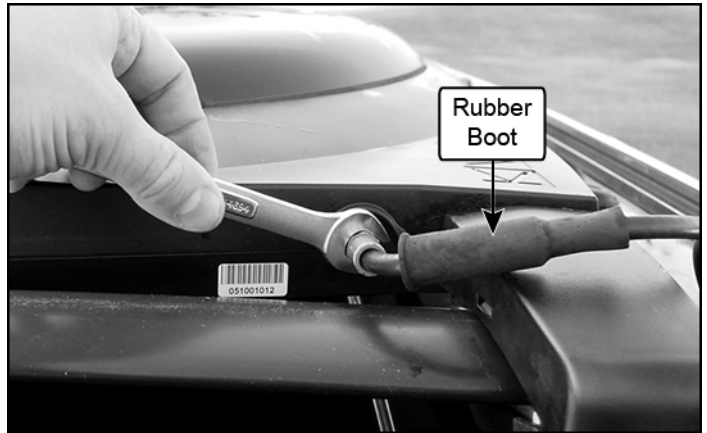

3 Continued Wire the Antenna

- g. Choose a location on the roof for the 1/2" (12.7 mm) diameter cable access hole. Inside the vehicle, remove the headliner to access the underside of the roof where you will be cutting out the hole.

IMPORTANT!

Techniques for removing the headliner vary from vehicle to vehicle. Only a trained automotive installer should remove the headliner. KVH is not liable for damage caused by improper headliner removal.

- h. Using a 1/2" (12.7 mm) hole saw, cut out the cable access hole in the vehicle's roof and smooth the edges of the hole to protect the cable (see Figure 22).
- i. Center the backing plate over the cable access hole to locate the three fitting mounting holes. Use a center punch to mark the hole locations.
- j. Set aside the backing plate, then use a 5/32" drill bit to drill the three fitting mounting holes (see Figure 22).
- k. Insert the antenna cable (with preinstalled cable fitting) into the access hole (see Figure 23). Inside the vehicle, pass the cable through the backing plate and route the cable to the TV-Hub.

IMPORTANT!

Do not kink the cable. Maintain a bend radius of at least 4.5" (11.5 cm). A tighter bend may disrupt the TV signal and degrade performance.

Figure 22: Locating the Cable Access and Fitting Mounting Holes

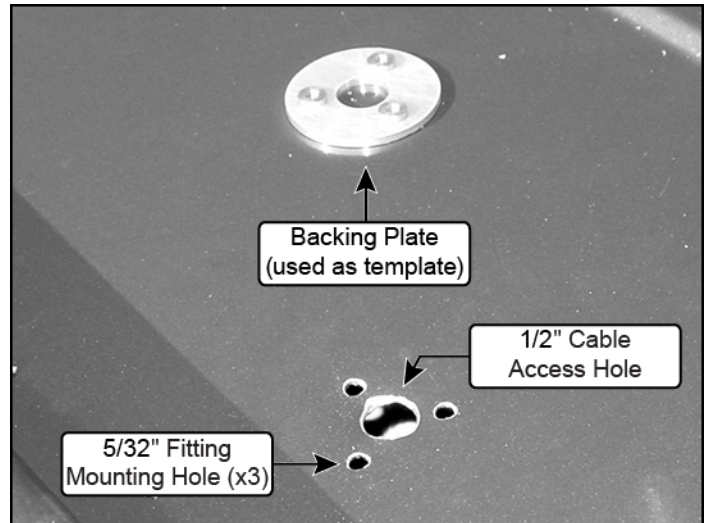
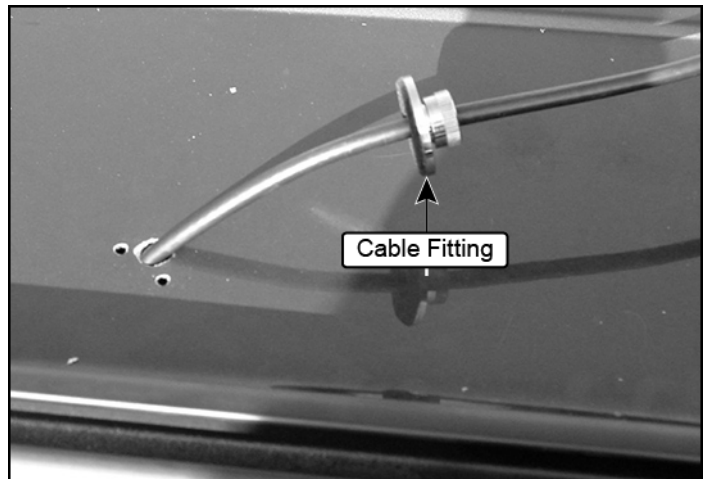

Figure 23: Cable Routed Into Vehicle Through Access Hole



3 Continued Wire the Antenna

- l. Move the fitting down the cable until it covers the cable access hole, flush to the vehicle's roof. Line up the fitting's three mounting holes with the three 5/32" holes drilled in the roof. Apply silicone sealant or equivalent to the holes and insert the supplied #6-32 x 5/8" screws (see Figure 24).
- m. Secure the #6-32 x 5/8" screws to the backing plate inside the vehicle (see Figure 25).
- n. Hand-tighten the fitting's clamping nut onto the cable until you're unable to move the cable back and forth, ensuring a watertight seal (see Figure 24).
- o. Use tie-wraps (*supplied in kit*) to secure the antenna cable to the roof rack, if necessary (see Figure 26).

Figure 24: Fitting Mounted to Roof

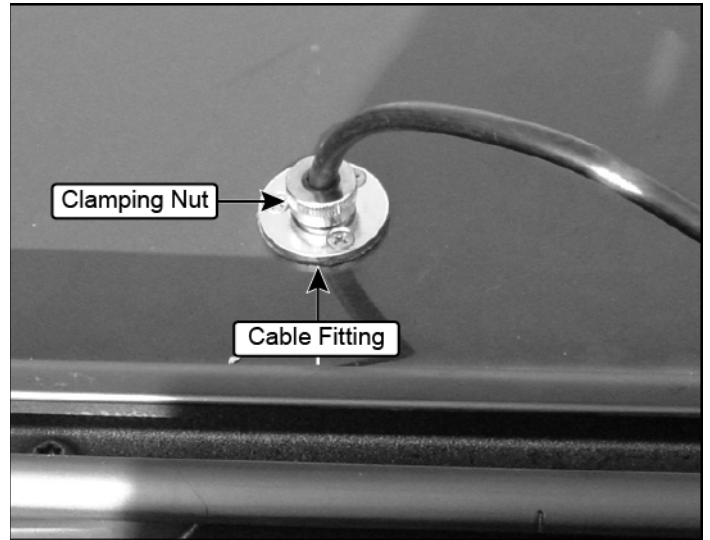

Figure 25: Backing Plate (Inside Vehicle)

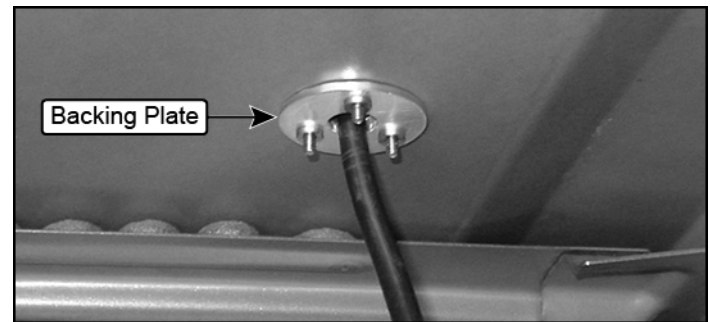
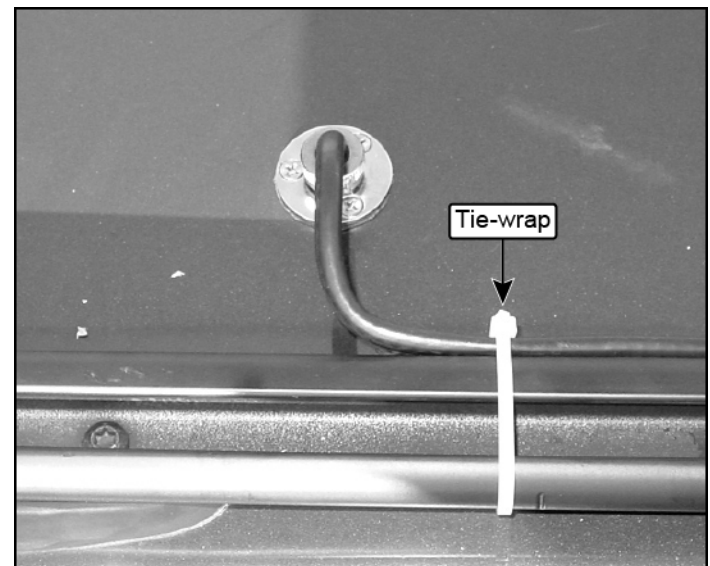

Figure 26: Securing the Cable to the Roof Rack



3 Continued Wire the Antenna

Route the Cable Behind the Hatch

If the gap in the vehicle's hatch hinge is wide enough when closed to allow the antenna cable to pass without pinching it, maintaining a 4.5" (11.5 cm) bend radius, you can insert the antenna cable through the gap and into the vehicle. You can follow the steps below to route the antenna cable behind the hatch.

- a. Move the steel fitting down the length of the antenna cable to the end opposite the rubber boot. You'll need to connect the end of the cable with the rubber boot to the antenna. You will not need to use the fitting; simply keep it attached to the end of the cable inside the vehicle.
- b. Starting from inside the vehicle, pass the antenna cable through the gap in the hatch hinge (see Figure 27).
- c. Clean and dry the connectors on the antenna cable and the rear of the antenna.



CAUTION

Observe the safe handling instructions in the Material Safety Data Sheet (MSDS) provided with the silicone grease.

- d. Fill half of the inner body of the antenna cable's connector with the supplied silicone grease.

Figure 27: Cable Routed Behind Rear Hatch

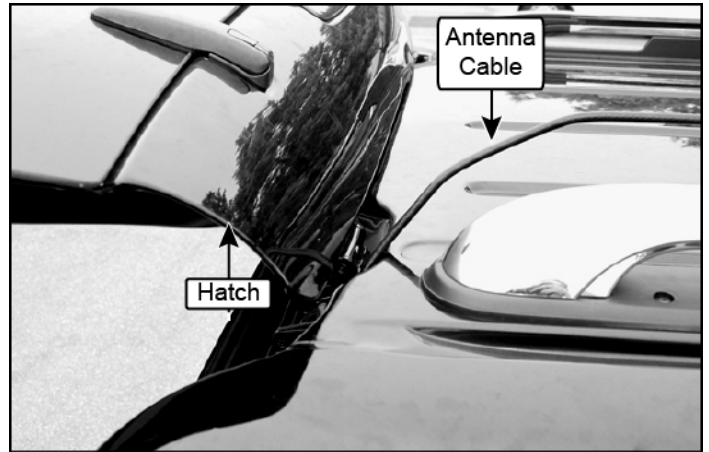

3 Continued Wire the Antenna

- e. Connect and SLOWLY hand-tighten the antenna cable to the antenna, allowing the grease to diffuse and settle into the entire space within the connector.
- f. Make sure the antenna cable is hand-tightened all the way into the connector. Then tighten it with a 7/16" torque wrench set to 20 in.-lbs, or a 7/16" wrench for 1/4 turn (see Figure 28).
- g. Wipe off any excess grease from the outside of the connector.
- h. Slide the rubber sealing boot up the cable until it covers the antenna cable connector. This boot will help protect it from weather (see Figure 28).
- i. Use tie-wraps (*supplied in kit*) to secure the cable to the roof rack, if necessary.

IMPORTANT!

Do not kink the cable. Maintain a bend radius of at least 4.5" (11.5 cm). A tighter bend may disrupt the TV signal and degrade performance.

Figure 28: Connecting the Antenna Cable to the Antenna

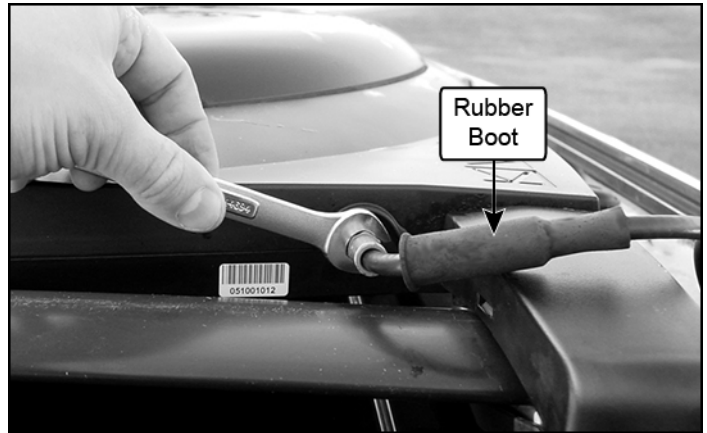

4 Plan the TV-Hub Installation

Consider the following TV-Hub installation guidelines.

- Select a mounting location in a dry, well-ventilated area inside the vehicle away from any heat sources.
- Do not install the TV-Hub in an area surrounded by metal or near any electrical devices that emit RF noise.
- The TV-Hub can be mounted horizontally or vertically on a flat surface (see Figure 29).
- Be sure the TV-Hub LED lights will be visible to the user.
- Select a location that will provide adequate clearance for the TV-Hub dimensions (see Figure 29).
- Leave enough room behind the rear panel (horizontal mount) or below the rear panel (vertical mount) to accommodate connecting the cables and making service loops within the proper bend radius.
- If you plan to use the TV-Hub's Wi-Fi connections, ensure the TV-Hub mounting location provides adequate Wi-Fi reception.
- If you plan to connect the TV-Hub to the vehicle's local area network (LAN), choose a location near an available Ethernet port.

NOTE: A template showing the exact locations of the TV-Hub mounting holes and the dimensions between them is provided in the Welcome Kit. Installation details are provided in ["Mount the TV-Hub" on page 17](#).

Figure 29: TV-Hub Dimensions

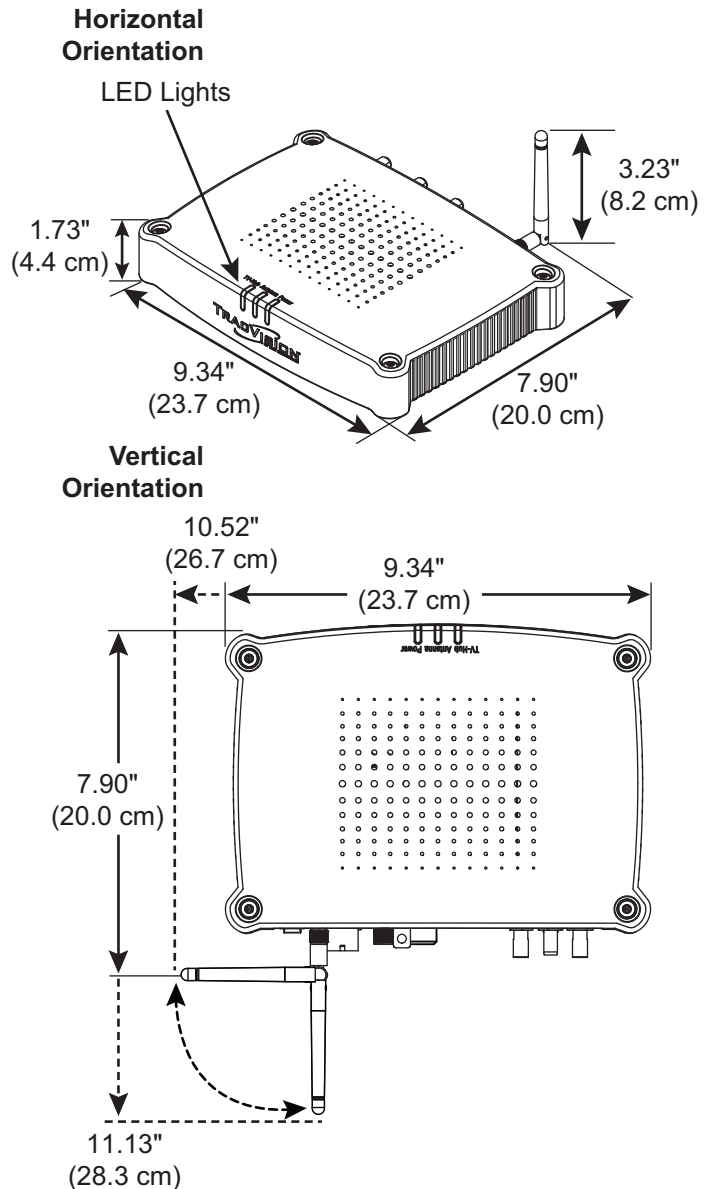

5 Mount the TV-Hub

Follow these steps to install the TV-Hub inside the vehicle.

IMPORTANT!

Before continuing, locate the serial number on the bottom of the TV-Hub and record it on the Installation Checklist (supplied in the Welcome Kit) for future reference.

- Tape the mounting template in the location selected for the TV-Hub. Punch holes at each of the two keyhole locations and at the mounting tab location.
- Remove the template.
- Drill a 1/8" (3 mm) hole at the three hole locations you marked in step a.
- Install a #8 Phillips thread-forming screw partway into one of the keyhole holes leaving a small gap for hooking the TV-Hub onto it. Use the thickness (2.5 mm) of the M10 washer (supplied in kit) as a gauge for the size gap to leave.
- Repeat step d for the other keyhole.
- Peel off the backing on the adhesive-backed washer (supplied in kit) and place it over the mounting tab hole (see Figure 30).
- Align the wide part of the TV-Hub's keyholes, as shown in Figure 31, over the screws, then slide downwards to secure the screws into the narrow part of the keyholes.
- Press the rear mounting tab of the TV-Hub onto the adhesive washer and install the third #8 Phillips thread-forming screw in the mounting tab hole.

Figure 30: TV-Hub Mounting Template

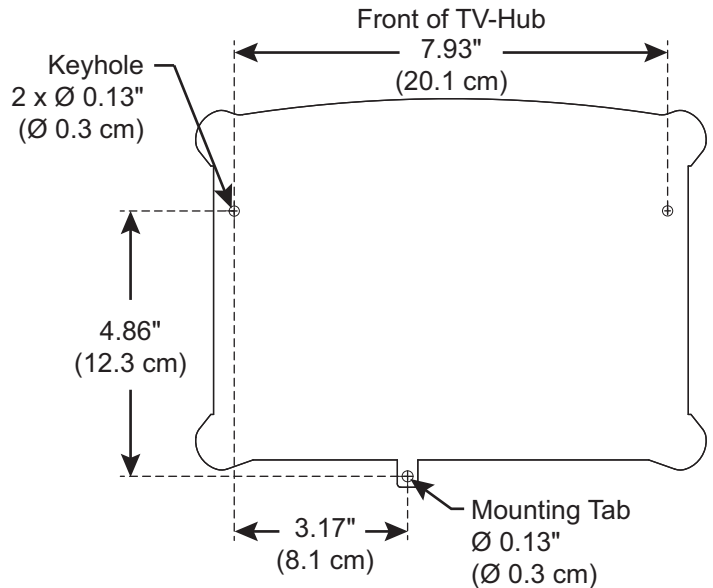
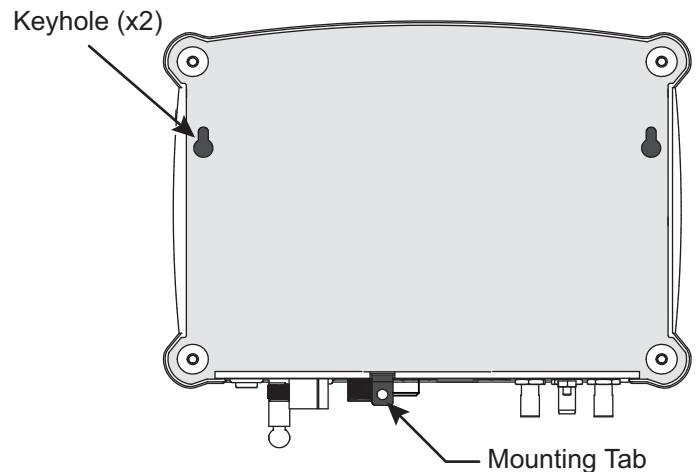

Figure 31: TV-Hub Keyholes and Mounting Tab



6 Wire the Antenna to the TV-Hub

Follow these steps to connect the antenna to the TV-Hub.

IMPORTANT!

Be sure to leave an adequate service loop, approximately 8" (20 cm) of slack, in the cable for easy serviceability.

- a. Prepare the antenna cable. If the cable is too long, you may either coil the excess cable inside the vehicle, use an alternative KVH-recommended cable, or cut the end of the cable to the desired length. Refer to the table in Figure 33 for antenna cable requirements.

IMPORTANT!

Low-quality, poorly terminated, or improperly installed RF cables are the most common cause of system problems. Terminate all RF cables with high-quality "F" connectors using the proper stripping/crimping tools, exactly to the manufacturer's specifications.

- b. Connect the antenna cable from the antenna to the "Antenna" jack on the TV-Hub (see Figure 32).

IMPORTANT!

Do not connect anything other than the antenna's RF1 cable to the "Antenna" jack. The TV-Hub supplies voltage that will damage other devices, such as multiswitches, receivers, DVRs, etc.

- c. Hand-tighten the antenna cable until it is all the way into the "Antenna" jack. Then tighten it with a 7/16" torque wrench set to 15 in.-lbs, or a 7/16" wrench 1/8 turn.

Figure 32: TV-Hub Antenna Connection

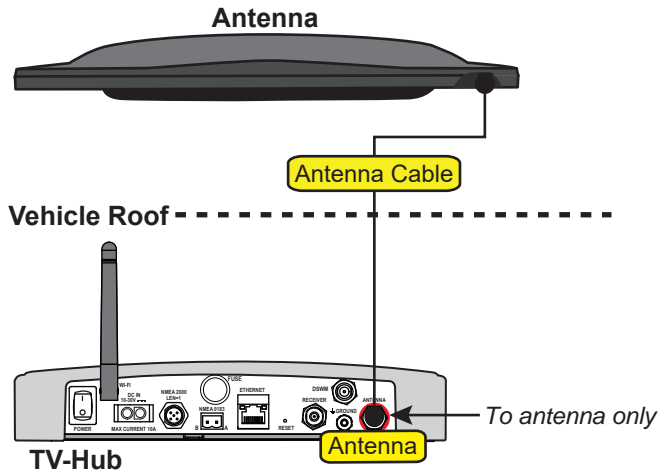

Figure 33: RF Cable Requirements

Up to 100 ft (30 m) Cable Run	
Cable	RG-6 (KVH part no. 32-0417-0100)
Connector	Belden SNS1P6 (KVH part no. 23-0170)
Tools	Augat IT1000 (KVH part no. 19-0242)
Strip Lengths	<p> ← 0.04" (1.02 mm) dia. ← 0.25" (6.35 mm) ← 0.5" (12.7 mm) </p>

Note: LMR-400-75 is a suitable substitute.

7 Wire the Receivers

The steps for connecting the customer's receiver(s) to the TracVision system and setting them up depends upon the customer's satellite TV service (see Figure 34).

Follow the steps in the applicable section below to wire the receivers. Then connect the receiver(s) to the customer's television(s).

DIRECTV (SWM) page 20

DISH Network page 21

Figure 34: TV-Hub Receiver Connections

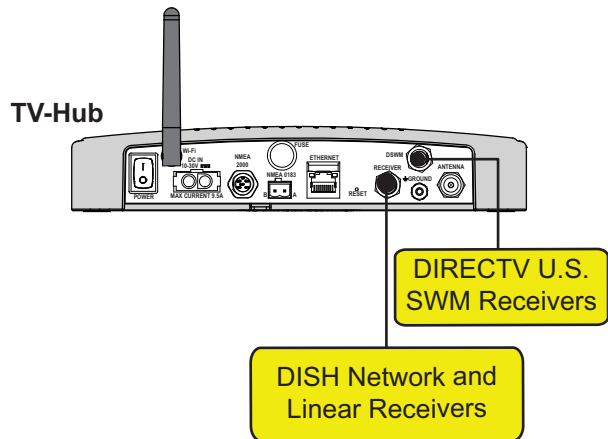

7 Continued Wire the Receivers

DIRECTV – SWM Wiring

Follow these steps to connect DIRECTV SWM receivers to the TracVision system.

Connecting 1 SWM Receiver

Connect an RF cable from the “DSWM” jack on the TV-Hub to the “Satellite In” jack on the receiver/DVR (see Figure 35).

Connecting Up to 8 SWM Receivers (or 13 Tuners)

- Connect an RF cable from the “DSWM” jack on the TV-Hub to the “SWM” input on the SWM splitter (*supplied in kit*) (see Figure 36).
- Connect the SWM splitter’s outputs to the “Satellite In” jack on the receivers/DVRs. You can connect up to 8 SWM devices that add up to 13 or fewer tuners. Refer to Figure 36 to determine the tuners consumed by each type of device.
- Terminate any unused outputs on the SWM splitter with the supplied 75Ω terminators and verify all connections are tight.

IMPORTANT!

If you need to receive local channels on the 119W satellite, and you want the antenna to automatically switch between the 101W and 119W satellites, you need to use the DIRECTV coax network. See Appendix B on [page 35](#) for details.

Figure 35: Wiring 1 DIRECTV SWM Receiver

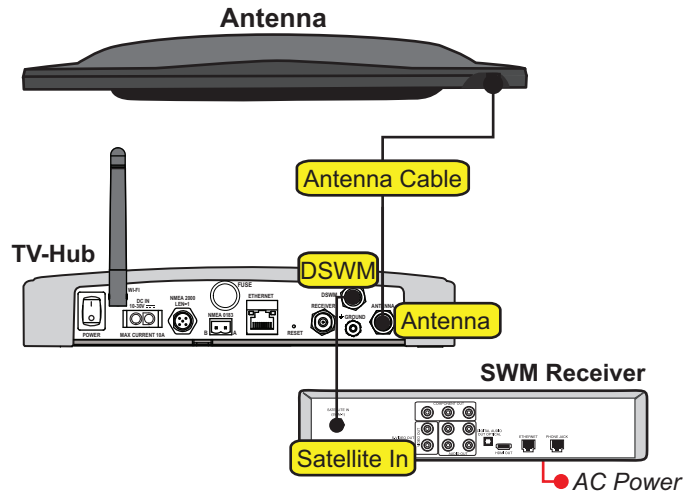
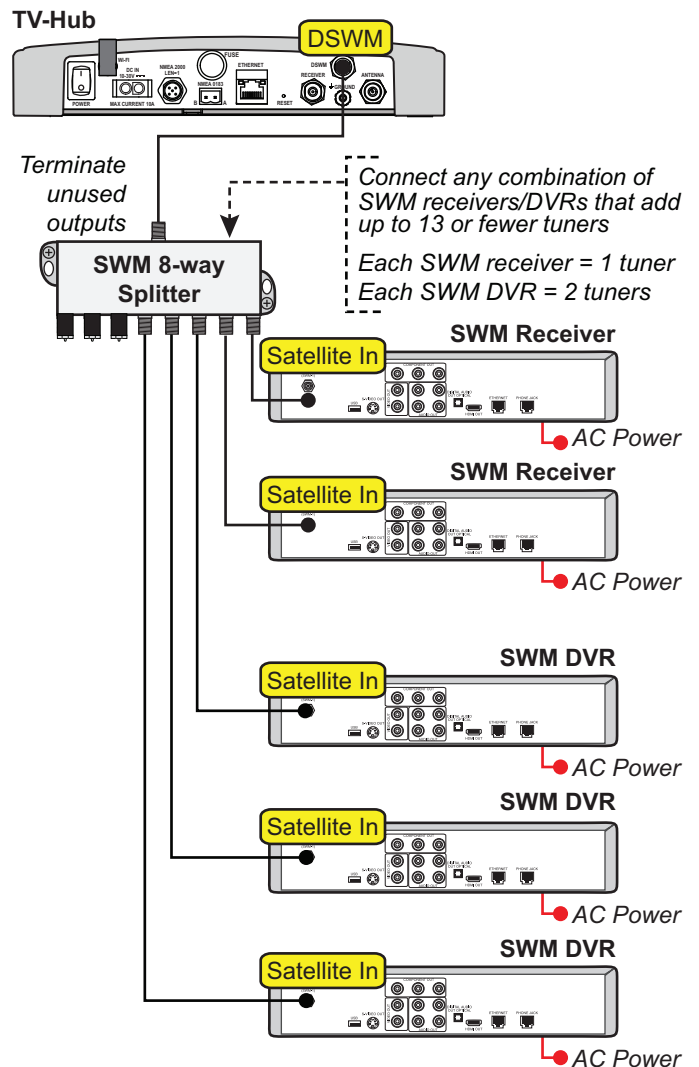

Figure 36: Wiring Up to 8 SWM Devices



7 Continued Wire the Receivers

DISH Network Wiring

Follow these steps to connect DISH Network receivers to the TracVision system.

IMPORTANT!

Receivers must be DISH Pro-compatible. Look for the DISH Pro logo on the box.

Connecting 1 Receiver

Connect an RF cable from the “Receiver” jack on the TV-Hub to the “Satellite In” jack on the receiver (see Figure 37).

Connecting 2 or More Receivers

- Connect an RF cable from the “Receiver” jack on the TV-Hub to the “Antenna” jack on the DC block splitter (*supplied in kit*).
- Connect the “Primary” jack on the DC block splitter to the “Satellite In” jack on the first receiver. *This receiver will be able to control satellite selection in Automatic satellite switching mode.*
- If you need to connect just a second receiver, connect the “Secondary” jack on the splitter to the “Satellite In” jack on the second receiver (see Figure 38).

If you need to connect three or more receivers, connect the “Secondary” jack on the splitter to the “18V” port on a multiswitch (see Figure 39). KVH offers a 4-output passive multiswitch (KVH part no. 72-0676) and an 8-output active multiswitch (KVH part no. 72-0677).

- When using a multiswitch, connect the multiswitch outputs to the “Satellite In” jacks on the receivers.

IMPORTANT!

To enable any of the additional receivers to control satellite selection in Automatic satellite switching mode, install an optional IP Autoswitch (KVH part no. 72-0634) in-line with its RF input. See Appendix A on [page 32](#) for details.

Figure 37: Wiring 1 DISH Receiver

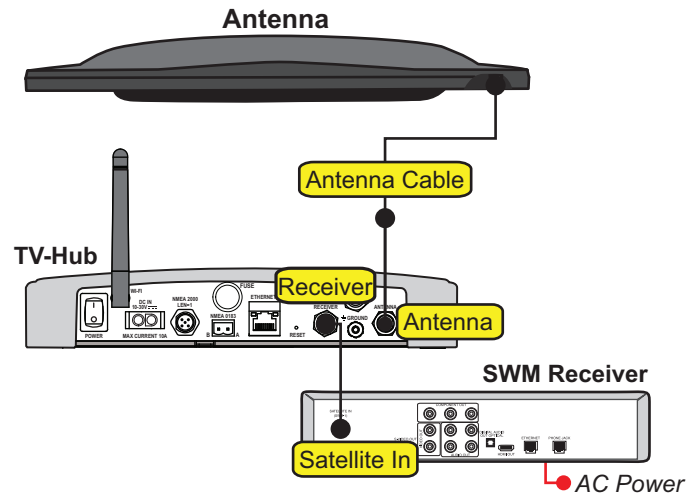

Figure 38: Wiring 2 DISH Receivers

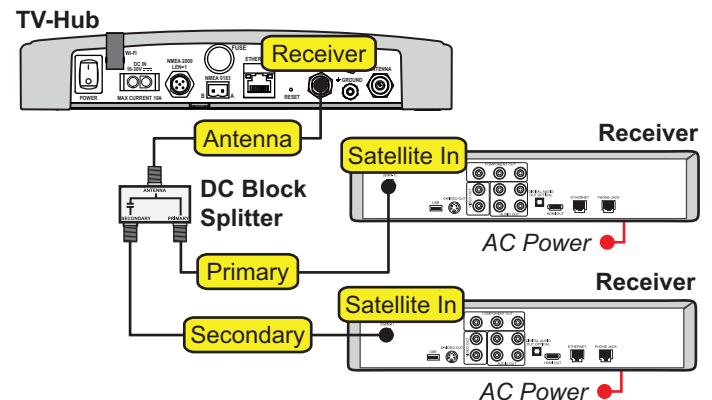
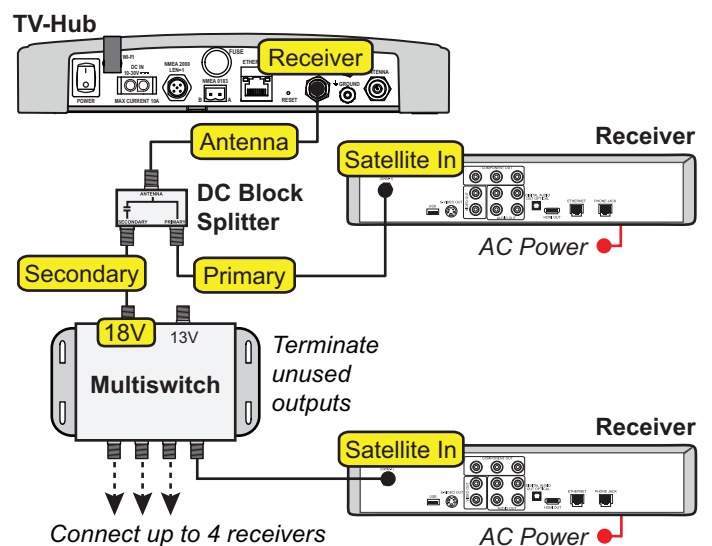

Figure 39: Wiring 3+ DISH Receivers



8 Connect Power

Before connecting power, be sure the vehicle is properly grounded.

Grounding Requirements

Proper grounding of the TracVision system to the vehicle's ground is mandatory for electromagnetic compatibility (EMC) and safety regulatory compliance. It protects the equipment from electrostatic discharges (ESD) and prevents interference with other electronic equipment.

Follow these steps to ground the system.

- a. Connect the hoop of the grounding wire (supplied in kit) to the "Ground" screw on the rear panel of the TV-Hub (see Figure 40).
- b. Connect the other end of the grounding wire to the vehicle's common ground, such as a pillar ground screw.

Figure 40: TV-Hub Grounding Connection

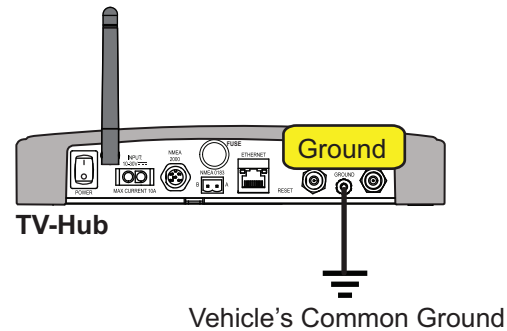

WARNING

Failure to ground the TracVision system properly to the vehicle's ground will cause an unsafe floating ground condition, risking damage to the antenna and electric shock, potentially resulting in DEATH. In a floating ground condition, the difference between the equipment's chassis ground and the vehicle's ground can measure well over 100 volts, when it normally should not exceed 2 volts. Therefore, always measure the difference in potential between chassis ground and the vehicle's ground to make certain that there is no dangerous floating ground condition.

Connect Power to the System

NOTE: When powering up a SWM configuration, apply power to all other system components before powering up the receivers and DVRs (tuners are assigned SWM channels during startup).

Follow the steps on the next page to connect power to the TracVision system.



CAUTION

For your own safety, shut down vehicle power before you connect the power wires.

8 Continued Connect Power

- Before you connect the power wires, turn off vehicle power and test the circuit to ensure no power is present.
- Make sure that the ground wire from the TV-Hub has been connected to ground as described on the previous page (see Figure 41).

IMPORTANT!

Do not use a cigarette lighter as a power supply. All power connections must be hard wired.

- Connect the individual power wires to a dedicated 12 VDC circuit. Connect the negative (black) wire to common ground (DC return) and connect the positive (red) wire to clean +12 VDC vehicle power (10-30 VDC is required at the TV-Hub), but not directly to the battery.

NOTE: An optional 24 VDC AC-DC power supply (5 A, 120 W) is available from KVH (part no. 72-0669).

- Check for proper grounding by using a multimeter to measure the AC and DC voltages between the ground stud on the rear of the TV-Hub and the vehicle's ground. The measured voltage should be less than 2 VAC and 2 VDC. **A higher voltage indicates a dangerous floating ground condition.**
- Reapply vehicle power.
- Repeat step d with the TV-Hub powered on, looking for the same measured result.



WARNING

If you measure 2 volts or greater between the ground stud on the rear of the TV-Hub and the vehicle's ground, notify the vehicle's electrician or authorized representative immediately. This is a dangerous condition. Do not touch the TV-Hub rear panel or connect anything to it until the problem is fixed.

Figure 41: TracVision System Power

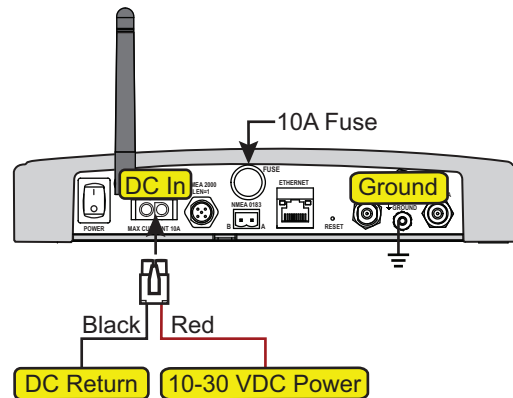

9 Turn On the System

Follow these steps to turn on the system for the first time.

- a. Ensure the antenna has a clear, unobstructed view of the sky.
- b. Press the power switch on the rear panel of the TV-Hub to apply power to the TracVision system (see Figure 42).

IMPORTANT!

During startup, the TV-Hub checks the software versions installed in the antenna and updates them if necessary to match the versions it has stored for that model. All three status lights (see Figure 43) will alternate orange while this update is in progress. **Do not turn off the system during this time.** Updates might take up to 40 minutes.

- c. Within a few minutes, the TV-Hub and Power lights should be lit green (the Antenna light will be flashing green).
- d. Plug in and turn on any connected receivers, DVRs, and televisions.

Figure 42: TV-Hub Power Switch

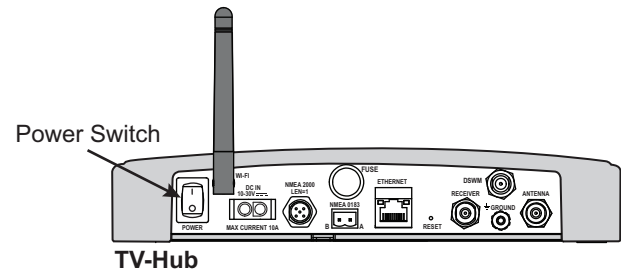
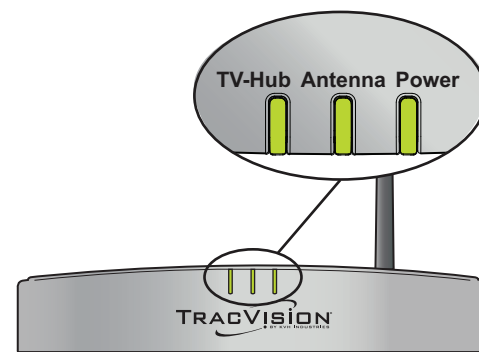

Figure 43: TV-Hub Status Lights



10 Access the Web Interface

Follow the steps for either option below to access the TV-Hub's web interface.

Using the Wireless Connection

- Select the TVHub-<TV-Hub serial number> network from your device's Wi-Fi settings to connect to the TV-Hub (see Figure 44).
- Start your web browser and enter **http://tvhub.kvh**. If the web interface does not appear, try entering **http://172.16.0.1**, which is the default IP address of the TV-Hub.

Using the Ethernet Connection

- Connect a laptop PC configured for DHCP directly to the "Ethernet" port on the TV-Hub (see Figure 45).
- Start your web browser and enter **http://169.254.253.1**.

NOTE: When connected to the vehicle's LAN (see "Connect to an Existing Network" on page 26), you will need to enter the IP Address (dynamic or static) assigned to the TV-Hub. If your laptop has Bonjour[®] installed, you can use it to find the TV-Hub on the network without knowing its IP address.

Figure 44: Wi-Fi Connection

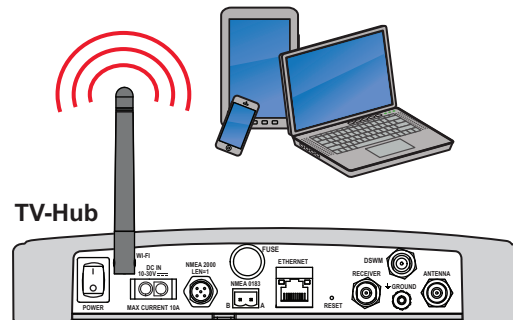
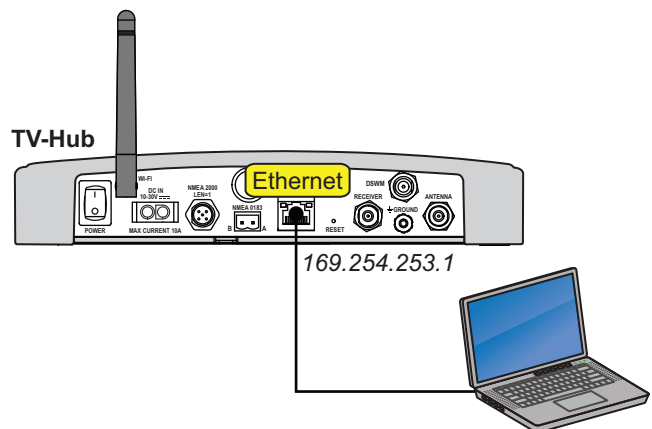

Figure 45: Wired Ethernet Connection



11 Connect to an Existing Network

Optional

Connecting the TV-Hub to a vehicle's local area network (LAN) is required if any of the following conditions apply:

- One or more IP AutoSwitches are installed to enable automatic satellite switching (*DISH Network only*)
- Customer wants to access the TV-Hub's web interface using any device connected to the network (see Figure 46)

NOTE: Connecting the TV-Hub to the vehicle's network using its Wi-Fi rather than an Ethernet cable is not recommended because you lose the ability to connect directly to the TV-Hub's built-in Wi-Fi. You will always need to connect via the network.

NOTE: The Reset button on the rear panel of the TV-Hub (see Figure 47) reverts all network settings back to their original factory settings.

Wired LAN Connection

NOTE: Before connecting via wired LAN, KVH recommends that you set the TV-Hub to **Static mode** and assign a static IP address (see Figure 48). Be sure to choose a static IP address that is outside the router's DHCP range (refer to the router's manual).

- To assign a static IP address, first connect your laptop or mobile device to the TV-Hub (see "[Access the Web Interface](#)" on page 25).
- At the web interface, go to **Settings > Network Settings**. Set the TV-Hub to a static IP address on the onboard network.
- Connect the "Ethernet" port on the TV-Hub to the onboard network (LAN) using the supplied Ethernet cable.

IMPORTANT!

For systems with IP AutoSwitch(es), make sure they are on the same local LAN segment as the TV-Hub (see Appendix A on [page 32](#)).

For DIRECTV systems set up for automatic satellite switching, make sure the receiver(s) have IP addresses in the same subnet as the TV-Hub (see Appendix B on [page 35](#)).

Figure 46: TV-Hub Network Connections

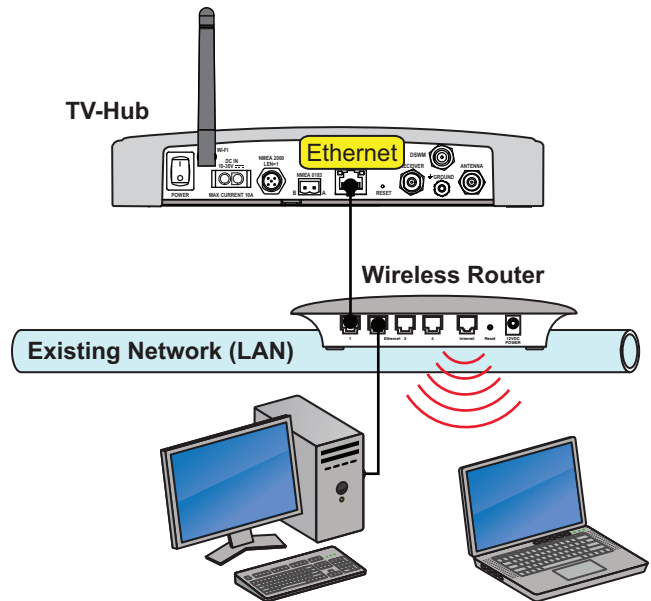

Figure 47: TV-Hub Reset Button

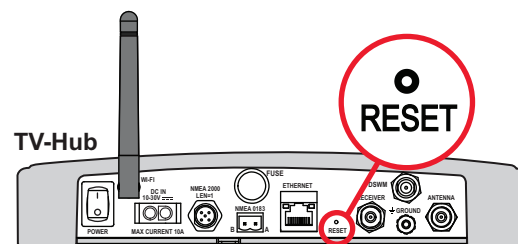

Figure 48: Web Interface Ethernet Settings

Ethernet Settings	
Mode	STATIC
IP Address	172.16.223.92
Subnet	255.255.255.0
Gateway	172.16.223.1
Broadcast	172.16.223.255

12 Secure the Wi-Fi Connection

By default, the TV-Hub's wireless settings are configured for the following:

- Wireless Mode: AP (Access Point)
- SSID: TV-Hub-<TV-Hub serial number>
- IP Address: 172.16.0.1
- Security Mode: Off

KVH strongly advises that you select the **WPA_PSK** security mode as shown in Figure 49 and assign a unique password to prevent unauthorized access to the TV-Hub (at the web interface, go to Settings > Network Settings). If you keep the default settings, you're allowing anyone to access the TV-Hub with their mobile device.

IMPORTANT!

KVH strongly recommends that you keep the TV-Hub set to AP (Access Point) wireless mode. If you select IF (Infrastructure) mode to connect the TV-Hub to your vehicle's network, you will no longer be able to access the TV-Hub's web interface directly.

Figure 49: TV-Hub Security and Password Setting

Wireless Settings	
Wireless Mode	AP (Access Point) ▼
SSID	TVHub-140311659
IP Address	172.16.0.1
Subnet	255.255.255.0
Gateway	172.16.0.1
Broadcast	172.16.0.1
Security Mode	WPA_PSK ▼
Password	240300659

13 Set Up the System

The Setup Wizard appears upon initial startup to step you through system configuration (see Figure 50). Before you begin to set up the system:

- Know the service provider and associated satellite(s)
- Check the latest software version (see below)
- Verify all system components are connected

Update Software and Satellite Library

Before you start the Setup Wizard, update the system software and satellite library to the latest versions. Use the Apple® iOS or Android™ smartphone/tablet mobile app, or follow these steps to use a laptop PC that has the latest update files downloaded to it from the KVH Partner Portal (www.kvh.com/partners).

- Select **Exit** in the Setup Wizard page. The web interface appears.
- At the Updates page of the web interface, select the antenna model. Then select **Install Update** (see Figure 51). Find the **.kvh** file in your downloads folder, then double-click to install.
- Wait for the update to complete. It may take up to 45 minutes. The TV-Hub's lights will alternate orange while the update is in progress. Once complete, the web interface will report that the latest version is installed.
- When the software update is complete, select the Satellite Library. Then select **Install Update**. Find the **.xml** file in your downloads folder, then double-click to install.
- Close the web interface. Then reopen it (see "[Access the Web Interface](#)" on page 25). The Setup Wizard will reappear since setup has yet to be completed.
- Select **Proceed with Setup Wizard**.

Figure 50: Setup Wizard Welcome Page

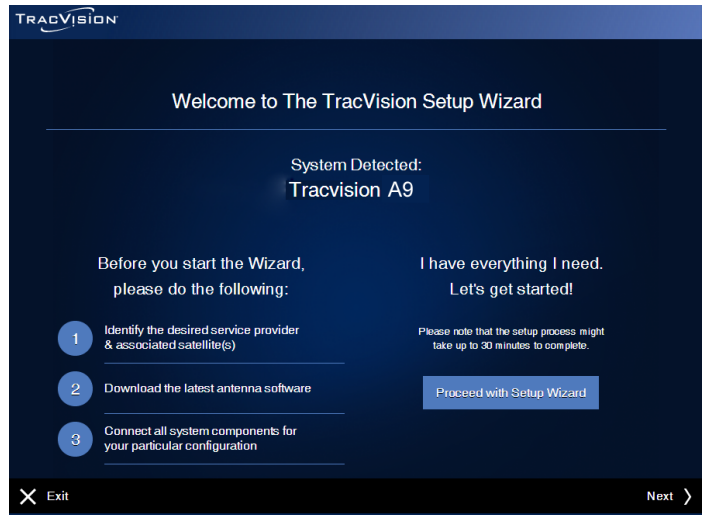
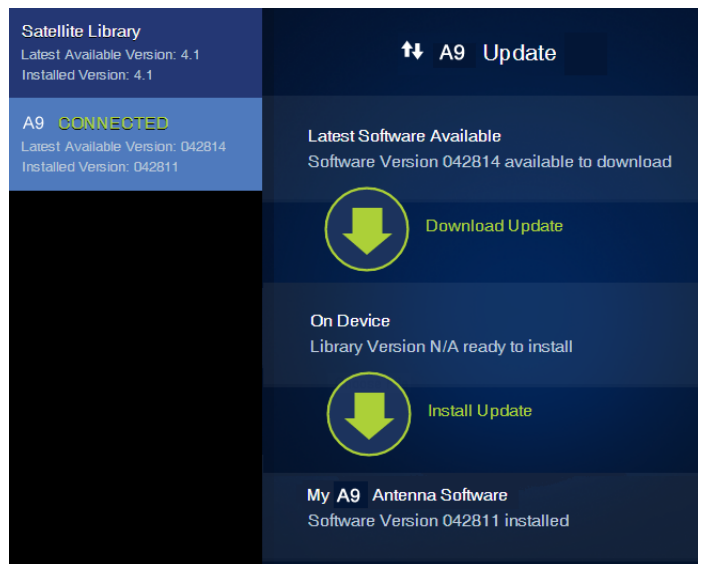

Figure 51: Software Updates Page



13 Continued Set Up the System

Setup Wizard

System configuration continues by prompting you to enter information or perform specific tasks, as necessary. For example:

- Enter installer and vehicle information
- Select a source for GPS position data
- Select the satellite TV service
- Select satellite(s) to track (make your own selections or select one of the preset groups listed in Figure 52), or create user-defined satellites

IMPORTANT!

The antenna cannot see all DISH Network satellites from all locations in the U.S. See www.kvh.com/TVcoverageNA for details.

- Set up automatic switching, if applicable

Additional Setup Information

Once the Setup Wizard has been completed, perform follow-up tasks such as:

- Set up receivers to operate with the system (as instructed by the Wizard)
- Activate the receivers (as instructed by the Wizard)

Figure 52: Compatible Preset Satellite Groups

Service	Satellites (A-B-C-D)
DIRECTV U.S.	DIRECTV Dual: 101W and 119W
DISH Network	Western Arc: 110W, 119W, 129W Eastern Arc: 61W, 72W, 77W Legacy East Arc: 61W, 110W, 119W DISH 500: 110W, 119W 72W: 72W only

NOTE: This list is subject to change. In certain regions of the U.S., the antenna cannot see the 61W, 72W, 77W, 119W, and 129W satellites, due to their low elevation (see www.kvh.com/TVcoverageNA for details).

14 Educate the Customer

Before you leave the vehicle, test the system to ensure the antenna works properly. Fill out the Installation Checklist (*provided in the Welcome Kit*) and return it to KVH. Refer to the instructions on the form.

Give the Welcome Kit to the customer, provide any passwords and static IP addresses you set up, and explain how to use the system. Ensure the customer understands the following.

- How to:
 - Turn on the system
 - Access the web interface
 - Switch satellites (see Figure 53)
 - Select a master receiver (see Figure 54)
 - Interpret TV-Hub status
 - Download software and satellite library updates (using web interface and/or mobile app)
 - Perform general troubleshooting



CAUTION

Make sure the user knows the new height of the vehicle, measured from the road to the top of the antenna, so that he/she can avoid parking garages and overpasses that are too low.

Figure 53: Satellite Switching Selection on Home Page

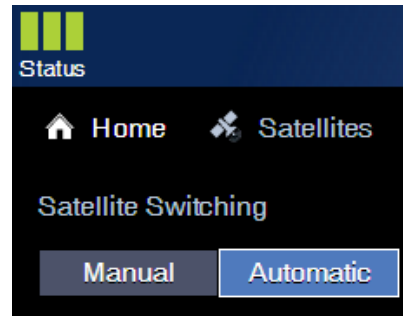
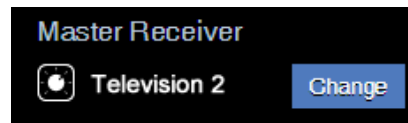

Figure 54: Master Receiver Selection



14 Continued Educate the Customer

- The antenna must have a clear view of the sky to receive satellite TV. Common causes of blockage include trees, buildings, bridges, overpasses, and mountains (see Figure 55). The TracVision system will not work inside a garage. Heavy rain or snow might also temporarily interrupt reception.
- Clean the antenna regularly. Dirt buildup can affect satellite TV reception.
- You must be located within the satellites' coverage area to receive TV signals. Visit www.kvh.com/footprint for coverage maps.
- Please register the system to ensure the best possible service from KVH. Visit www.kvh.com/register for details.

Figure 55: Blockage Example

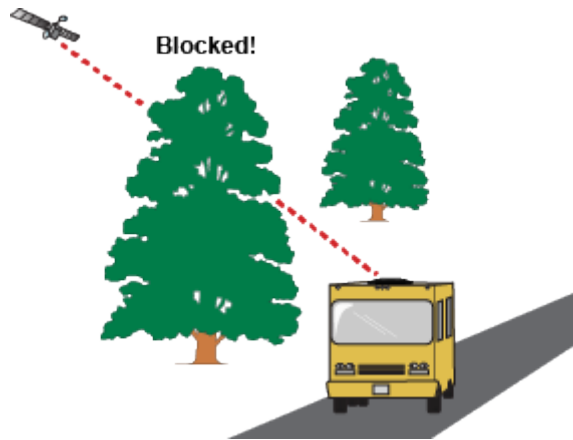

WARNING

If the owner removes the antenna from the roof, then later needs to reinstall it, the owner must apply threadlocker (Loctite 425) to the threads of the mounting screws to avoid a potentially dangerous condition. The mounting screws are prepared with a threadlocking patch that will degrade if the screws are removed. Failure to apply threadlocker to the screws during reinstallation can result in unsecure mounting.



WARNING

It is dangerous to watch TV while driving a vehicle. While the vehicle is in motion, the system is intended for passenger use only.

A Installing an IP AutoSwitch

Follow these steps to add an IP AutoSwitch (KVH part no. 72-0634) to each DISH Network receiver you want to be able to control satellite selection in Automatic satellite switching mode.

NOTE: A receiver connected directly to the TV-Hub's "Receiver" jack can control satellite selection without an IP AutoSwitch.

Inspect Parts

Follow these steps to inspect the kit contents.

- a. Unpack the box and ensure it contains each of the following items:
 - 3 ft (1 m) Ethernet cable
 - 2 ft (60 cm) RF cable
 - Adhesive-backed Velcro strip
- b. Carefully examine all of the supplied parts to ensure nothing was damaged in shipment.
- c. Locate the serial number on the bottom of the IP AutoSwitch (see Figure 57) and record it on the Installation Checklist (*supplied in the Welcome Kit*) for future reference.

Choose a Mounting Location

Choose a mounting location that meets the following requirements:

- Dry, well-ventilated, and away from heat sources
- Provides a clear view of and easy access to the Master Select button (see Figure 57)
- Provides adequate clearance for running the cables and allows for service loops and strain relief
- Within 2 ft (60 cm) of the associated receiver in order to use the supplied cable
- Either a horizontal or vertical surface

Figure 56: IP AutoSwitch



Figure 57: Serial Number and Master Select Button

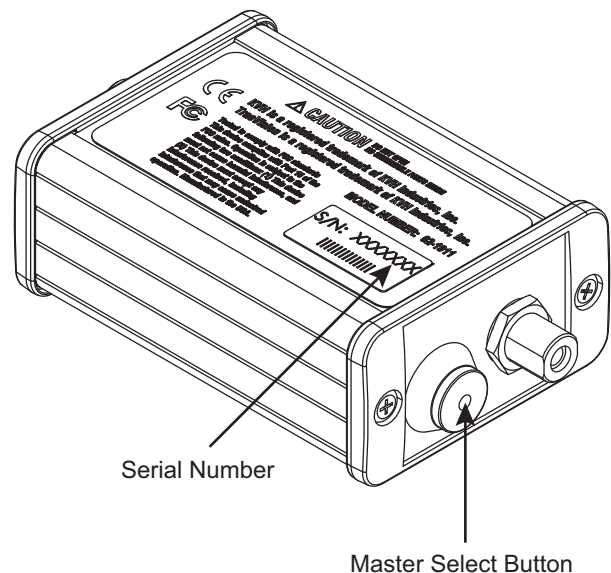

A

Continued Installing an IP AutoSwitch

Configure the IP AutoSwitch

When performing system setup (see “Set Up the System” on page 28), follow these additional steps to configure the IP AutoSwitch.

NOTE: KVH recommends that you run the Setup Wizard in the web interface whenever you change your system’s configuration by adding or removing devices.

- At the AutoSwitch page of the web interface, select **Add IP AutoSwitch** (Figure 59).
- Enter the serial number and choose a friendly name for the IP AutoSwitch (for example, “Television 2”).
- Select **Save** to save your changes.

Select the Master Receiver

Any receiver connected to an IP AutoSwitch can become the master receiver for the system. The master receiver controls satellite selection.

IMPORTANT!

The TV-Hub has a built-in IP AutoSwitch. Any receiver connected directly to the TV-Hub can therefore be selected as a master receiver through the web interface.

- To choose the master receiver, select it on the Home page of the web interface, or press the Master Select button on the associated IP AutoSwitch.
- Verify that the LED in the Master Select button on the IP AutoSwitch is lit green (see Figure 60). The LEDs for any other IP AutoSwitches should be lit orange.

Figure 59: Add IP AutoSwitch Screen

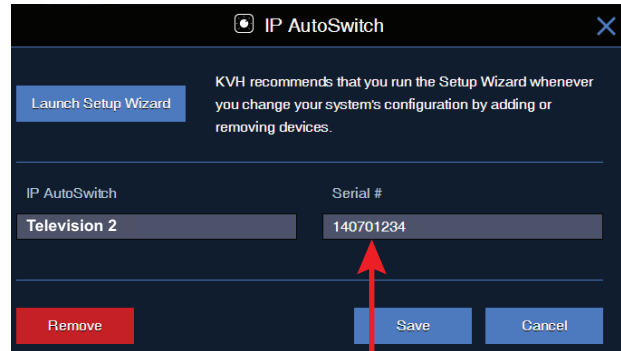

Figure 60: IP AutoSwitch LED Status Indications

LED Color	Indication
Orange	Registered with the system but not currently the master
Orange, flashing	Initializing
Red	Error: <ul style="list-style-type: none"> unable to communicate with the system, network is not detected, or unable to register
Green	Registered with the system and currently the master

B Using a DIRECTV Coax Network

In Automatic satellite switching mode, the TV-Hub can accept commands from the master SWM-compatible DIRECTV receiver to automatically switch between the 101W and 119W satellites. The TV-Hub communicates with the master receiver via the TV-Hub's Ethernet port link to the DIRECTV coax network. Follow the steps in this section to set up this communication link with SWM-compatible receivers

NOTE: The 119W satellite only carries local channels for certain regions of the country. (You can find a list of these regions in the Setup Wizard.) If the customer's locals are carried on DIRECTV's main 101W satellite, there is no need to switch satellites.

DIRECTV Coax Network Connections

DIRECTV uses coax networking technology, by which both satellite TV signals and network communications data are carried by the coax cables. This simplifies installation, since Ethernet cables don't need to be run to all of the receivers.

Install a DECA with power supply, collectively referred to as a DECA Broadband Kit (KVH part no. 72-0859) and formerly called a Cinema Connection Kit. When connected to the SWM splitter and the TV-Hub's Ethernet port, either directly or via an onboard router, the DECA relays messages between the DIRECTV coax network and the Ethernet network (see Figure 61).

Figure 61: DIRECTV Configuration

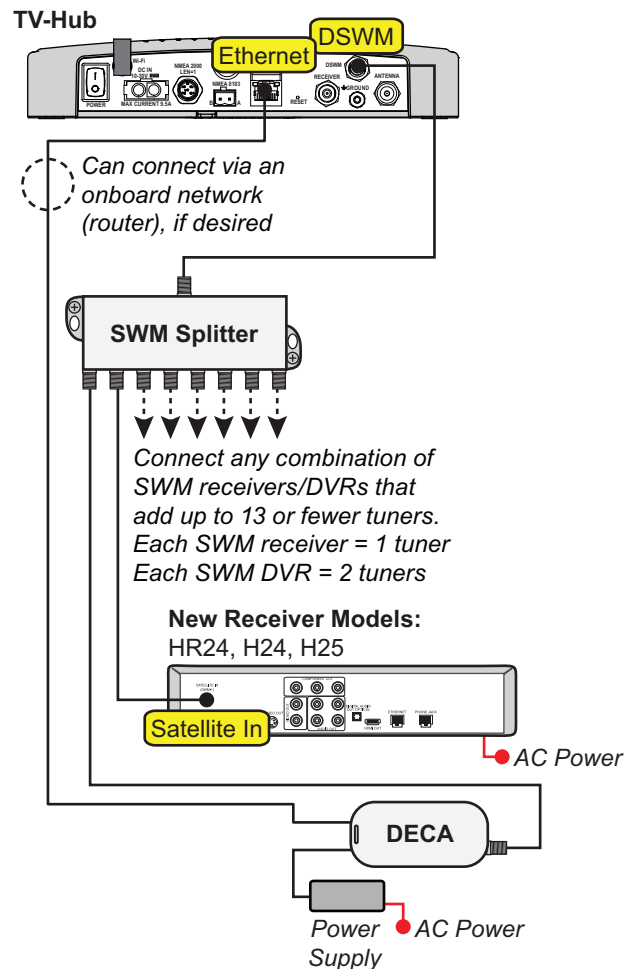

B Continued Using a DIRECTV Coax Network

Additional Equipment for Older Receivers

In addition to the DECA Broadband Kit, you might need to connect an additional device in-line between the receiver and the SWM splitter, depending on the model (see Figure 62).

NOTE: Model HR20-100 requires additional devices not specified here. Contact KVH Technical Support.

H21, H22, H23, HR21, HR22, and HR23

These receivers do not have built-in DECA functionality, but they have an Ethernet port for network connectivity. An additional DECA (KVH part no. 19-1040) is required to support coax networking, supplying the satellite TV signal to the receiver's "Satellite In" port and network communications data to its Ethernet port. (If there are two of each port, use the "Satellite In 1" and "Ethernet 1" ports.)

NOTE: Each DECA you connect directly to a receiver is powered by the receiver. They do not require the separate power supply included in the kit.

H20

This receiver is not network-ready. It is only designed to receive a satellite TV signal via its "Satellite In" port. Since both the satellite TV signal and network communications data are present on the coax cables, a band stop filter (KVH part no. 19-0868) is required to block the network data to prevent potential damage to the receiver. Since the H20 cannot communicate over the network, it cannot control satellite selection.

IMPORTANT!

Be sure to connect all band stop filters before connecting the coax cables.

Figure 62: Additional Equipment for Older Receivers

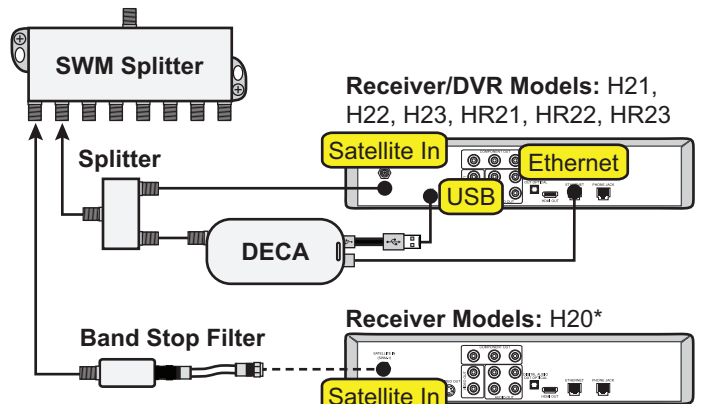

* Model HR20-100 may require additional hardware. Contact KVH Technical Support for details.

B Continued Using a DIRECTV Coax Network

Configuring the DIRECTV Receivers for Automatic Switching

To establish communications between the TracVision system and each SWM-compatible DIRECTV receiver for automatic satellite switching, you need to set each receiver to a static IP address and enter that address, along with the receiver's location, in the TV-Hub's web interface.

Static IP Address Range WITHOUT an Onboard Network

If the DECA Broadband Kit is connected directly to the TV-Hub's "Ethernet" port (no router is installed), set each receiver's IP address to any address ranging from 192.168.x.2 to 192.168.x.149, where x=1<the last 2 digits in the TV-Hub's serial number>.

For example, if the serial number of the TV-Hub is 140901484, you might assign an IP address of 192.168.184.2 (see Figure 63). Refer to the instructions in ["Assigning Static IP Addresses to DIRECTV Receivers"](#) on page 38. The TV-Hub has a hidden IP address of 192.168.x.1 reserved for automatic switching communications. This IP address is not shown on the Network Settings page of the web interface.

Static IP Address Range WITH an Onboard Network

If the TV-Hub and the DECA Broadband Kit are connected to an onboard network (i.e., router), set each receiver to a static IP address that is outside the router's DHCP range (see Figure 64). (Refer to the router's user manual for details on finding its IP address range.) For example, if the router has an IP address of 192.168.1.1 and assigns IP addresses ranging from 192.168.1.100 to 192.168.1.149 via DHCP, you could set each receiver's IP address to any address ranging from 192.168.1.150 to 192.168.1.254. Refer to the instructions in ["Assigning Static IP Addresses to DIRECTV Receivers"](#) on page 38.

Figure 63: IP Addressing for Automatic Switching (Example)

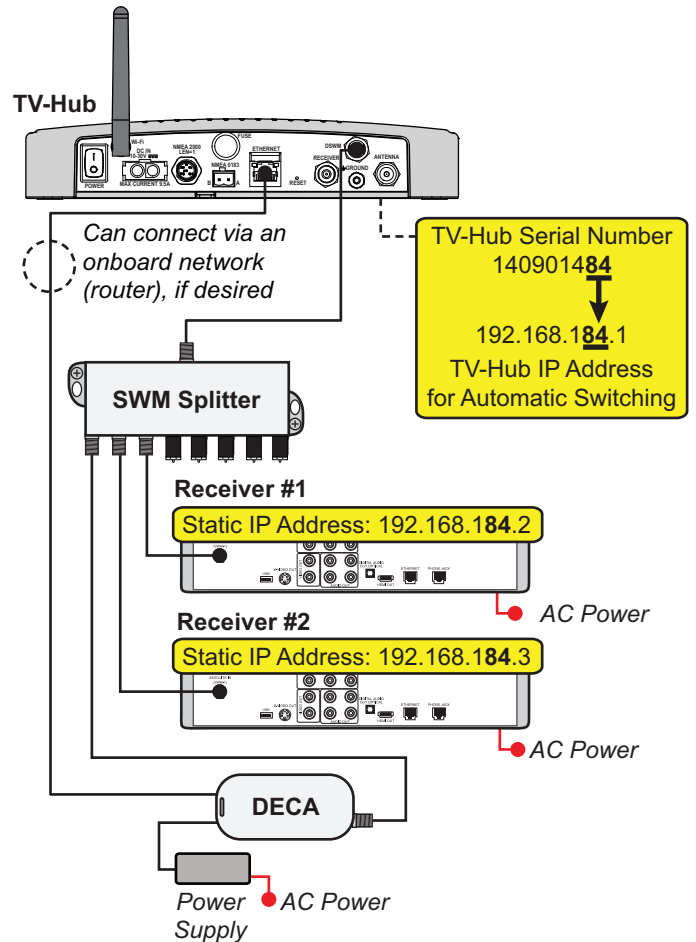

Figure 64: Router DHCP Settings (Example)

IP Address:	192 . 168 . 1 . 1
Subnet Mask:	255.255.255.0
Router Name :	Cisco76205
DHCP Server:	<input checked="" type="radio"/> Enabled <input type="radio"/> Disabled <input type="button" value="DHCP Reser"/>
Start IP Address:	192 . 168 . 1 . 100
Maximum Number of Users:	50
IP Address Range:	192 . 168 . 1 . 100 to 149
Client Lease Time:	0 minutes (0 means one day)

B Continued Using a DIRECTV Coax Network

Assigning Static IP Addresses to DIRECTV Receivers

Once you have identified a valid static IP address range for the receivers, follow these steps to assign a unique static IP address within that range to each receiver.

NOTE: These steps may vary, depending on the receiver's model and software version. Refer to the receiver's owner's manual for details.

1. Press **MENU** on the receiver's remote control to access the onscreen menu.
2. At the main menu, highlight **Settings & Help**. Then select **Settings**.
3. Highlight and select **Internet Setup**.
4. Select **Advanced Setup**.
5. Highlight and select **Advanced IP Config**.
6. Change the IP address to the new static IP address (see Figure 65).
7. **WITHOUT an Onboard Network** Enter "255.255.255.0" for the subnet mask, and enter the TV-Hub's IP address for default gateway and DNS.

WITH an Onboard Network

Enter the router's subnet mask, and enter the router's IP address for default gateway and DNS.

8. Highlight and select **Connect Now** to save your changes. Disregard any error messages about missing Internet connectivity. Note this receiver's IP address and location onboard for future reference.
9. Repeat this procedure for each additional receiver. Be careful not to use the same IP address twice.

Figure 65: IP Address on a DIRECTV Receiver (Example)

WITHOUT an Onboard Network (No Router)

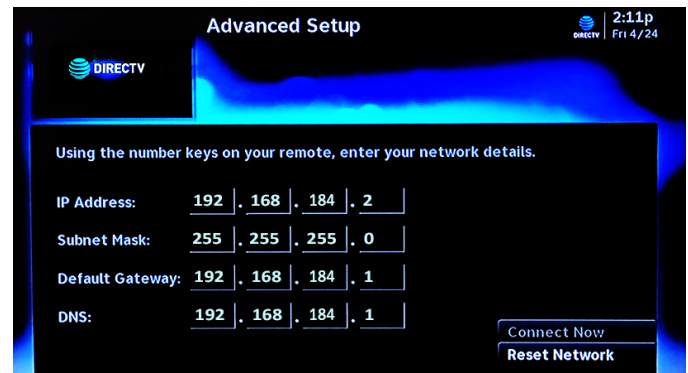

WITH an Onboard Network (Using a Router)

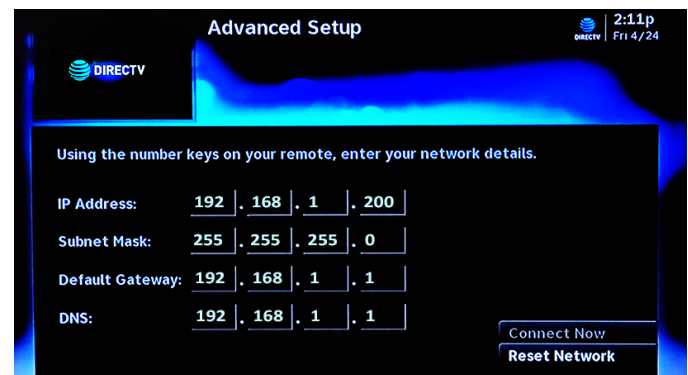

B Continued Using a DIRECTV Coax Network

10. Add the new receivers to the Autoswitch page of the web interface. Enter each receiver's static IP address and assign it a friendly name (e.g., "Salon") (see Figure 66).

IMPORTANT!

Be sure to enable external device access, as directed by the TV-Hub's Setup Wizard. If the TV-Hub is then unable to communicate with the receiver, try resetting the receiver (press its red reset button or unplug it, wait 15 seconds, then plug it back in and turn it on).

Figure 66: Adding a DIRECTV Receiver to the Autoswitch Page

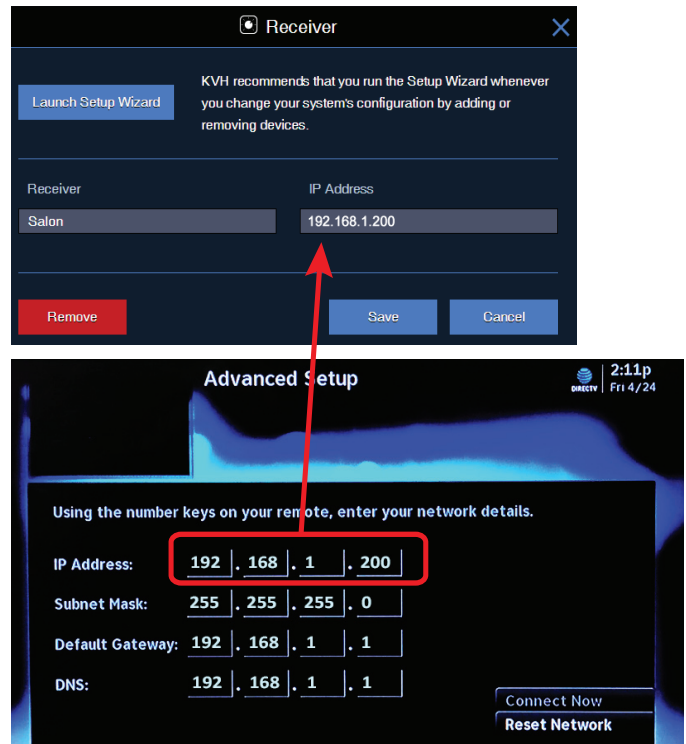



www.kvh.com



KVH Industries A/S
EMEA Headquarters
Kokkedal, Denmark
Tel: +45 45 160 180 Fax: +45 45 160 181
E-mail: info@emea.kvh.com

KVH Industries, Inc.
World Headquarters
Bristol, RI U.S.A.
Tel: +1 401 847 3327 Fax: +1 401 849 0045
E-mail: info@kvh.com

KVH Industries Pte Ltd.
Asia-Pacific Headquarters
Singapore
Tel: +65 6513 0290 Fax: +65 6472 3469
E-mail: info@apac.kvh.com