

KVH Industries, Inc.

TracPhone® V7HTS
in 32" (81 cm) Dome
(to match TracVision® TV8)



Installation Guide

PLEASE READ!

Important Addendum to the Installation Guide

New RG-11 Cable Connectors

The Belden Snap N Seal connectors (SNS11AS), used to terminate RG-11 RF cables as described in your antenna installation manual, are no longer available. KVH has validated the PPC Belden-brand EX[®] series 11 universal compression cable connectors as a suitable replacement (see Figure 1).

IMPORTANT!

The EX series 11 universal connectors differ slightly from the Snap N Seal connectors, so it is critical that you follow the installation instructions provided at the manufacturer's website and watch the short video demonstration: <https://www.ppc-online.com/ex-series-7-11-compression-connectors>.

Be sure to adhere to the following steps, in particular:

1. After folding back your cable's braid, align the center conductor with the grooves on the new connector's body. Then mark the cable where it aligns with the base of the connector (see Figure 2).
2. Insert the cable into the connector. Then push firmly, while rotating clockwise, until the connector reaches the mark you made in step 1. The center conductor should protrude from the connector nut.

New RG-11 Compression Tool

Prepare your cables with the tools provided in the RG-11 crimp tool kit (KVH part no. 72-0493) to ensure that the cables are stripped to the correct length for proper engagement between the cable and connector (see Figure 3). Use the Belden CST596711 cable stripper tool (KVH part no. 19-0719) to prepare your cables, then compress the connectors with the new VT200 compression tool (KVH part no. 19-1141-0200) (see Figure 4). When compression is complete, the center conductor should be rigid. If the pin can move in or out, cable performance may be degraded.

Figure 1: New EX Series 11 Connectors for RG-11



KVH Part No. 23-0917

Figure 2: Align the Cable With the Connector

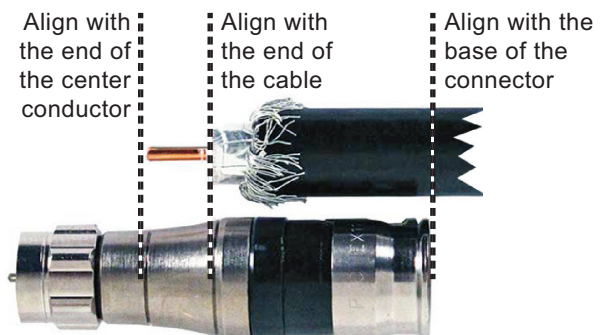

Figure 3: Cable Strip Lengths

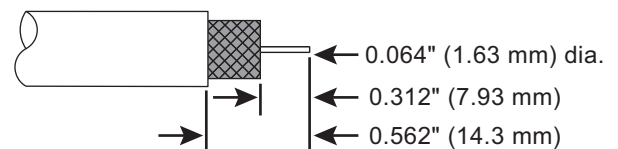

Figure 4: New Compression Tool



Updated LMR-600 Connectors

The Times Microwave EZ-600-FMH-75 connectors, used to terminate LMR-600 cables as described in your antenna installation manual, have been replaced with the new functionally identical EZ-600-FM-75 connectors. The new connector version no longer requires that you trim the braid prior to securing the ferrule. Simply slide the ferrule over the braid, as you would have previously, to crimp the braid beneath the ferrule (see Figure 5).

Figure 5: New LMR-600-FM-75 “No Trim” Connector

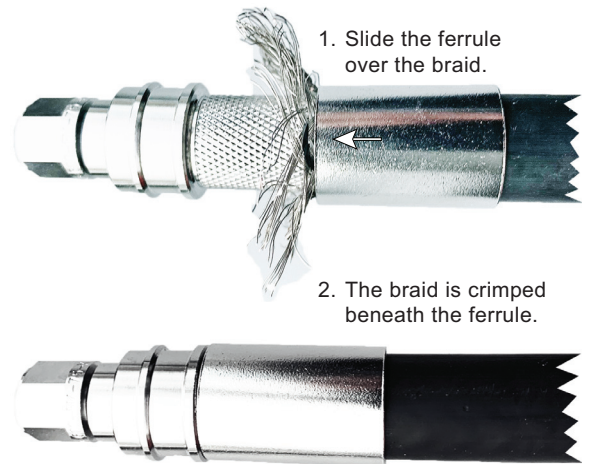



PLEASE READ!

Important Addendum to the Installation Guide

Single Wi-Fi Antenna on ICM/ACU

The system's ICM/ACU now requires just a single Wi-Fi antenna. Connect the supplied Wi-Fi antenna to the Wi-Fi connector located next to the input power connector on the rear panel as shown here. The other Wi-Fi connector is no longer used.

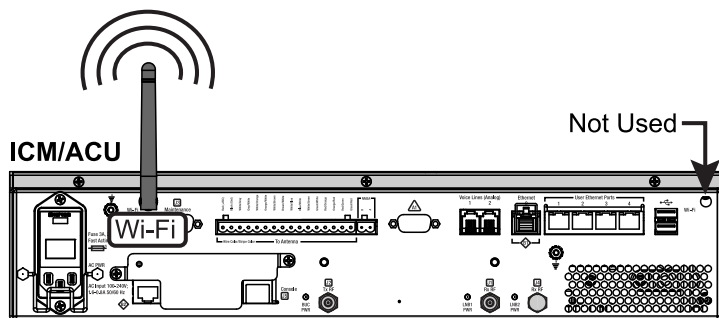

NOTE: The new Wi-Fi module built into the ICM/ACU will provide the same performance with a single Wi-Fi antenna that two antennas provided with the previous version.

Please Read

Important Addendum to Installation Guide



New MTA Model for Adding KVH VoIP Lines

KVH is no longer selling the MTA model shown in the installation documentation (KVH part no. 19-0504), as it has been discontinued by the manufacturer. KVH is now selling a new, upgraded MTA model (KVH part no. 19-1191) (see Figure 1) as a drop-in replacement for the old model.

When connecting the new MTA model to the KVH below decks unit (BDU), refer to Figure 2 for an updated wiring diagram.

Figure 1: New MTA Model



Figure 2: New MTA Wiring Diagram

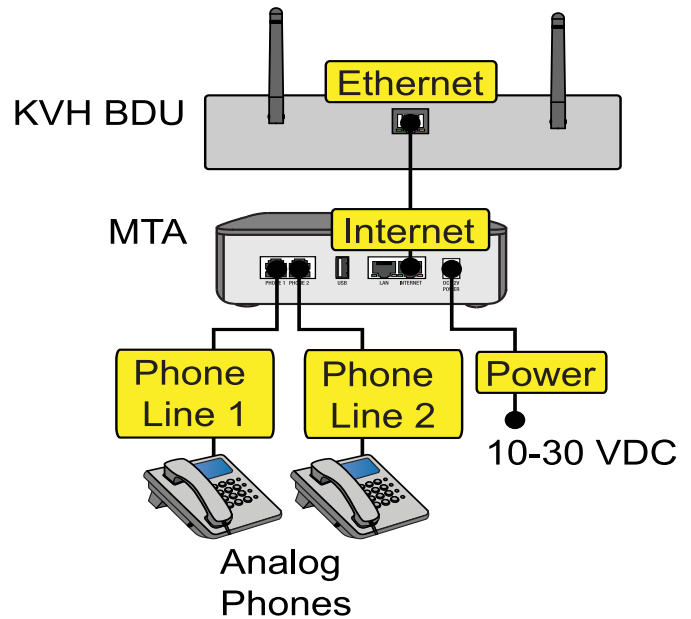

TracPhone V7-HTS in 32" (81 cm) Dome Installation Guide

mini-VSAT BroadbandSM System with Integrated CommBoxTM Modem

This guide explains how to install the TracPhone V7-HTS mini-VSAT Broadband satellite communications system. Operation instructions are provided in the Quick Start Guide.

Installation Steps

1. Inspect Parts and Get Tools	3	12. Wire the ICM.....	20
2. Plan the Antenna Installation	4	13. Connect Power.....	23
3. Plan the ICM Installation.....	6	14. Turn On the System	25
4. Prepare the ICM.....	7	15. Update the System Software.....	26
5. Mount the ICM	8	16. Customize the Web Interface.....	27
6. Prepare the Antenna Site.....	9	17. Set Up No-Transmit Zones	28
7. Remove the Shipping Restraints	10	18. Commission the Modem	30
8. Prepare the Antenna Cables	11	19. Test the System	31
9. Wire the Antenna	14	20. Configure the Network	32
10. Mount the Antenna	17	21. Connect Voice Line Equipment.....	38
11. Prepare the Power/Data Cable	18	22. Educate the Customer.....	39

CAUTION - RF Radiation Hazard



The antenna transmits radio frequency (RF) energy that is potentially harmful. Whenever the system is powered on, make sure everyone stays more than 36 feet (11 m) away from the antenna. As shown in the illustration, no hazard exists directly below the antenna.

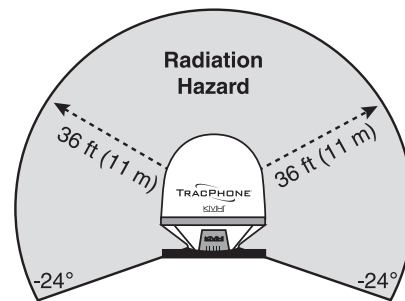

Who Should Install the System?

To ensure a safe and effective installation, only a KVH-certified technician should install the TracPhone system. To find a technician near you, visit www.kvh.com/wheretogetservice.

Technical Support

North/South America, Australasia:

Phone: 1 866 701-7103 (*U.S. only*)

Phone: +1 401 851-3806

Email: mvbsupport@kvh.com

Europe, Middle East, Africa, Asia-Pacific:

Phone: +45 45 160 180

Email: mvbsupport@kvh.com

Important Safety Information



This icon indicates a danger, warning, or caution notice. Be sure to read these carefully to avoid injury.



WARNING

Risk of Electric Shock

Potentially lethal voltages are present within the ICM when it is connected to AC power. To avoid electric shock, do not open the chassis enclosure. There are no user-serviceable parts inside.



WARNING

Risk of Electric Shock

If any component of the TracPhone system becomes damaged and/or no longer functions normally, disconnect it from vessel power, secure it from unintended operation, and contact KVH Technical Support (see “Technical Support” on page 1). All repairs or modifications must be performed by a trained, KVH-certified technician. If you are a KVH-certified technician, you still must contact KVH Technical Support prior to conducting any repairs or modifications to the equipment.



WARNING

Risk of Explosion

Do not operate the ICM (or any other electrical device) in an environment where flammable gases, vapors, or dusts are present. In addition, do not operate the ICM in an environment with a temperature outside its 5° F to 131° F (-15° C to 55° C) temperature range.



WARNING

Risk of Electric Shock

Failure to ground the TracPhone system properly to ship’s ground will cause an unsafe floating ground condition, risking potentially lethal electric shock. See “Connect Power” on page 23 for details on the proper grounding of the equipment.



CAUTION

RF Radiation Hazard

The antenna transmits up to 4 watts of radio frequency (RF) energy that is potentially harmful. Whenever the system is powered on, make sure everyone stays more than 36 feet (11 m) away from the antenna. No hazard exists directly below the antenna. See illustration on page 1.

1 Inspect Parts and Get Tools

Before you begin, follow these steps to make sure you have everything you need to complete the installation.

- a. Unpack the box and ensure it contains everything shown in Figure 1 and on the *Kitpack Contents List*. Save the packaging for future use.

IMPORTANT!

Always lift the antenna by the baseplate and never by the radome or any portion of the internal antenna assembly (see Figure 1).

- b. Carefully examine all of the supplied parts to ensure nothing was damaged in shipment.
- c. Gather all of the following tools and materials that you will need:
 - Flat-head and Phillips-head screwdrivers
 - Electric drill and 1/2" (13 mm) bit
 - 2" (51 mm) hole saw
 - 5/16" hex driver
 - 7/8" and 17 mm socket wrenches
 - 7/16" open-end torque wrench set to 20 in.-lbs
 - 17 mm socket torque wrench set to 21 ft.-lbs
 - Light hammer and center punch
 - Adhesive tape
 - Silicone sealant, self-vulcanizing tape, or equivalent
 - Heat gun (for heat shrink)
 - Eye protection
 - Shop towels
 - Voltmeter
 - Utility knife
 - Flush cutters
 - Needle-nose pliers

Figure 1: TracPhone V7-HTS System Components

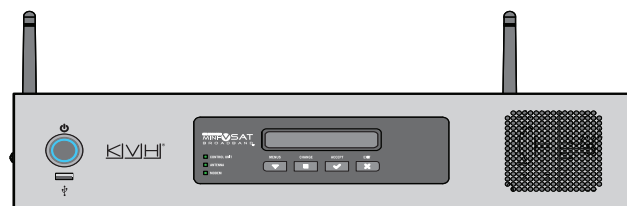
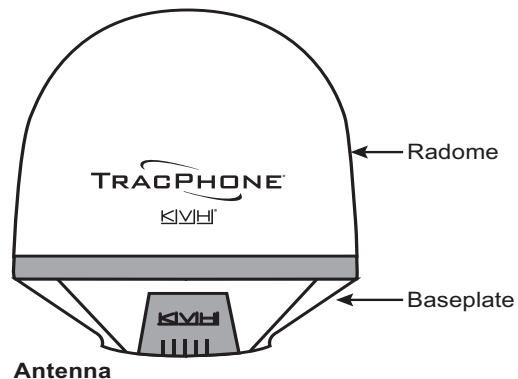

- Wire stripper/terminal crimper
- File
- Two 75Ω RF coax cables, "F" connectors, and associated termination tools (see page 11)
- NMEA 0183 talker and interface cable (see page 21)
- Isolation transformer, if required (see page 23)
- Laptop PC with the latest TracPhone V7-HTS ICM/antenna software downloaded from the KVH Partner Portal (www.kvh.com/partners)

2 Plan the Antenna Installation

Before you begin, consider the following antenna installation guidelines.

Choose a Suitable Location

- Select a location that is as close as possible to the intersection of the vessel's centerline and midships.
- Temperature must be within the operating range (-30°C to 55°C (-22°F to 131°F)).
- Avoid placing the antenna near any magnetic compasses or other onboard antennas to prevent potential interference.
- Make sure the mounting surface is wide enough to accommodate the antenna's base (see Figure 2). Also make sure it is flat, level (within $\pm 2^\circ$), strong enough to support the antenna's weight, and rigid enough to prevent antenna vibration.

Prevent RF Radiation Exposure

Select a location that is well above any areas accessible to passengers and crew to reduce the risk of RF radiation exposure. (See page 1 for an illustration of the hazard area.)

If mounting the antenna near an accessible area is unavoidable, you may configure one or two no-transmit zones to prevent transmissions in hazardous directions. (See "Set Up No-Transmit Zones" on page 28 for details.)

Figure 2: Antenna Dimensions

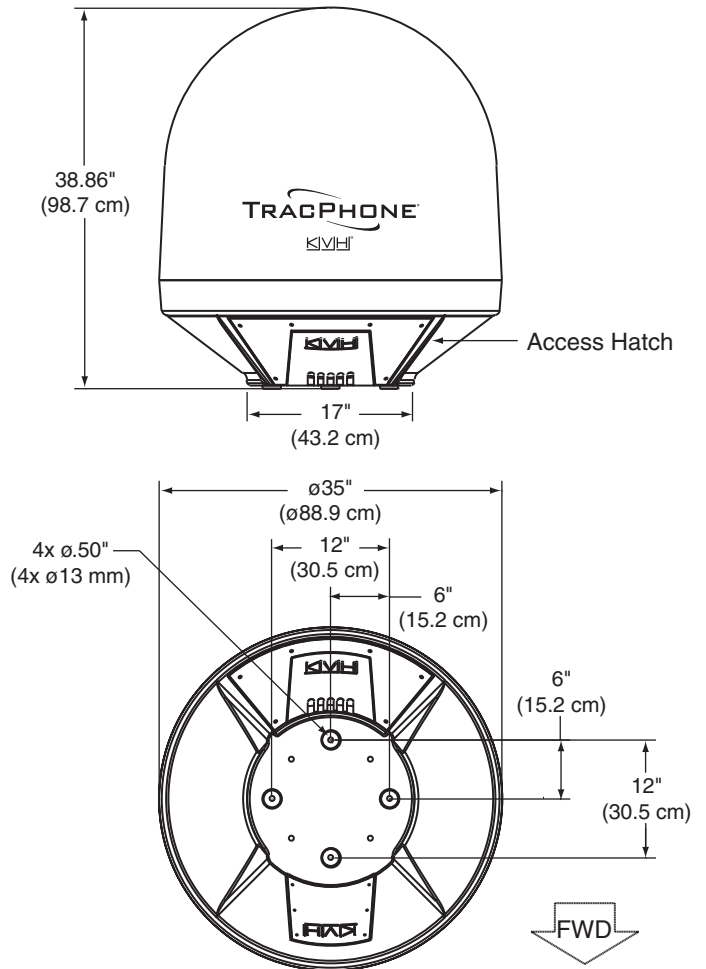

2 Continued Plan the Antenna Installation

Minimize Satellite Blockage

The antenna requires a clear view of the sky to transmit and receive satellite signals (see Figure 3). The fewer obstructions, the better the system will perform.

Avoid RF Interference

Although many variables determine the exact distance required between the antenna and radar/high-power radio transmitters, including transmitter beam properties and the reflective properties of nearby surfaces, consider the following general guidelines when selecting a safe antenna location:

IMPORTANT!

RF emissions from radars and high-power radio transmitters may damage the antenna or impair its performance if it's improperly positioned within the beam path.

- Mount the antenna as far away as possible from the radar and high-power radio transmitters.
- Do not mount the antenna at the same level as the radar. Most radar transmitters emit RF energy within an elevation range of -15° to $+15^{\circ}$ (see Figure 4). Therefore, mount the antenna outside this elevation range and at least 10 ft (3 m) away from the transmitter.

IMPORTANT!

Never place the antenna in the beam path of the radar regardless of distance. Radar energy may damage the antenna.

Figure 3: Blockage from Obstruction

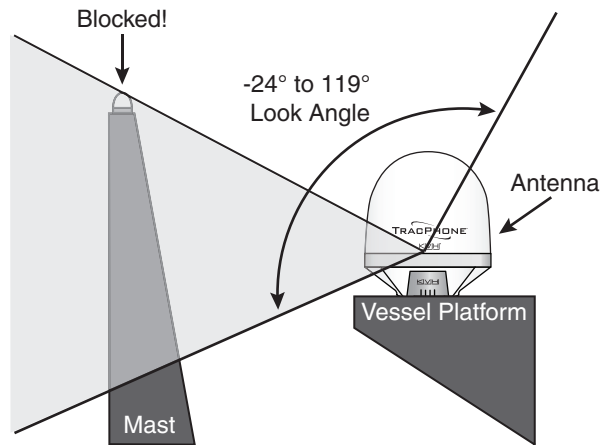
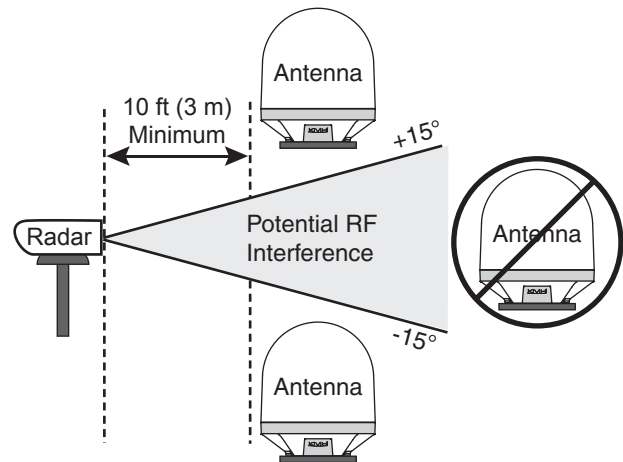

Figure 4: Avoiding RF Interference



3 Plan the ICM Installation

Before you begin, consider the following installation guidelines for the ICM.

- Select a mounting location in a dry, well-ventilated area belowdecks away from any heat sources or salt spray.
- Temperature must be within the operating range (-15°C to 55°C (5°F to 131°F)).
- Be sure the front panel will be easily accessible to the user.
- Leave enough room at the rear panel to accommodate the connecting cables.
- To use the supplied power/data cable, the ICM must be located within 100 ft (30 m) of the antenna. However, you can order a longer cable run if necessary.
- Be sure the location provides adequate Wi-Fi reception. Do not install it in an area surrounded by metal or near any electrical devices that emit RF noise.

Figure 5: ICM Dimensions

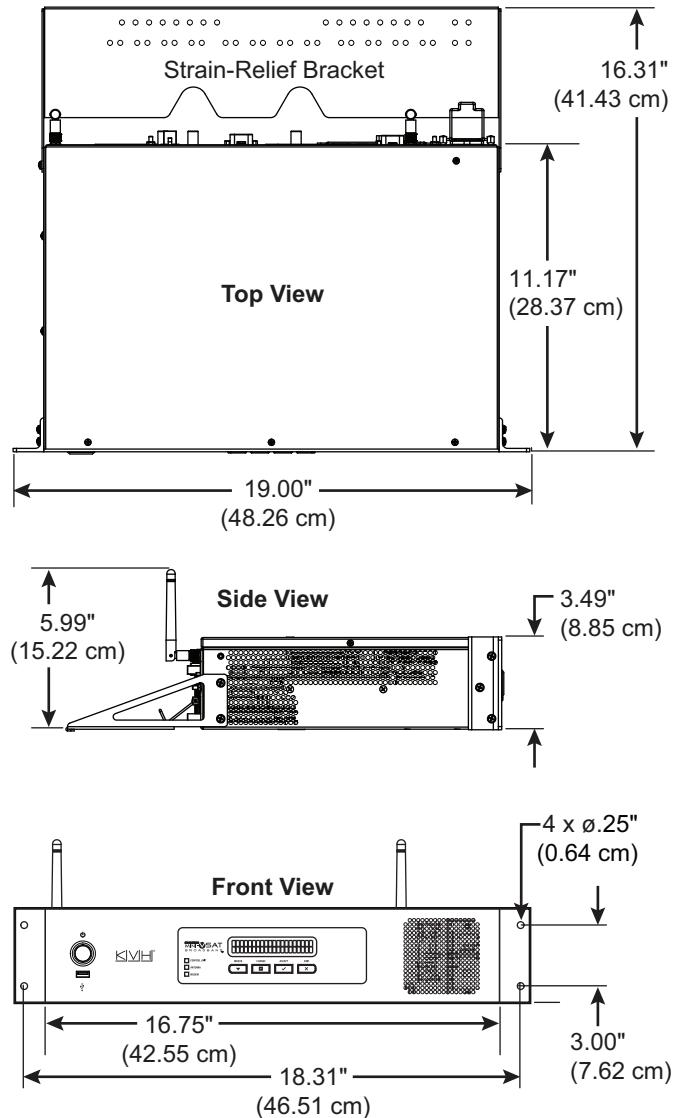

4 Prepare the ICM

Follow these steps to prepare the ICM for installation.

Connect the ICM Jumper Cable

Connect the supplied straight-through Ethernet jumper cable from the “B1” jack to the “B2” jack on the rear panel of the ICM (see Figure 6).

Attach the Wi-Fi Antennas

Connect the two supplied Wi-Fi antennas to the rear panel of the ICM (see Figure 6).

Figure 6: Jumper Cable and Wi-Fi Antenna Connection

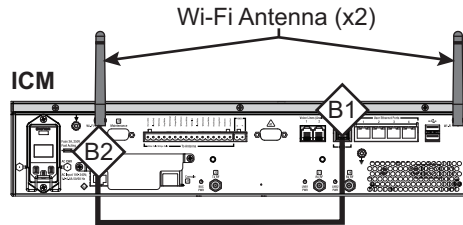

5 Mount the ICM

There are two options for mounting the ICM:

Option 1 - Inside an equipment rack

Option 2 - To a horizontal surface

NOTE: You may choose to wait to mount the ICM until after you have completed all system wiring.

Option 1 – Rack Mount

The ICM is sized to fit a standard 19" (48.26 cm) rack, occupying 2U of space. Follow these steps to secure the ICM in an equipment rack.

- Attach the supplied strain-relief bracket to the back of the ICM using four supplied #6-32 screws and washers (see Figure 7).
- Insert the ICM into the rack and secure its front mounting brackets to the rack using four M6 screws and washers (see Figure 8).

Option 2 – Horizontal Surface Mount

Follow these steps to mount the ICM to a horizontal surface.

- Remove the six #6-32 screws and washers securing the two rack-mount brackets to the front of the ICM (see Figure 9). Remove the brackets.
- Attach the supplied strain-relief bracket to the back of the ICM, and attach the supplied "L" mounting brackets to the sides of the ICM, using six supplied #6-32 screws and washers (see Figure 10).
- Mount the ICM to the vessel using fasteners appropriate for the mounting surface.

Figure 7: Attaching the Strain-Relief Bracket

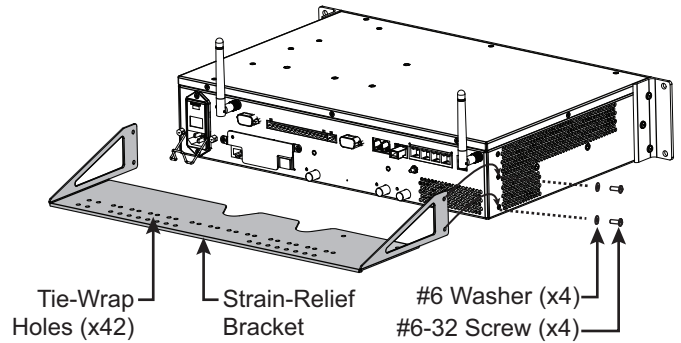

Figure 8: Securing the ICM in the Rack

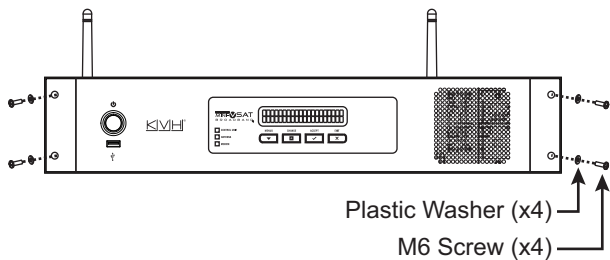

Figure 9: Removing the Rack-Mount Brackets

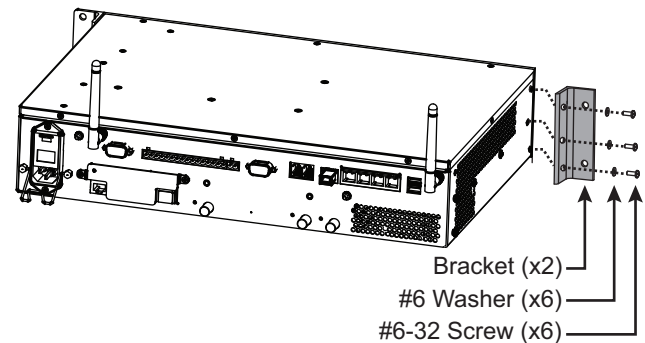
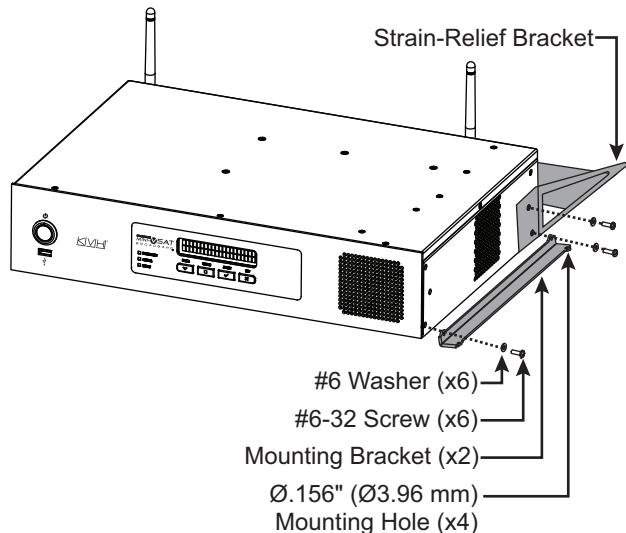

Figure 10: Attaching the Mounting and Strain-Relief Brackets



6 Prepare the Antenna Site

Once you have identified a suitable antenna mounting site, according to the guidelines provided in Step 2 on page 4, follow these steps to drill the mounting holes and cable access hole to prepare the site for installation.

- a. Unfold the antenna mounting template (supplied in the Customer Welcome Kit) and place it onto the mounting surface. Make sure the “FWD” (forward) arrow points toward the bow and is parallel to the vessel’s centerline (see Figure 11).

NOTE: You don’t need to mount the antenna exactly on the vessel’s centerline, but the antenna’s forward arrow must be parallel to it.

- b. Using a light hammer and center punch, mark the locations for the four mounting holes and cable access hole on the mounting surface in the locations indicated on the template.
- c. Drill a 1/2" (13 mm) hole at the four mounting hole locations you marked in Step b. Later, you will insert four M10 bolts through these holes **from below** to secure the antenna to the mounting surface.
- d. Cut out the 2" (51 mm) cable access hole in the location you marked in Step b. Smooth the edges of the hole to protect the cables. Later, you will route the power/data and RF cables through this hole and into the vessel. (You may also apply anti-chafe material around the cables to protect them from abrasion.)
- e. Clean and dry the antenna mounting surface.
- f. Peel off the paper backing from the supplied foam seal to expose the adhesive. Then press the foam seal down firmly onto the mounting surface, ensuring the hole in the foam seal aligns with the cable access hole in the mounting surface (see Figure 11).

NOTE: Apply the foam seal to the vessel mounting surface, not to the antenna’s baseplate. You will have difficulty connecting the cables to the antenna if the foam seal is attached to the baseplate.

Figure 11: Antenna Mounting Holes Layout

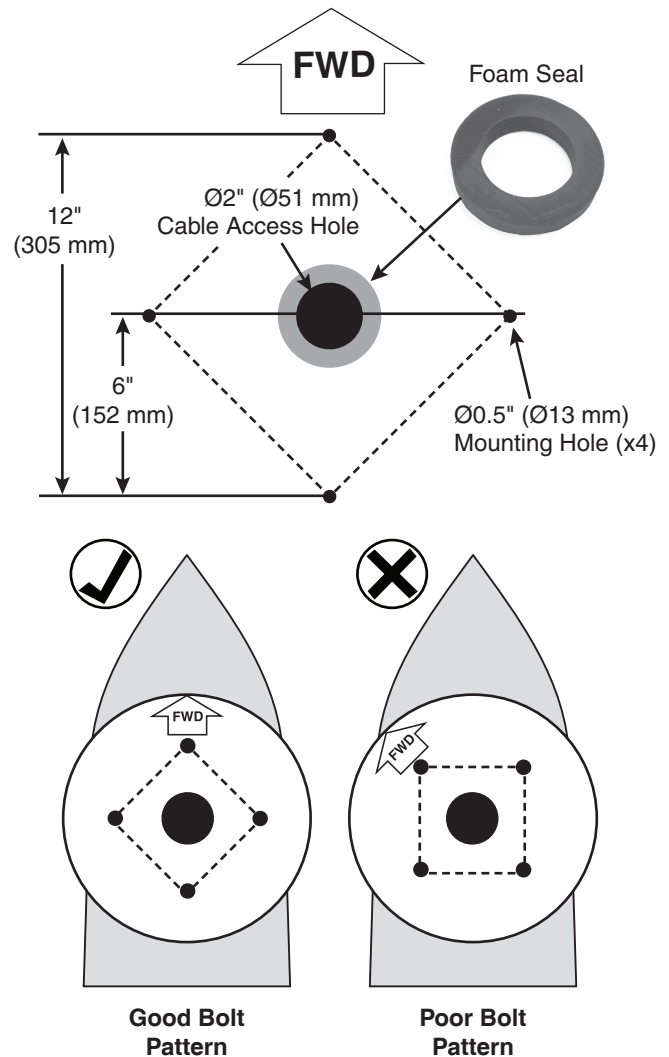

7 Remove the Shipping Restraints

Inside the antenna, a foam shipping restraint prevents the antenna assembly from moving during shipment. Follow these steps to remove these restraints.

- a. Remove the eight #10-32 screws securing the radome to the baseplate (see Figure 12). Carefully lift the radome straight up until clear of the antenna assembly and set it aside in a safe place. If you keep the radome topside, secure it with a lanyard to prevent it from falling overboard.
- b. Carefully cut and remove the tie-wrap securing the foam shipping restraint that is wedged underneath the reflector (see Figure 12). Save this restraint for future use.

IMPORTANT!

Once you have removed the foam restraint, handle the antenna carefully, as its internal assembly will rotate freely. If the antenna assembly hits a mechanical stop with excessive force, the limit switch might become damaged.

- c. Remove the four 3/8"-16 bolts securing the antenna to the shipping pallet (see Figure 12).
- d. Transport the antenna to the mounting location.

NOTE: The two hoisting eyelets on the antenna frame may be used to lift the antenna, if necessary (see Figure 13). After they have been used once, make sure they are undamaged and free of cracks before using them again.

Figure 12: Location of Radome Screws and Restraint Bolts

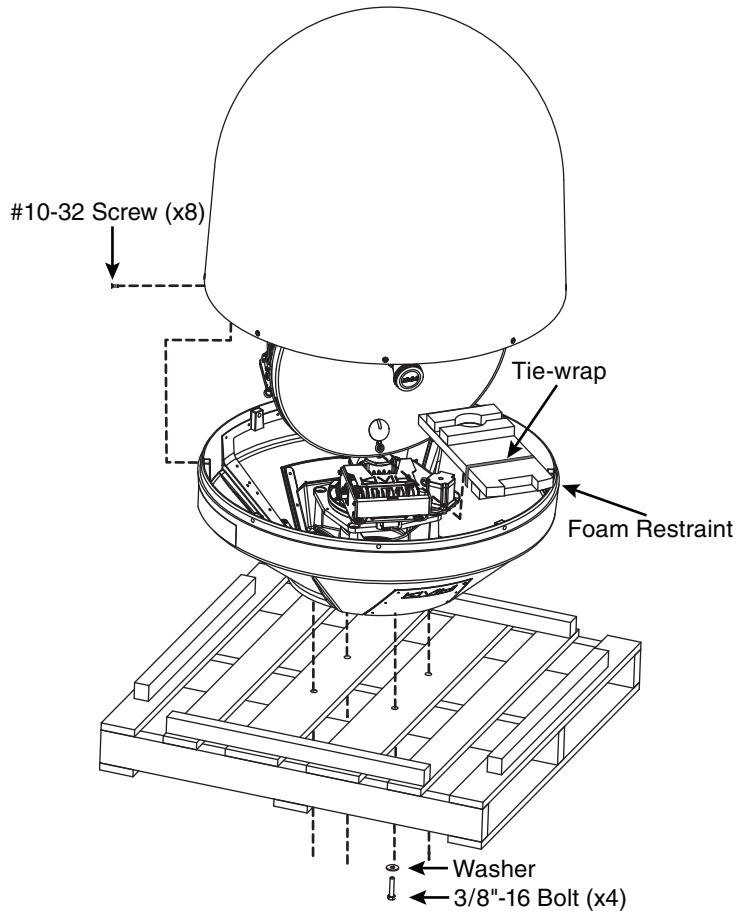
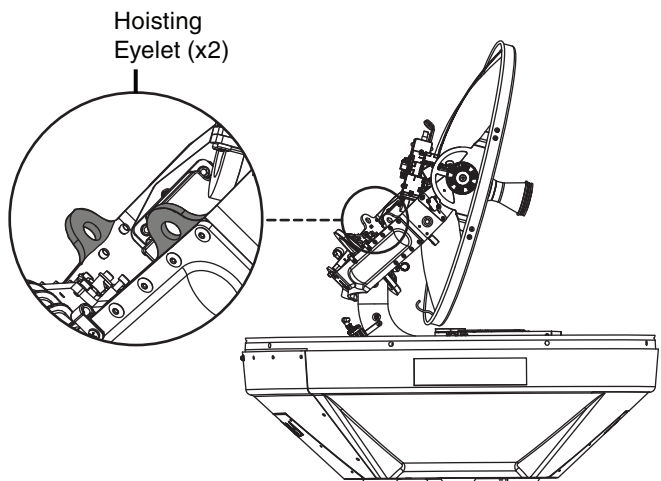

Figure 13: Antenna Hoisting Eyelets



8 Prepare the Antenna Cables

Follow these steps to prepare and route the RF and power/data cables.

Prepare the Customer's RF Cables

You need to connect two 75Ω RF coax cables from the antenna location to the ICM. Refer to Figure 14 to determine the type of cables and connectors required for your cable run. Then prepare both of them as described below.

IMPORTANT!

- If you use RG-11 RF cables 80-100 ft (25-30 m) in length, you can avoid the modem commissioning step. See "Commission the Modem" on page 30.
- RF cables must be rated for 75Ω, not 50Ω.
- Low-quality, poorly terminated, or improperly installed RF cables are the most common cause of system problems. Terminate all RF cables with high-quality "F" connectors using the proper stripping/crimping tools, exactly to the manufacturer's specifications. See page 46 for instructions on terminating LMR cables.
- Do not use RG-6 cable, as it will damage the system. Use of any cables not specified in Figure 14 will void the warranty.
- Make sure the center conductor pin at each end of the finished cables is free of burrs and 1/4" (0.20"-0.28") (5-7 mm) in length, measured from inside the nut to the tip, to ensure proper engagement.
- (LMR cables only) Make sure there is no gap between the end of the cable jacket and the start of the connector.
- When determining cable lengths, don't forget to account for service loops, 14" (35 cm) in diameter, at each end.

Figure 14: RF Cable Options

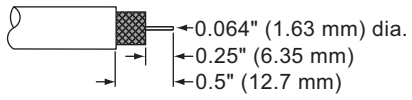
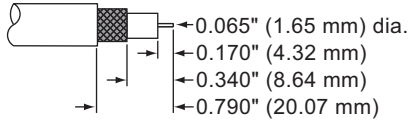
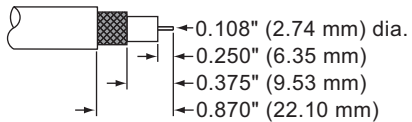
RG-11	
Max. length	100 ft (30 m)
KVH part no.	50 ft (15 m): S32-0566-50 100 ft (30 m): S32-0566-0100
Connector	Belden SNS11AS*
Tools	Belden CST596711, L3011B (KVH part no. 72-0493)
Strip lengths	
LMR-400-75	
Max. length	200 ft (60 m)
KVH part no.	100 ft (30 m): S32-0944-0100 150 ft (45 m): S32-0944-0150 200 ft (60 m): S32-0944-0200
Connector	Times Microwave EZ-400-FMH-75*
Tools	Times Microwave TK-400EZ-75 (KVH part no. 72-0374-75**)
Strip lengths	
LMR-600-75	
Max. length	325 ft (100 m)
KVH part no.	150 ft (45 m): S32-0945-0150 200 ft (60 m): S32-0945-0200 300 ft (90 m): S32-0945-0300
Connector	Times Microwave EZ-600-FMH-75*
Tools	Times Microwave TK-600EZ (KVH part no. 72-0375-75**)
Strip lengths	

* Cables from KVH include the proper connectors.

** LMR tool kits from KVH include a torque wrench.

8

Continued Prepare the Antenna Cables

Connect the Customer's RF Cables to the Supplied Pigtail Cables

IMPORTANT!

Use of the supplied pigtail cables is **mandatory**. Do not connect the customer's RF cables directly to the antenna.

- a. Clean and dry the RF cables' connectors.
- b. **Label both ends** of the customer's RF cables. Label one cable "TX," and label the other "RX."
- c. Heat shrink is supplied with each 3 ft (90 cm) pigtail cable to protect the connection between the customer's RF cables and the pigtail cables. Slide a heat shrink sleeve onto the end of each 3 ft (90 cm) pigtail cable (opposite the boot end) for later use.
- d. Fill half of the inner body of the customer's "TX" RF cable's connector with the supplied silicone grease to prevent moisture and corrosion.
- e. Connect and **SLOWLY** hand-tighten the "TX" RF cable to the feed-thru adapter of one of the supplied LMR-400-75 pigtail cables, allowing the grease to diffuse and settle into the entire space within the connector (see Figure 15).
- f. Make sure the RF cable's connector is tightened all the way into the pigtail cable's feed-thru adapter. Then tighten it with a 7/16" torque wrench set to 20 in.-lbs.
- g. Seal the RF cable-to-pigtail connection using silicone sealant, self-vulcanizing tape, or equivalent. Then protect the connection with the heat shrink (see step c).
- h. Repeat steps d-g to connect the "RX" RF cable to the other pigtail cable.

Figure 15: Connecting the Pigtail Cables to the RF Cables

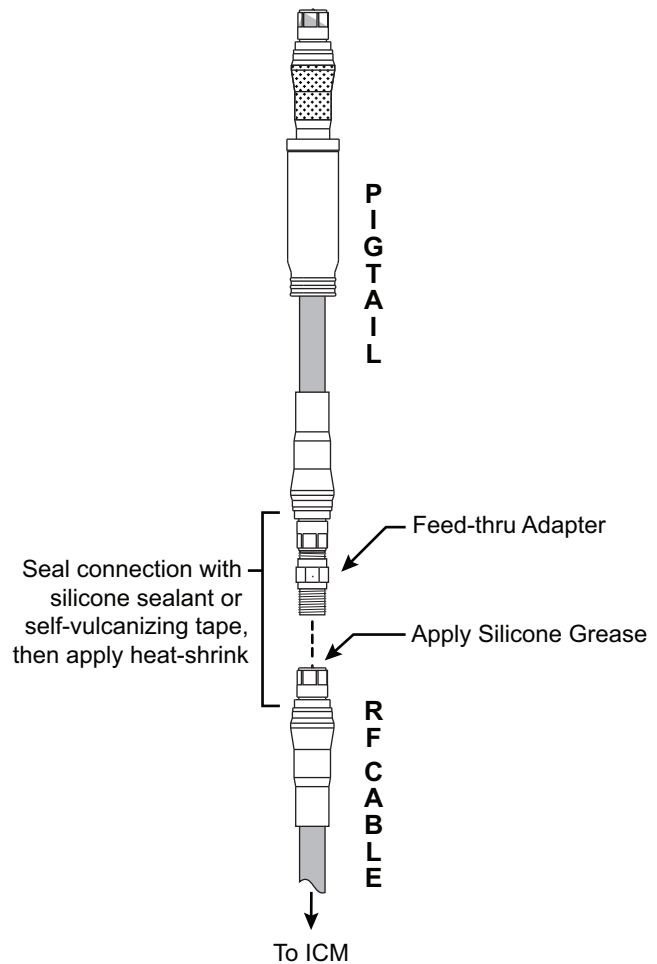

8

Continued Prepare the Antenna Cables

Route the Cables Belowdecks

- a. Keep the connector end of the power/data cable and the pigtail ends of the RF cables at the antenna location.

NOTE: Longer cables are available from KVH (see Figure 16).

- b. Route the opposite ends of the power/data and RF cables belowdecks through the 2" (55 mm) cable access hole. Leave an adequate service loop, at least 14" (35 cm) in diameter, at the antenna location for easy serviceability. (Total extra length of RF cables should not exceed 6.5 ft (2 m) at each end.)
- c. Route the cables to the ICM. Be sure to always maintain the minimum bend radius in the RF cables (see Figure 17). Later, you will connect these cables to the ICM.

Figure 16: Longer Power/Data Cable Options

Length	Part Number
150 ft (45 m)	32-1178-0150
200 ft (60 m)	32-1178-0200
300 ft (90 m)	32-1178-0300

Figure 17: Minimum Bend Radius of RF Cables

Cable Type	Minimum Bend Radius
RG-11	4.5" (11.5 cm)
LMR-400-75	4.5" (11.5 cm)
LMR-600-75	6" (15.3 cm)

9 Wire the Antenna

Follow these steps to connect the antenna cables.

Connect the RF Pigtail Cables

NOTE: The RF connectors may be more easily reached through the service hatches. To open a service hatch, use a Phillips-head screwdriver to remove its eleven M4 screws (see Figure 18).

- a. Clean and dry the antenna's two RF connectors, labeled "MTX" and "MRX" (see Figure 19).
- b. Pass the RF cables through the hole in the center of the antenna's baseplate.

Figure 18: Service Hatch/Hardware

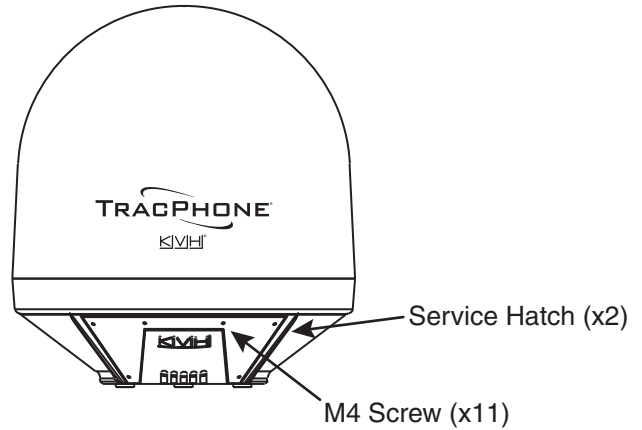
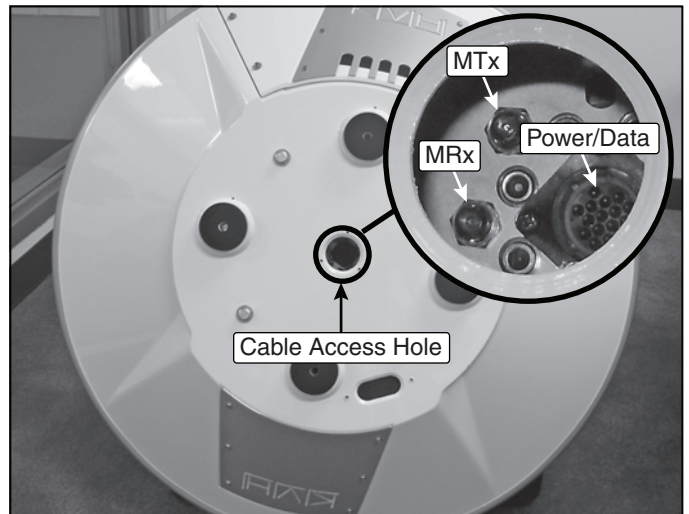

Figure 19: Connectors on Bottom of Antenna



9 Continued Wire the Antenna

- c. Place one of the supplied rubber connector washers over the "MTX" jack on the bottom of the antenna, as shown in Figure 20.
- d. Fill half of the inner body of the "TX" pigtail cable's male connector with silicone grease.
- e. Connect and **SLOWLY** hand-tighten the "TX" pigtail cable to the antenna's "MTX" jack, allowing the grease to diffuse and settle into the entire space within the connector.
- f. Make sure the "TX" pigtail cable's connector is tightened all the way into the antenna's connector and the rubber washer is compressed against the antenna's connector plate. Then tighten the connector with a 7/16" torque wrench set to 20 in.-lbs.
- g. Apply a thin layer of silicone grease to the jacket of the "TX" pigtail cable, along the wider segment at the base of the connector.
- h. Slide the rubber boot up the cable until it covers the entire connector and mates with the rubber washer. This will protect the connection from the elements.
- i. Wipe off any excess grease from the cable.
- j. Repeat steps b-h to connect the "RX" pigtail cable to the antenna.

Figure 20: Connecting the RF Pigtail Cables to the Antenna

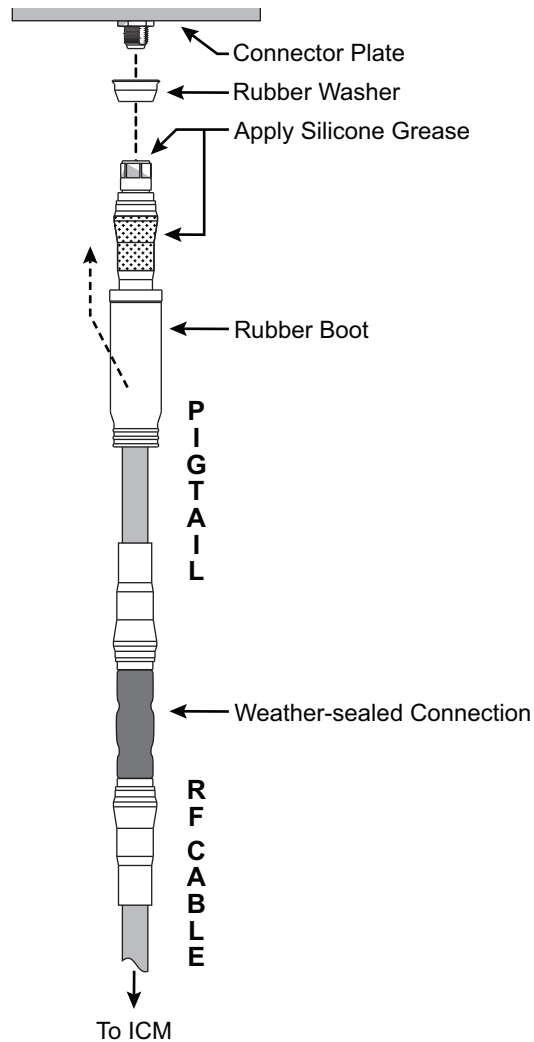

9 Continued Wire the Antenna

Connect the Power/Data Cable

- Pass the power/data cable through the hole in the center of the antenna's baseplate. Connect the power/data cable to the "Power/Data" jack on the bottom of the antenna (see Figure 21). Hand-tighten until the connector locks in place; do not use excessive force.
- Connect the power/data cable's ground strap to the 1/4"-20 ground screw on the bottom of the antenna (see Figure 21). Be sure to secure the ground strap's ring terminal between the screw and the washer.

NOTE: If it was necessary to access the service hatches, they can now be reinstalled. Secure each service hatch using the eleven M4 screws.

Protect the Cables

- Secure the cables near the antenna connectors to relieve stress (see Figure 22).
- Weatherproof and seal the cable access hole, as required.

IMPORTANT!

The integrity and reliability of the RF cables and their connections are critically important. Make certain that these cables are properly terminated, sealed against seawater and corrosion, strain-relieved, protected from abrasion, and free of stress.

Figure 21: Antenna Power/Data Cable Connections

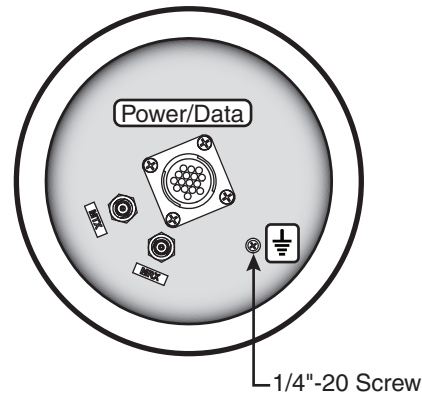
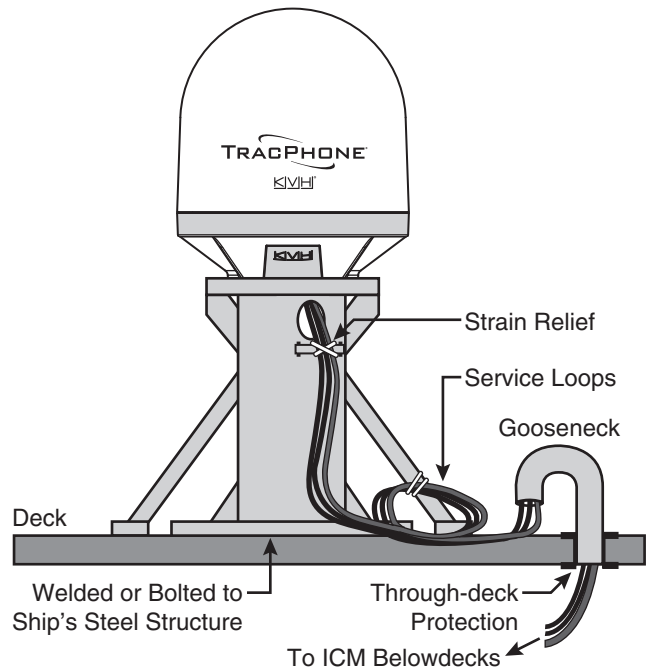

Figure 22: Strain-relief Example



10 Mount the Antenna

Follow these steps to mount the antenna to the mounting surface.

- a. Place the antenna over the holes drilled in the mounting surface. Make sure the forward arrow inside the baseplate points toward the bow and is parallel to the vessel's centerline (see Figure 23). The antenna's baseplate should rest squarely atop the foam seal.



CAUTION

Be sure to observe the safe handling instructions in the Material Safety Data Sheet (MSDS) provided with the anti-seize lubricant.

- b. Apply a thin layer of the supplied anti-seize lubricant to the threads of the four M10 mounting bolts to prevent galling.
- c. Using a 17 mm socket, secure the antenna to the mounting surface using four M10 bolts and flat washers from below (see Figure 24). Tighten all four bolts until the four rubber feet on the baseplate are bottomed against the mounting surface and the foam seal is fully compressed. KVH recommends that you tighten the bolts to 21 ft-lbs (28 N-m) of torque.
- d. Reinstall the radome onto the antenna baseplate. Secure in place with the eight #10-32 screws you removed earlier.
- e. Install a protective plastic screw cap (supplied in the kit) over each radome screw.

Figure 23: Forward Arrow in Antenna Baseplate

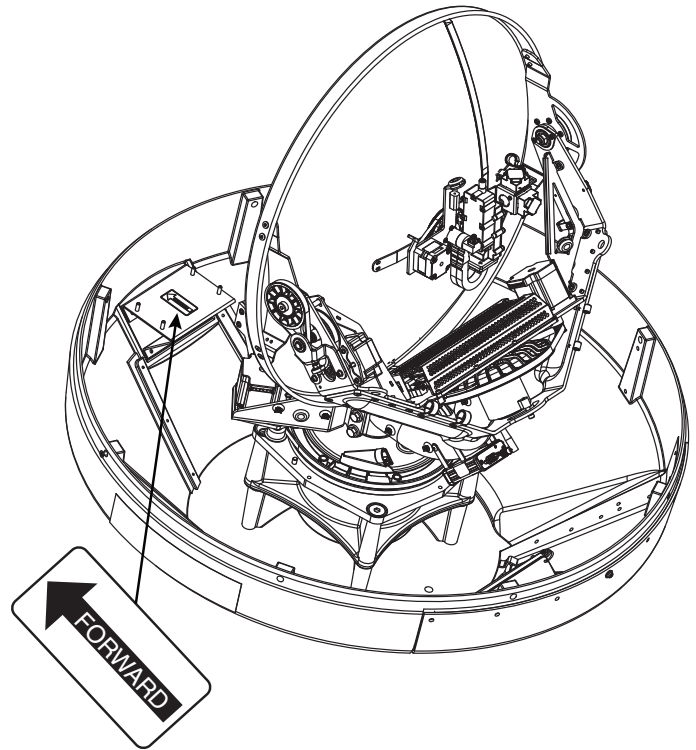
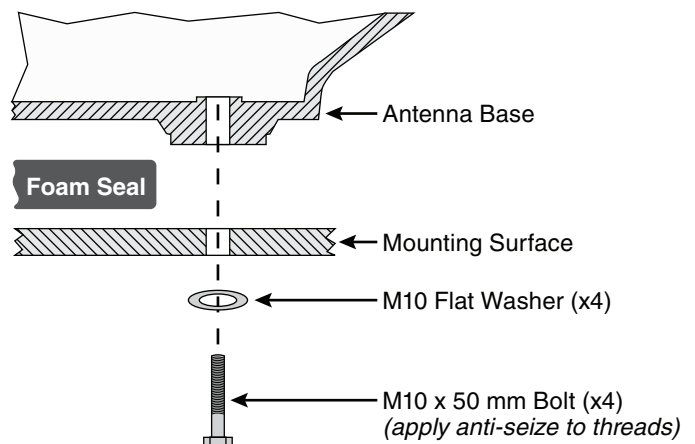

Figure 24: Mounting the Antenna (Side View)



11 Prepare the Power/Data Cable

If you cut the power/data cable to a certain length, perform all of the steps below. If the belowdecks end of the cable is intact as provided from the factory, skip to step j on the next page.

- a. Measure 10" (25 cm) back from the end of the cable. Then, using a utility knife to carefully cut in a rocking motion, sever just the cable's plastic jacket (outermost layer). Twist off the length of the plastic jacket (see Figure 25).
- b. At the end closest to the jacket, carefully pinch the cable braid to create a bulge. Then extract the silver drain wire from the braid (see Figure 26).
- c. Cut the braid at the center of the bulge and trim the braid up to the edge of the jacket (see Figure 27).
- d. Trim the foil insulation and fiber to the edge of the jacket so that only the power/data and drain wires remain (see Figure 28).
- e. Slide the supplied $\text{\O}0.063"$ ($\text{\O}1.6\text{ mm}$) heat shrink sleeve onto the drain wire. The wire should protrude from the end of the sleeve.
- f. Using a heat gun, apply heat evenly to the drain wire's heat shrink sleeve from one end to the other until it conforms to the wire.
- g. Insert the drain wire into the supplied ring terminal and crimp it into place (see Figure 29).

Figure 25: Stripping the Jacket

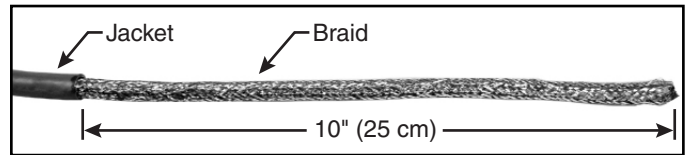

Figure 26: Extracting the Drain Wire

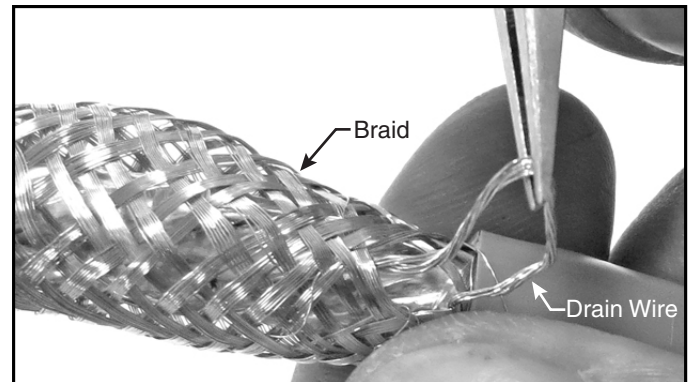

Figure 27: Trimming the Braid

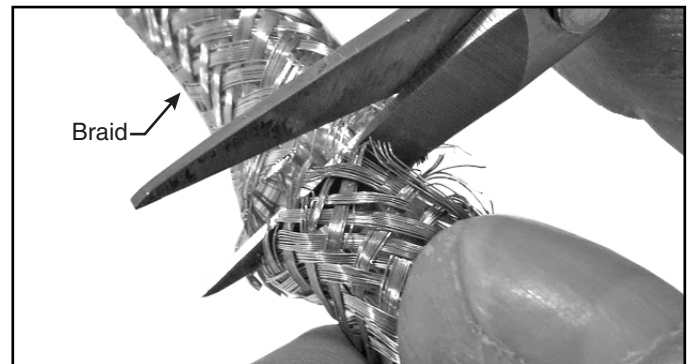

Figure 28: Trimming the Foil and Fiber

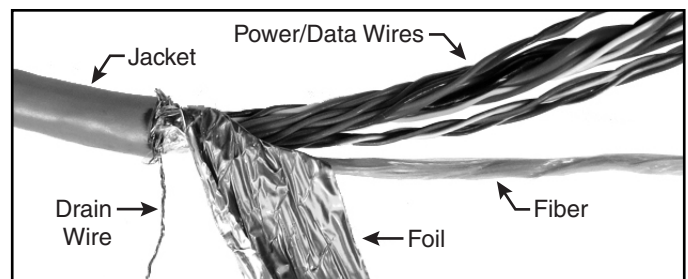
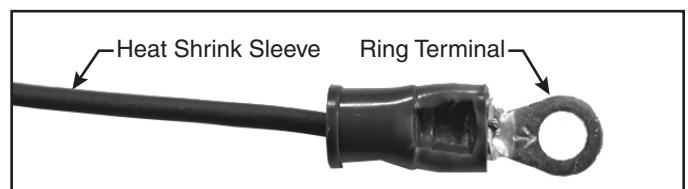

Figure 29: Crimping On the Ring Terminal



11 Continued Prepare the Power/Data Cable

- h. Trim approximately 3" (75 mm) from the ends of the power/data wires.
- i. Strip back the insulation of each wire approximately 1/4" (6 mm) and gently twist each wire to ensure a good electrical connection.
- j. Thread the power/data wires through the supplied Ø1.0" (Ø25.4 mm) heat shrink sleeve, ferrite cylinder, and plastic strain-relief tube, in that order (see Figure 30). Do not pass the drain wire through these components.

Be sure the ferrite cylinder abuts the edge of the jacket at one end and the edge of the strain-relief tube (opposite the flange) at the other end.

- k. Place the cable onto the base of the supplied cable shroud so that the strain-relief tube is seated properly in the bracket (see Figure 31). Later, you will secure the cable here with a clamp.
- l. Slide the heat shrink sleeve up the cable until it abuts the edge of the cable shroud. Hold the heat shrink sleeve in this position.
- m. Remove the cable from the shroud.
- n. Using a heat gun, apply heat to the heat shrink sleeve evenly, from one end to the other, until it conforms to the cable (see Figure 32).

Figure 30: Positioning the Ferrite Cylinder and Strain-relief Tube

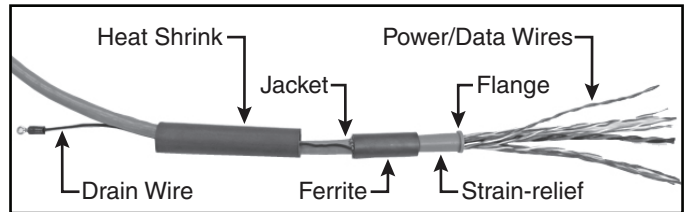

Figure 31: Positioning the Heat Shrink Sleeve

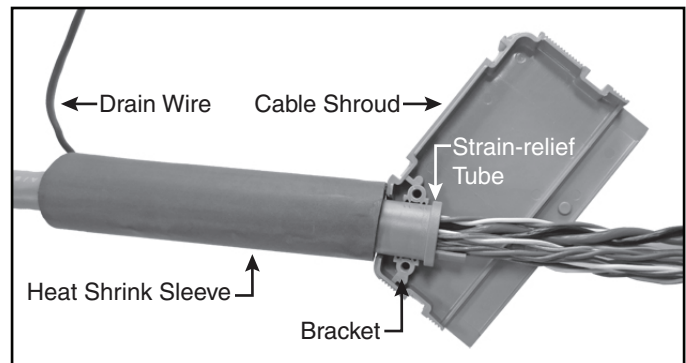
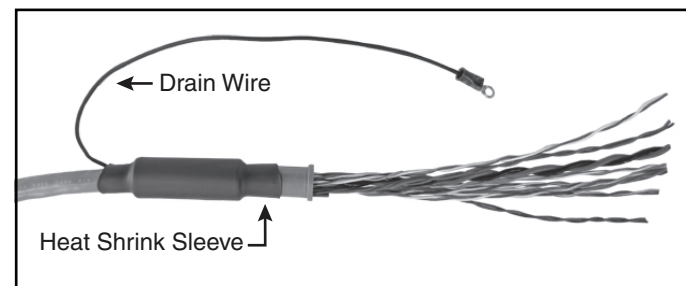

Figure 32: Prepared Power/Data Cable



12 Wire the ICM

Follow these steps to wire the belowdecks equipment (see page 55 for a complete wiring diagram).

Connect the Antenna Power/Data Cable

- a. Connect the antenna power/data cable to the supplied 16-position terminal strip connector as shown in Figure 33.

IMPORTANT!

The diagram refers to wires by **body color/stripe color**. For example, "Brown/White" means the brown wire with white stripe.

- b. Place the terminal strip connector into the base of the supplied cable shroud as shown in Figure 34.
- c. Secure the end of the power/data cable to the base of the shroud using the supplied clamp. This clamp will help relieve stress on the cable. Secure the clamp in place with the two screws.
- d. Carefully fit all of the power/data cable's wires (except the drain wire) within the base of the shroud.
- e. Snap the shroud's cover onto the base. Be sure not to pinch any wires between the cover and the base.
- f. Plug the terminal strip connector into the rear panel of the ICM.
- g. Connect the drain wire of the power/data cable to either ground point on the rear panel of the ICM.

Figure 33: Antenna Power/Data Wiring

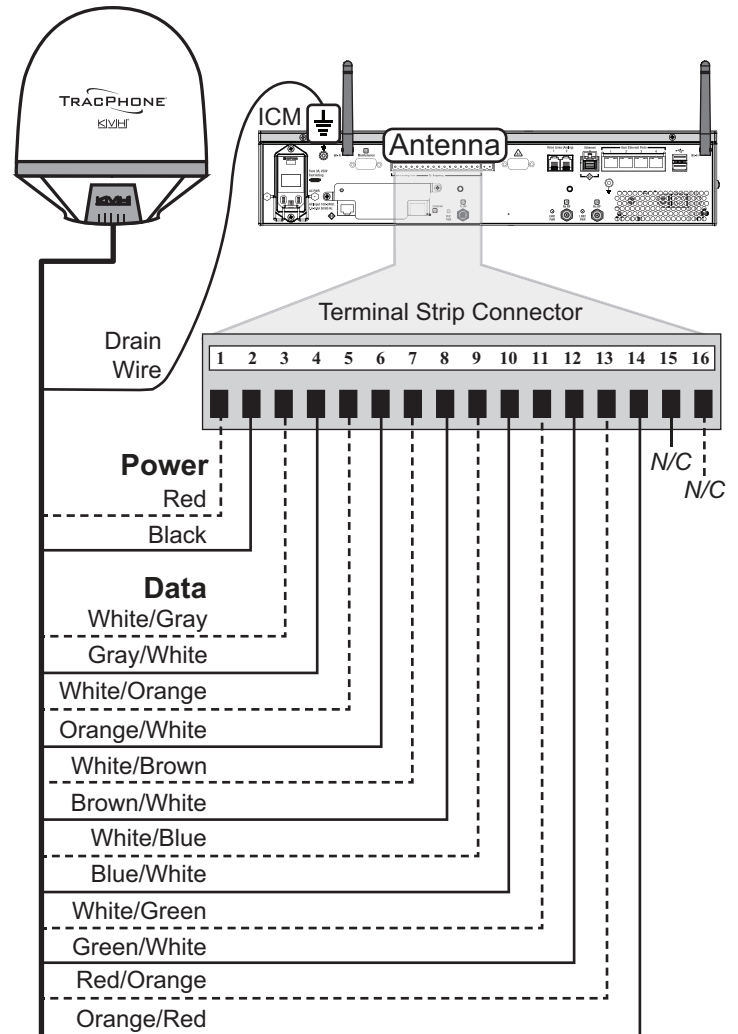

Two unused wires are reserved for future use; N/C = Not Connected

Figure 34: Power/Data Cable Shroud

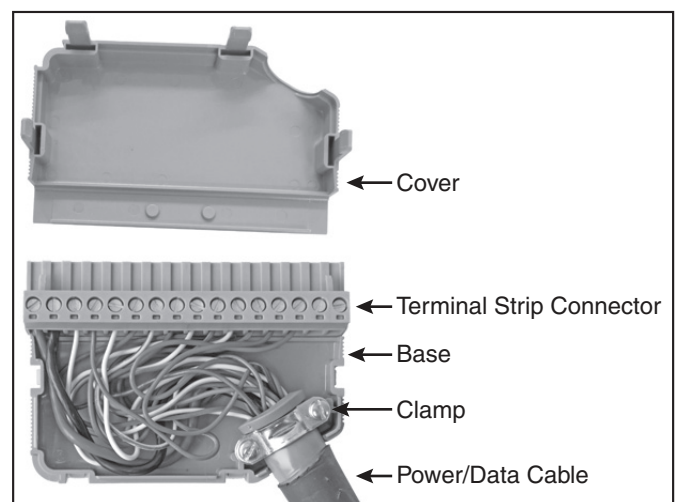

12 Continued Wire the ICM

Connect an NMEA 0183 Talker

The antenna **requires** a vessel heading input from a customer-supplied NMEA talker. Optionally, you can also provide a vessel position input to serve as a backup to the antenna's internal GPS.

To supply both the required heading and the optional position to the ICM, you can either connect an NMEA 0183 talker that transmits both messages, or connect two devices using an NMEA data multiplexer, such as Actisense® model NDC-4.

- a. Configure the customer's NMEA 0183 talker(s) to transmit a compatible message or messages at 4800 baud (see Figure 35).

NOTE: The system does not accept messages that conform to the NMEA 2000 standard.

- b. Make sure the data message(s) includes the checksum, identifiable by a *xx field at the end of the data sentence (e.g., \$HEHDT,123.4,T*1F). Do not exceed a 10 Hz input rate.
- c. Connect the NMEA 0183 talker or NMEA data multiplexer to the supplied 2-position terminal strip connector as shown in Figure 36.
- d. Plug the terminal strip connector into the rear panel of the ICM.

Figure 35: Compatible NMEA 0183 Inputs

Data Type	Compatible Messages
True or Magnetic Heading	\$--HDG \$--HDM \$--HDT \$--OSD \$--THS \$--VHW
Position	\$--RMC

Figure 36: NMEA Wiring

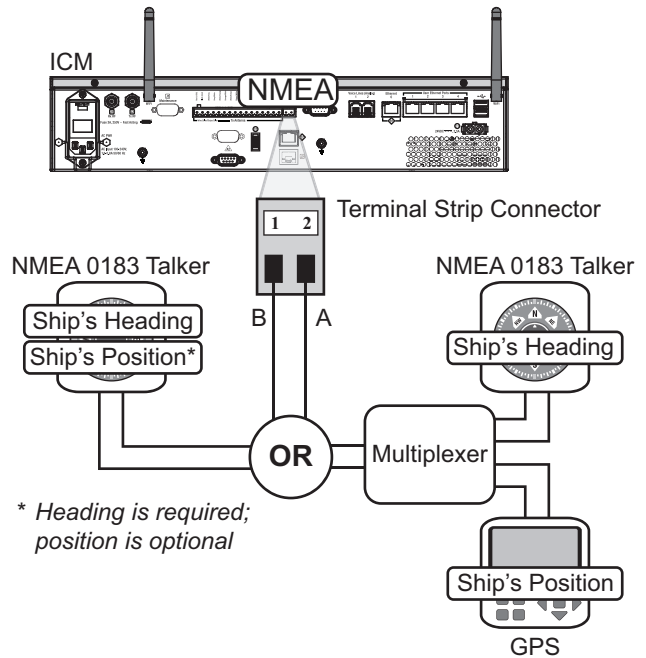

12 Continued Wire the ICM

Connect the RF Cables

IMPORTANT!

If you are using LMR-600-75 RF cables, do not connect them directly to the ICM. Connect the supplied 1 ft (30 cm) pigtail cables between the RF cables and the ICM. Be sure to use the pigtail cable labeled "TX ONLY" at the ICM's "Tx RF" jack.

- Connect the RF coax cable labeled "RX" to the "J1 Rx RF" jack on the back of the ICM (see Figure 37). Hand-tighten, then tighten with a 7/16" torque wrench set to 20 in.-lbs.
- Connect the RF coax cable labeled "TX" to the "J2 Tx RF" jack on the back of the ICM. Hand-tighten, then tighten with a 7/16" torque wrench set to 20 in.-lbs.

IMPORTANT!

Be sure the RF cables are terminated properly with type "F" connectors.

- Remove the tag from the "J4 Rx RF" jack on the back of the ICM (see Figure 38). Then connect the supplied RF terminator to the "J4 Rx RF" jack according to the tag's instructions. Hand-tighten, then tighten with a 7/16" torque wrench set to no more than 20 in.-lbs.

IMPORTANT!

The RF terminator (KVH part no. 19-0972) must be installed on the "J4 Rx RF" jack. Improper cable installations are not covered under KVH warranty.

Figure 37: Antenna RF Transmit and Receive Wiring

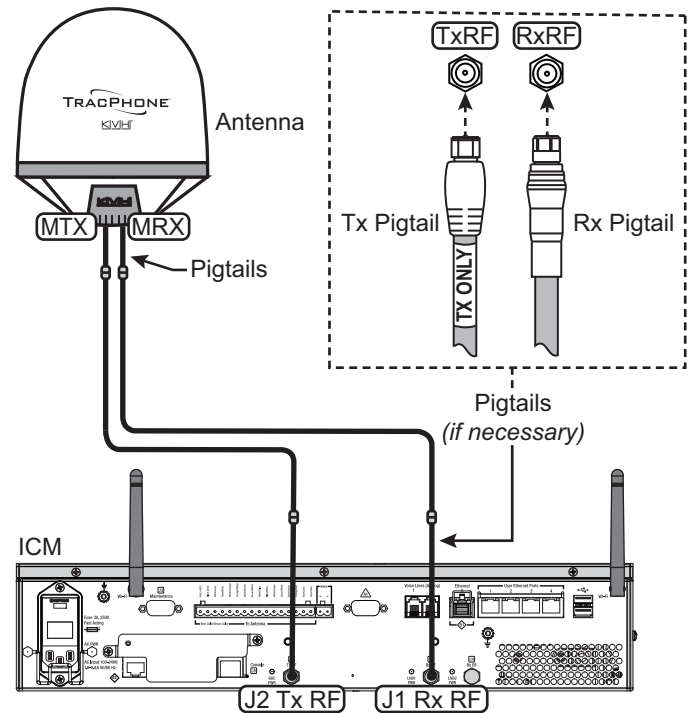
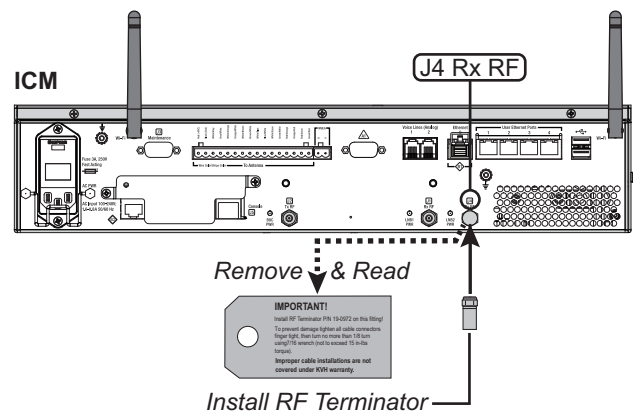

Figure 38: RF Terminator and Instructions Tag



13 Connect Power

Before you begin, be sure that you understand the following important requirements:

AC Power Requirements

The TracPhone system is designed to run on 3-wire single-phase AC power (hot, neutral, and ground). Voltage between hot-neutral and hot-ground should each measure between 100-240 VAC (see Figure 39).

Many large ships use two-phase, split-phase, or delta power instead (3 wires: hot, hot, and ground; no neutral). In this case, voltage between hot-hot measures the proper voltage (100-240 VAC); while hot-ground measures only half the voltage (50-120 VAC). Although the TracPhone system can operate on this type of power, the excess voltage present on the second phase will cause a small amount of current to leak onto ship's ground. This leakage current might be unacceptable on some vessels. So check with the customer or ship's electrician and get permission before you run the system on two-phase power. Also be sure to ground the system, as explained below.

If two-phase power is the only available power source onboard, and if leakage current is unacceptable, KVH recommends that you install a suitable isolation transformer to supply single-phase power to the antenna system and run a ground wire from the transformer to ship's ground. In addition, since ground fault protection devices cannot detect faults behind a transformer, you will also need to install a ground fault monitoring device between the isolation transformer and the antenna system if ground fault protection is required on the vessel.

Grounding Requirements

Proper grounding of the TracPhone system to ship's ground is critically important, as it protects the equipment from electrostatic discharges (ESD). Failure to ground the chassis of the ICM risks damage to the antenna and electric shock.

Figure 39: AC Power Options

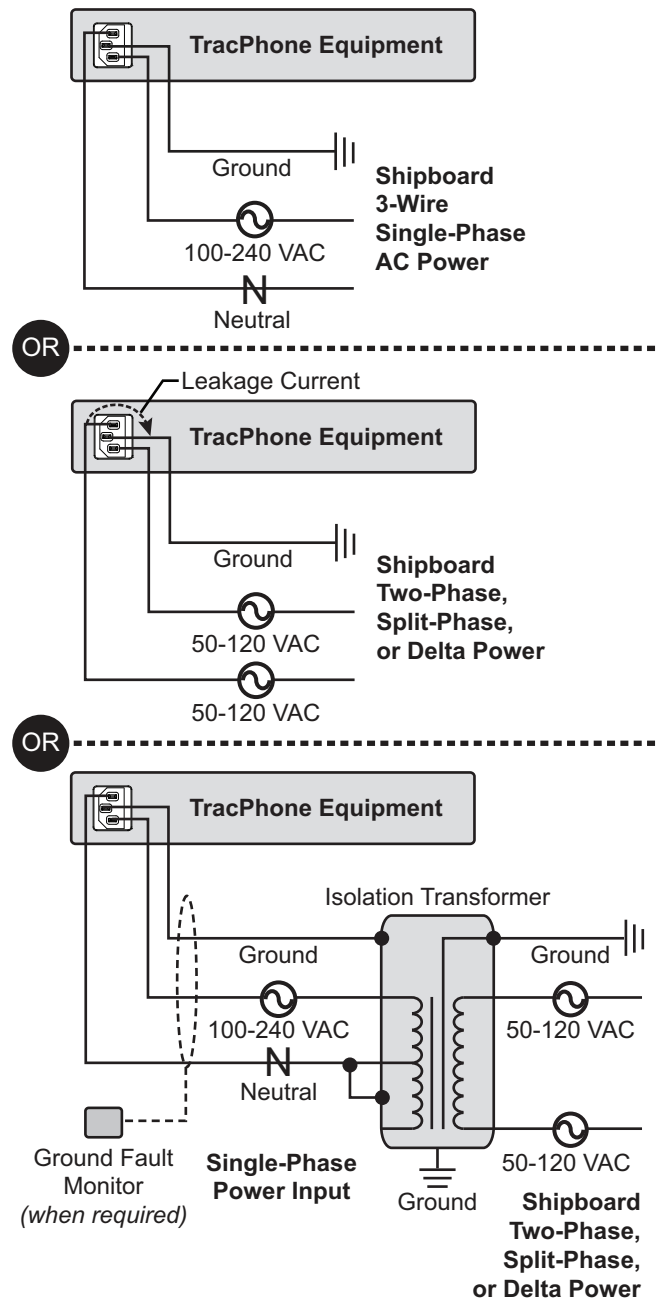

13 Continued Connect Power

Once you have read and understand the requirements described on page 23, follow these steps to connect power to the TracPhone system.

- a. Before you begin, disconnect vessel power and be sure the vessel is properly grounded in accordance with marine standards.
- b. Connect the supplied ground wire from the ground point on the ICM rear panel to ship's ground (see Figure 40).
- c. Connect the supplied AC power cord to the ICM.



WARNING

Failure to ground the TracPhone system properly to ship's ground will cause an unsafe floating ground condition, risking damage to the antenna and electric shock, potentially resulting in DEATH. In a floating ground condition, the difference between the equipment's chassis ground and the ship's ground can measure well over 100 volts, when it normally should not exceed 2 volts. Therefore, always measure the difference in potential between chassis ground and ship's ground to make certain that there is no dangerous floating ground condition, even if the ground pin of the vessel's AC power plug appears to be intact.

- d. Using tie-wraps, secure all wires to the strain-relief bracket at the back of the ICM (see Figure 41). Leave enough slack for easy serviceability.
- e. Double-check all of your wiring.
- f. Plug the ICM power cord into the vessel's 100-240 VAC supply.

NOTE: Consider installing an uninterruptible power supply (UPS) to avoid service interruptions during power outages and transitions to/from shore power.

Figure 40: Power Wiring

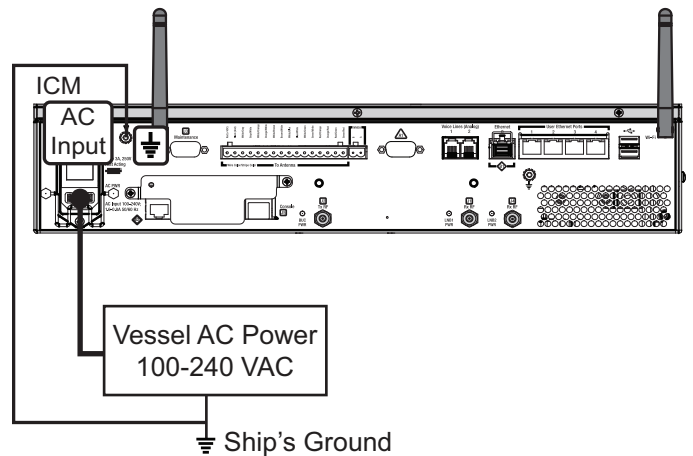
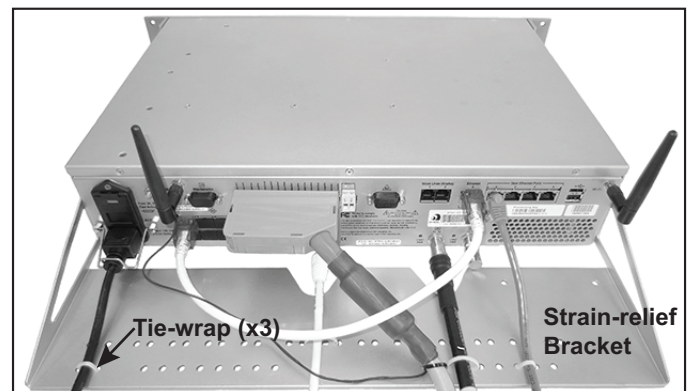

Figure 41: Strain-Relief Bracket



14 Turn On the System

Follow these steps to turn on the system.

- a. Ensure the antenna has a clear, unobstructed view of the sky.
- b. Apply vessel power to the TracPhone system.
- c. Press the power button on the front of the ICM (see Figure 42). The button's light should illuminate blue.
- d. Measure the AC and DC voltages between the ground point on the ICM's rear panel (chassis ground) and ship's ground. Make sure you measure less than 2 VAC/2 VDC.
- e. Wait at least 5 minutes for system startup.
- f. After the startup sequence is complete, verify that the ICM's Control Unit status light is lit solid green and the Antenna and Modem lights are lit solid or flashing green (see Figure 43).
- g. Connect your PC to the "User Ethernet 1" port on the rear panel of the ICM (see Figure 44).
- h. Turn off the Wi-Fi on your PC and keep it turned off while connected to the ICM.
- i. Open a web browser on your PC and enter the following address: **http://minivsat.kvh.**

Verify that the TracPhone V7-HTS web interface appears in your browser. If the web interface is not displayed, enter the ICM's IP address (*you can find this address on the LCD: go to Settings > Network Settings > IP Assignments*) and make sure your PC is configured for DHCP (see page 50).

Figure 42: Power Button

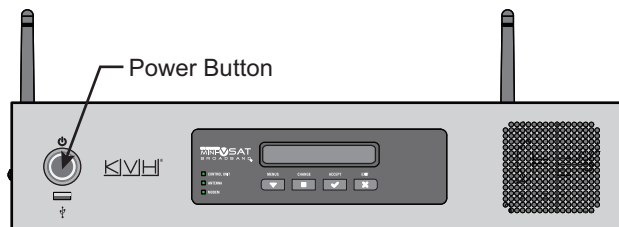

Figure 43: Status Lights

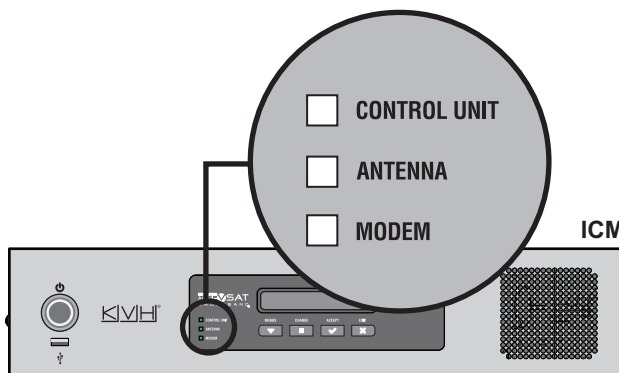
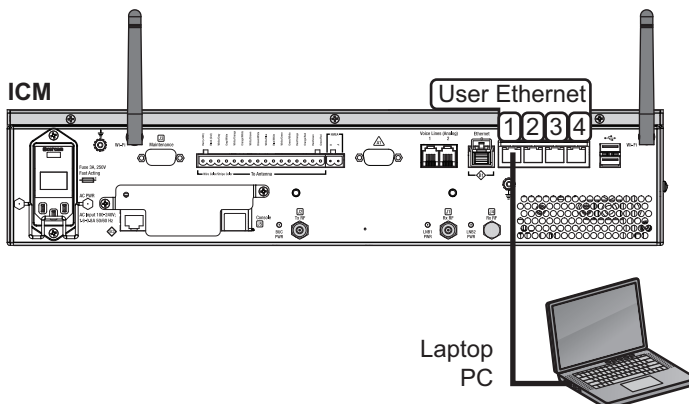

Figure 44: Connecting Your Laptop to the ICM



15 Update the System Software

If Necessary

Follow these steps to ensure the latest software is installed in the TracPhone system.

Check the Current Software Version

- a. Go to the TracPhone V7-HTS web interface and click the **Updates** tab. Note the displayed ICM/Antenna software version (see Figure 45).
- b. If the reported software version is earlier than the latest version you downloaded from the KVH Partner Portal, update the system following the steps below.

Update the Software, If Necessary

NOTE: This procedure explains how to update the software using the TracPhone V7-HTS web interface. However, you can also update the software using the mini-VSAT iPhone®/iPod Touch® app, a USB drive, or, if the system is activated, via the antenna's Internet connection (airtime charges may apply). Details are available in the Help.

- a. Click **Choose File**.
- b. At the Login window, enter the default password: “**password**”.
- c. Click **Browse** and navigate to the file you saved on your laptop (see Figure 46).
- d. Click **Check File**.
- e. At the confirmation message, click **Update**.
- f. Wait for the software update to complete. It might take up to 40 minutes.

Figure 45: Updates Page on Web Interface

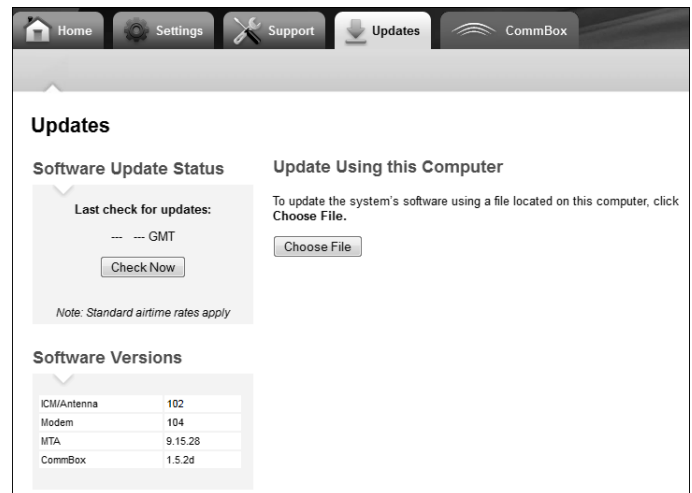
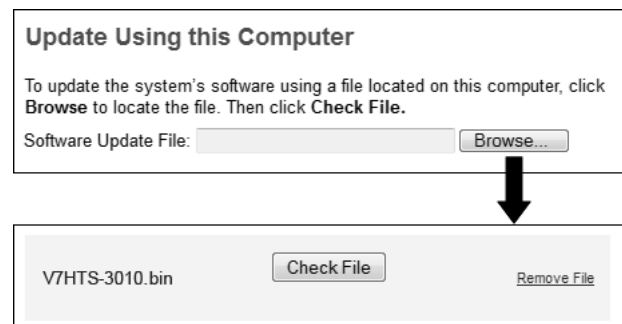

Figure 46: Update File Selected for Upload



16 Customize the Web Interface

Follow these steps to customize the web interface for the customer's use.

Set the Administrator Password

The user must be logged in as an administrator to make changes to the system's configuration. Follow these steps to change the administrator password to something unique.

- At the TracPhone V7-HTS web interface, click the **Settings** tab. Then click **Account**.
- In Security, click **Edit**.
- For the current password, enter the default password: "password" (see Figure 47).
- Enter and then re-enter the new password. Then click **Save Settings**.

Enter the Vessel Name

The vessel name is displayed on the home page and in all support communications. Follow these steps to enter the correct vessel name.

- At the TracPhone V7-HTS web interface, click the **Settings** tab. Then click **Account**.
- In Vessel Name, click **Edit**.
- Enter the vessel name (see Figure 48). Then click **Save Settings**.

Assign Phone Line Name(s)

The phone line names are displayed on the home page and in all support communications. Follow these steps to assign a name (i.e., location) to each active phone line (second line is optional).

- At the TracPhone V7-HTS web interface, click the **Settings** tab. Then click **Other**.
- In Phone Line Names, click **Edit**.
- Enter names for Lines 1 and 2, as needed (see Figure 49). Then click **Save**.

Figure 47: Setting the Administrator Password

The screenshot shows a web form titled "Security". Below the title is the instruction "Change the administrator's login password." There are three password input fields: "Enter the current password:" with a masked field of 8 dots; "Enter the new password:" with a masked field of 10 dots and a "Strong" indicator (a checkmark in a box) to its right. Below the new password field is a note: "(between 4 and 20 characters long, with at least one letter and one number, case sensitive)". The third field is "Re-enter the new password:" with a masked field of 10 dots. At the bottom right are "Cancel" and "Save Settings" buttons.

Figure 48: Entering the Vessel Name

The screenshot shows a web form titled "Vessel Name". Below the title is the instruction "Change the name displayed on the Home page and in support communications." There is a single text input field labeled "Vessel Name:" containing the text "Britanic". At the bottom right are "Cancel" and "Save Settings" buttons.

Figure 49: Assigning Phone Line Names

The screenshot shows a web form titled "Phone Line Names". Below the title is the instruction "The names displayed on the home page and in support communications (see example)". There are two text input fields: "Line 1:" containing "Bridge" and "Line 2:" containing "Crew Quarters". To the right of each field is a note: "(up to 25 characters)". At the bottom right are "Cancel" and "Save" buttons.

17 Set Up No-Transmit Zones

Optional

To prevent exposure to RF energy, which may be harmful to people who stand within 36 feet (11 meters) of the antenna, you can configure up to two no-transmit zones for areas where crew and/or passengers frequent (see Figure 50). The system will disable the transmitter whenever the antenna is pointing within one of these zones.

Follow these steps to set up a no-transmit zone.

- Determine the necessary azimuth range for the no-transmit zone(s). You will need to enter, in clockwise order, beginning and ending azimuths that define the outer boundaries of the zone(s) **relative to the antenna's forward arrow**, which should be pointing toward the bow (see Figure 51).
- Determine the necessary elevation range for each no-transmit zone(s) (see Figure 52).

NOTE: Each no-transmit zone must span at least 5° in both azimuth and elevation.

Figure 50: Example of No-Transmit Zone Azimuth Range

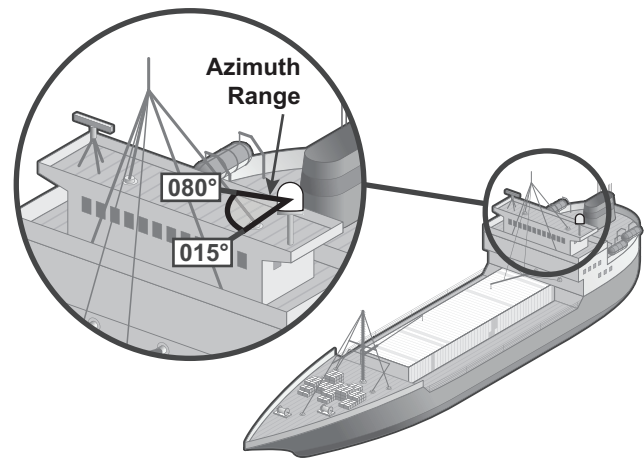

Figure 51: Azimuths Relative to Antenna's Forward Arrow

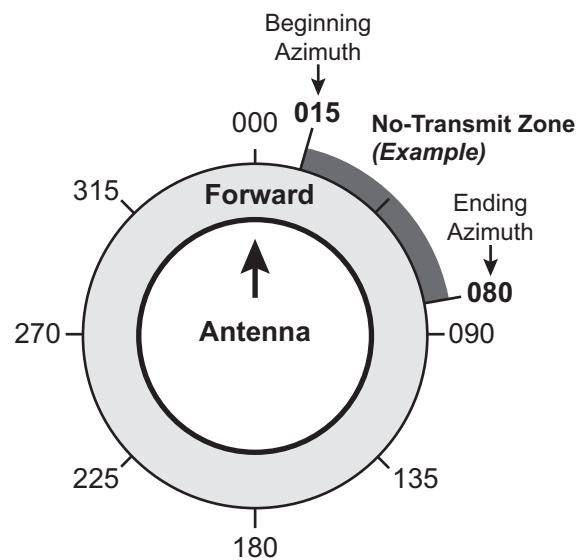
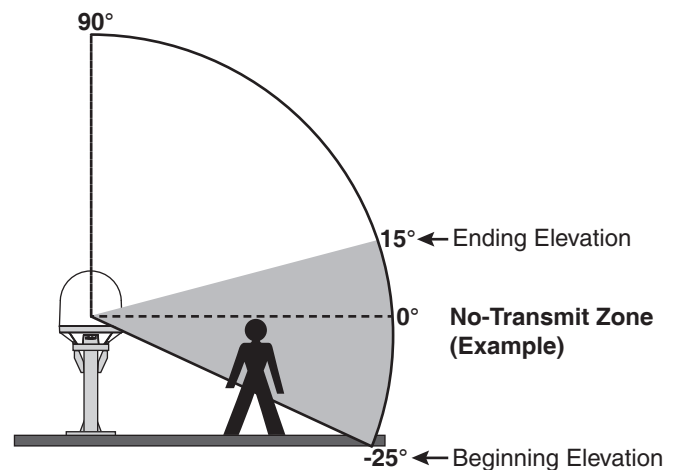

Figure 52: Example of No-Transmit Zone Elevation Range



17 Continued Set Up No-Transmit Zones

- c. At the TracPhone V7-HTS web interface, click the **Settings** tab. Then click **No-Transmit Zones**.
- d. Click **Edit**.
- e. Make sure **Enforce Zones** is selected (see Figure 53).
- f. Enter the azimuth and elevation ranges for Zone 1.
- g. If you need to set up a second zone, select Zone 2 from the drop-down menu. Then enter the azimuth and elevation ranges for Zone 2.
- h. Click **Save Settings**.
- i. At the confirmation message, click **Save**.

Figure 53: No-Transmit Zones Page of Web Interface

No-Transmit Zone Ranges:

- Enforce Zones**
The antenna will not transmit within the zone(s) specified below.
- Ignore Zones**
The antenna will be able to transmit in any direction without restriction. Be sure everyone stays the minimum safe distance away from the antenna.

Choose a No-Transmit Zone:

Zone 1

Zone 1

Azimuth Range:
Must span at least 5°

From: °
To: °

Elevation Range:
Must span at least 5°

From: °
To: °

Buttons:

The interface includes two circular diagrams. The top diagram is a 360-degree azimuth plot with labels every 30 degrees (0, 30, 60, 90, 120, 150, 180, 210, 240, 270, 300, 330). A shaded sector is shown between 15 and 80 degrees. The bottom diagram is an elevation plot with labels at 90, 60, 30, 0, and -25 degrees. A shaded sector is shown between -25 and 15 degrees. A small antenna icon is positioned at the center of the elevation plot.

18 Commission the Modem

Follow these steps to commission the ICM's built-in modem, if required.

IMPORTANT!

If the modem was commissioned at the factory (look for a notice attached to the ICM), you can skip this step as long as you are using RG-11 RF cables 80-100 ft (25-30 m) in length. If a notice is not attached to the ICM, or you used a different RF cable type or length, or you installed a different antenna from the unit that shipped with the ICM, you must complete this step.

This process is required to determine the 1 dB compression point of the BUC (block up-converter) (see Figure 54) and the maximum transmit power. The process takes about 30 minutes to complete.

- a. Ensure the antenna has a clear, unobstructed view of the sky.
- b. At the TracPhone V7-HTS web interface, verify that the antenna is tracking the service satellite and the system is online (see Figure 55).
- c. Click the **Support** tab and gather all the information listed on the Modem Commissioning Worksheet (supplied in the Welcome Kit).
- d. Call KVH Technical Support. KVH will coordinate with the Network Operations Center (NOC) to complete the remaining commissioning steps over the air. You will just need to provide the information you noted on the worksheet.

NOTE: If the NOC is unable to access the system remotely over the satellite connection, you will need to assist with the commissioning process by adjusting settings at the modem's local web interface as directed by the NOC. Refer to "Full Commissioning Steps" on page 40 for details.

Figure 54: BUC's 1 dB Compression Point Determination

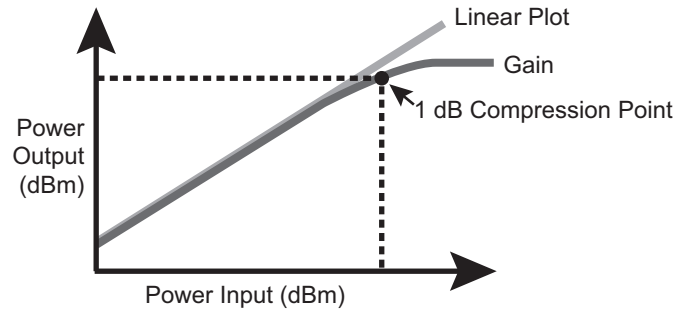

Figure 55: Good Service Connection Indicated on Home Page

My VSAT Status	
Connection Status	Antenna State
ONLINE SNR: 5.80dB	TRACKING

Figure 56: Modem Commissioning Worksheet Information

No.	Item	Value
①	Antenna State "TRACKING" required	
②	Orbital Slot	
③	Satellite Name (see table below)	
④	Beam ID	
⑤	Frequency	
⑥	Management IP	
⑦	Vessel Position	Lat:
		Long:
⑧	Modem State "IN_NETWORK" required	
⑨	FL Carrier Symbol Rate (2nd field)	
⑩	Modem S/N	

19 Test the System

Follow these steps to test the system for proper operation.

- a. Ensure the antenna has a clear, unobstructed view of the sky.
- b. Verify that the antenna is tracking the service satellite and the system is online, as indicated by the Home page of the TracPhone V7-HTS web interface (see Figure 57).
- c. On the Home page, make sure the vessel's heading is displayed in the Real-time Vessel & VSAT Satellite Display (see Figure 58). If it is not shown, check your wiring to the NMEA 0183 talker.
- d. Enter the following address in your web browser: <http://test.minivsat.net>.

Verify that the Welcome page appears, indicating good communication between the TracPhone system and the land-based hub (see Figure 59).
- e. Turn on all other electronic equipment above deck within the proximity of the antenna. Verify that the system continues to operate without any degradation in performance.
- f. Fill out the Installation Checklist (provided in the Customer Welcome Kit) and return it to KVH. Refer to the instructions on the form.

IMPORTANT!

Submission of the Installation Checklist is **required** to certify the quality of your installation.

Figure 57: Good Service Connection Indicated on Home Page

My VSAT Status	
Connection Status	Antenna State
 ONLINE SNR: 5.80dB	TRACKING

Figure 58: Heading Displayed on Home Page

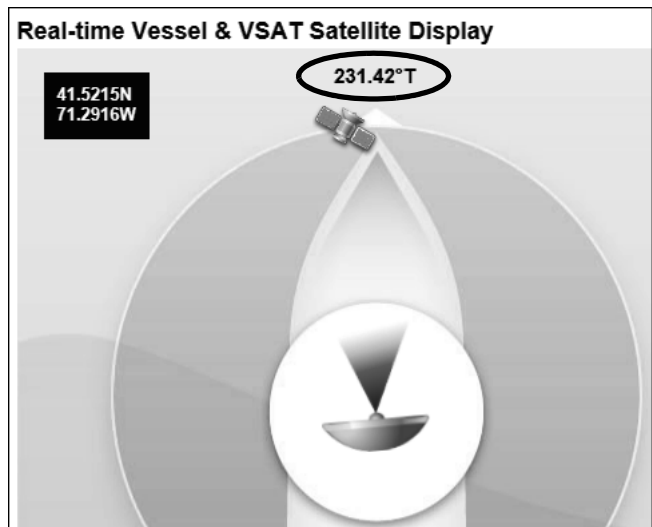
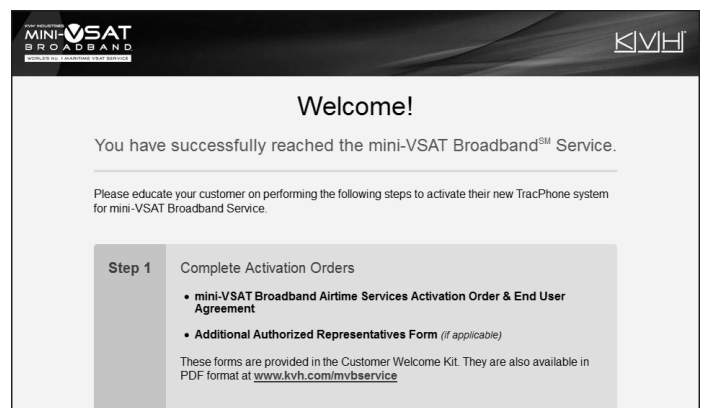

Figure 59: Welcome Page for Testing



20 Configure the Network

The ICM includes four Ethernet ports and a built-in wireless access point (WAP) that can be configured in a variety of ways to meet the customer's needs (see Figure 60). Some of the most common ICM network configurations can be selected directly from the TracPhone V7-HTS web interface. Follow these steps to select one of these configurations. If the customer requires a custom configuration, please contact KVH Network Services at networkservices@kvh.com.

NOTE: The customer may also change the ICM's network configuration at the mini-VSAT Manager (go to www.mykvh.com). To access myKVH, the customer will need to log in with the username and password provided by KVH at the time of activation.

IMPORTANT!

The TracPhone system provides two separate data paths for Internet access:

- **High-speed** – Fastest speeds; uses Open airtime plan that includes an allotment of data usage; overage charges apply
- **Unlimited** – Minimal speeds; uses Fixed-rate airtime plan

- At the TracPhone V7-HTS web interface, click the **Settings** tab. Then click **Network Settings**.
- In Network Configuration, click **Edit**.
- Select an option from the **Configuration** drop-down menu. Then click **Save** (see Figure 61 and Figure 62).
- At the confirmation message, click **Save**.
- Follow the additional instructions on the following pages for your chosen configuration.

Standard HTS: Go to page 33

Static IP HTS: Go to page 34

Open Access HTS: Go to page 35

Figure 60: ICM Ethernet Ports and Wireless Access Point

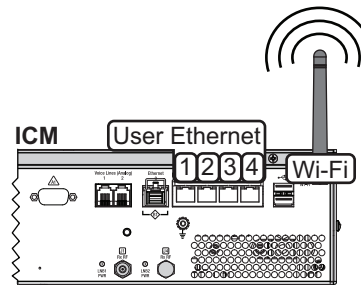

Figure 61: Selecting a Network Configuration

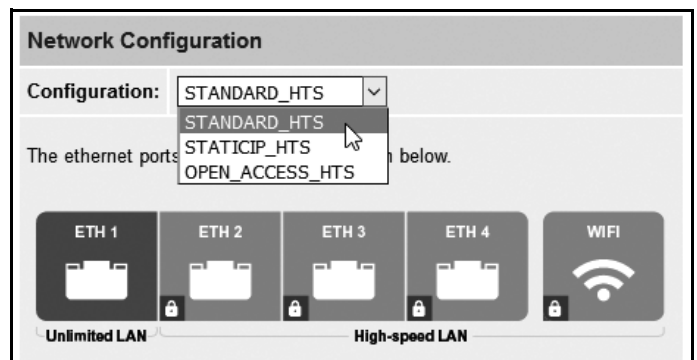

Figure 62: User Selectable Network Configurations

Option	Description
Standard HTS	Port 1: Unlimited LAN Ports 2-4, Wi-Fi: High-speed LAN with access control
Static IP HTS	Port 1: Unlimited LAN Ports 2-3, Wi-Fi: High-speed LAN with access control Port 4: Accessory LAN*
Open Access HTS	Port 1: Unlimited LAN Ports 2-3, Wi-Fi: High-speed LAN with unrestricted access Port 4: Accessory LAN*

* Accessory LAN reserved for optional service, such as Global Static IP, external MTA, or Crew Calling.

20 Continued Configure the Network

Standard HTS Configuration

In a Standard HTS configuration, Ethernet port 1 provides unlimited Internet access with no user logins or controls. Ports 2 through 4 and the built-in WAP require a user login and provide high-speed Internet access. This is the default configuration. Follow these additional steps to configure the network.

- To enable the ICM's WAP for wireless access, follow the steps in "ICM Wireless Settings" on page 36.
- Connect the customer's computers and/or other network devices to the ICM. Make sure you connect to the port(s) that correspond to the desired Internet connection path(s): Unlimited or High-speed (see Figure 64). You might wish to add an external WAP (or Wi-Fi router configured for bridge mode) to supplement Wi-Fi access.
- Make sure all computers are configured for DHCP addressing (see page 50). Devices connected to the ICM (via Ethernet cables or Wi-Fi) will receive IP addresses from the ICM via DHCP. The ICM serves as a router.
- Inform the customer that they need to set up user names and passwords and allocate data for each High-speed LAN user at the mini-VSAT Manager (www.mykvh.com).

NOTE: By default, the High-speed LAN has a gateway of 192.168.6.1 and assigns IP addresses in the 192.168.6.50-150 range. If this configuration conflicts with an existing onboard network, you may change the settings at the TracPhone V7-HTS web interface (go to Settings > Network Settings). The Unlimited LAN (gateway 192.168.5.1) cannot be changed at the web interface. If it conflicts with an existing network, please contact KVH Technical Support for assistance.

Figure 63: Standard HTS Configuration



Figure 64: Standard HTS Configuration Wiring Example

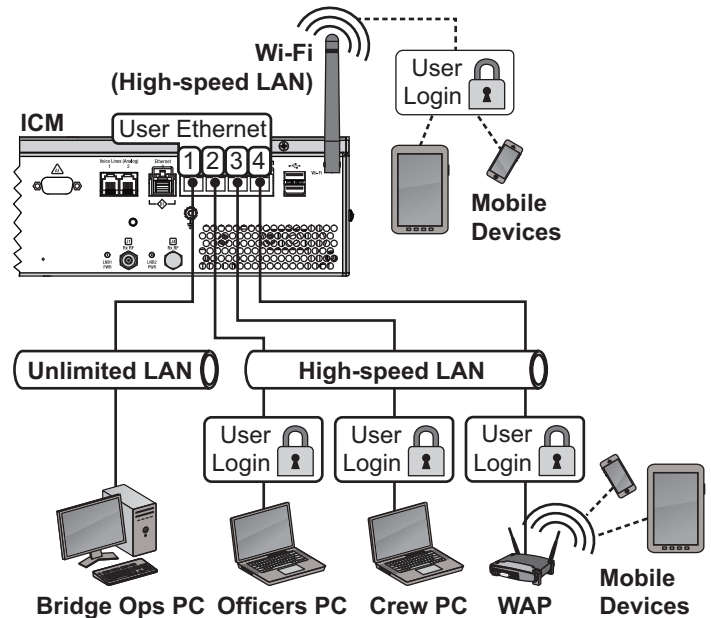

20 Continued Configure the Network

Static IP HTS Configuration

In a Static IP HTS configuration, Ethernet port 1 provides unlimited Internet access with no user logins or controls. Ports 2 and 3 and the built-in WAP require a user login and provide high-speed Internet access. Port 4 is reserved for an optional KVH service, such as Global Static IP.

Global Static IP service allows you to set up a network device with an IP address that can be accessed directly from the Internet. It does not receive an IP address from the ICM. If you require Global Static IP Service, follow these additional steps to configure the network.

IMPORTANT!

A static IP address should only be assigned to a secure device, such as a firewall router.

- Ask the customer to fill out the request form at www.kvh.com/staticip. In addition, the system must be activated for mini-VSAT Broadband service, and it must remain online until KVH configures the system over the air.
- Connect the static IP device to "User Ethernet" port 4 on the ICM (see Figure 66).
- The customer will need to configure the device's TCP/IP properties according to the instructions KVH will provide in an email upon fulfilling the static IP request.
- Connect all other (non-static IP) computers and/or network devices to "User Ethernet" ports 1-3 and Wi-Fi, as required. Follow the steps in "Standard HTS Configuration" on page 33.

Figure 65: Static IP HTS Configuration

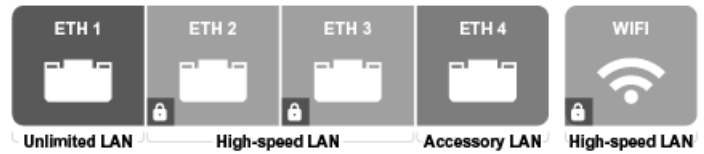
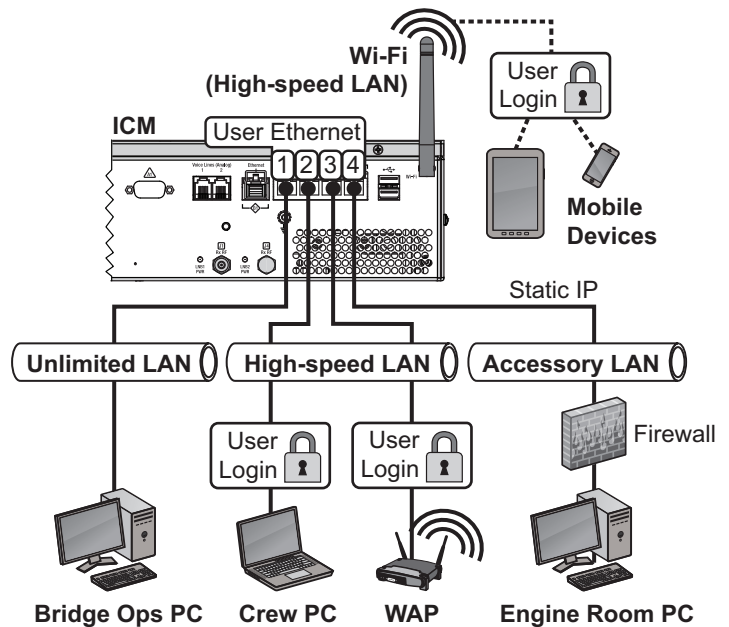

Figure 66: Static IP HTS Configuration Wiring Example



20 Continued Configure the Network

Open Access HTS Configuration

In an Open Access HTS configuration, Ethernet port 1 provides unlimited Internet access, and ports 2 and 3 and the built-in WAP provide high-speed Internet access, with no user logins or controls. Port 4 is reserved for an optional KVH service, such as Global Static IP.

This configuration is identical to the Static IP HTS configuration described on the previous page with one exception: user names/passwords and data allocations are not enforced to control access to the High-speed LAN. Internet access is unrestricted.

Figure 67: Open Access HTS Configuration

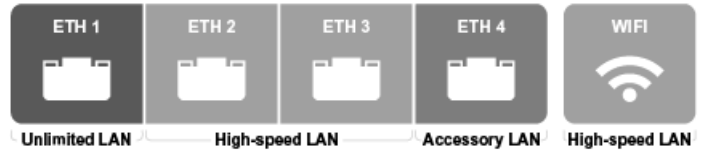
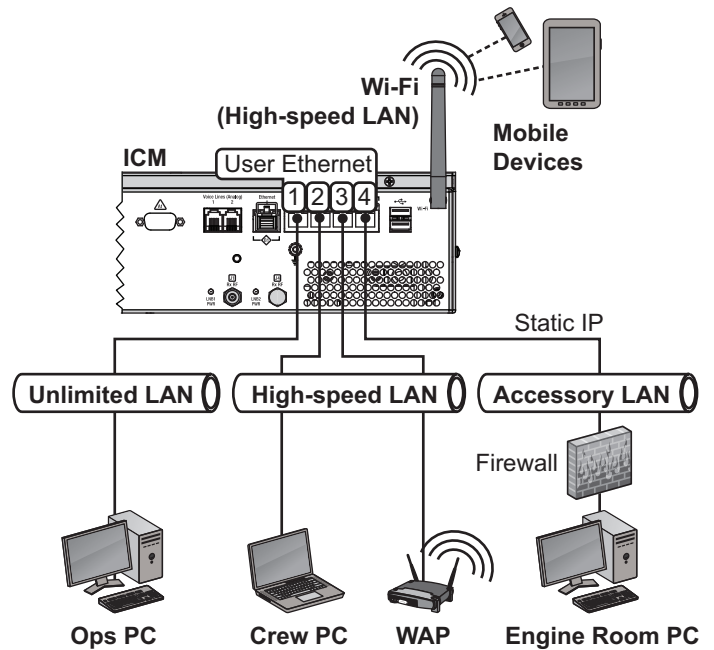

Figure 68: Open Access HTS Configuration Wiring Example



20 Continued Configure the Network

ICM Wireless Settings

With Wi-Fi enabled, vessel devices can connect to the ICM via its built-in wireless access point (WAP) and receive IP addresses from the ICM via DHCP (see Figure 69). Follow these steps to enable and configure the WAP, if desired by the customer.

IMPORTANT!

Establishing a wireless connection onboard a steel vessel might require a special external WAP and advanced networking expertise.

NOTE: The customer may also change the ICM's wireless settings at any time at the mini-VSAT Manager (www.mykvh.com).

- a. At the TracPhone V7-HTS web interface, click the **Settings** tab. Then click **Network Settings**.
- b. In Wi-Fi Settings, click **Edit**.
- c. Set the following wireless options, then click **Save** (see Figure 70):
 - **State:** Select On.
 - **SSID:** Enter a unique name for the vessel network.
 - **Protocol:** Select either 802.11b or 802.11g.
 - **Security:** Select either security type – WPA2 or WEP (128-bit).
 - **Password/Passphrase:** If you selected WPA2, enter a password (between 8-20 characters). If you selected WEP, enter a passphrase (must be 13 characters).
 - **Channel:** Keep the default, or select any channel for wireless communications.

IMPORTANT!

Failure to apply security settings will make the vessel's wireless network vulnerable to outside intrusion.

- d. At the confirmation message, click **Save**.

Figure 69: Wireless DHCP (Example)

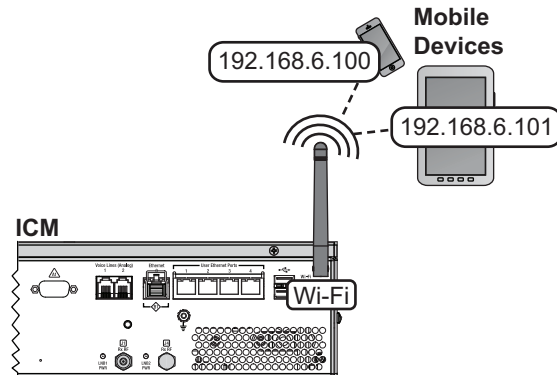

Figure 70: Wi-Fi Settings on the ICM

Wi-Fi Settings	
State:	<input checked="" type="radio"/> On <input type="radio"/> Off (default)
SSID:	<input type="text" value="MyVesselNetwork"/> (Up to 32 characters)
IP Address:	192 . 168 . 6 . 1
Protocol:	<input type="text" value="802.11b"/>
Security:	<input type="text" value="WPA2"/>
Password:	<input type="text" value="••••••••"/> (between 8 to 20 characters)
Channel:	<input type="text" value="7"/>
<input type="button" value="Cancel"/> <input type="button" value="Save"/>	

20 Continued Configure the Network

Optional CommBox Software

CommBox software extends the system's network capabilities (see Figure 71). Two options are available:

- **Standard Bundle:** Provides least cost routing, onboard firewall, web caching, web image compression, ad removal, and URL and content filtering
- **Enterprise Bundle:** Adds automated file transfers, differential synchronization, mail relay server, web mail client, anti-spam and anti-virus filters, roaming crew accounts, and prepaid Internet and email services; integration with a CommBox hub is required

KVH will coordinate directly with the customer to select, install, and configure the appropriate bundle to meet their needs.

Figure 71: Available CommBox Options

Option	KVH Part No.
CommBox Standard Bundle*	35-0010
CommBox Enterprise Bundle*	35-0011

* If the customer is interested in a CommBox solution, ask them to contact KVH Network Services at networkservices@kvh.com for a consultation.

21

Connect Voice Line Equipment

Follow these steps to connect the vessel's phone(s) and any purchased voice line accessories to the system.

Connect Vessel Phone(s)

Using the supplied RJ-11 cables, connect the customer's analog (not digital) phone(s), fax machine, and/or PABX to the desired "Voice Line" jack(s) on the ICM (see Figure 72). Each jack is linked to a phone line.

IMPORTANT!

The second phone line is optional – an additional monthly fee applies. If the customer has not purchased a second line, do not connect anything to "Voice Line 2."

Figure 72: Connecting Vessel Phones (Example)

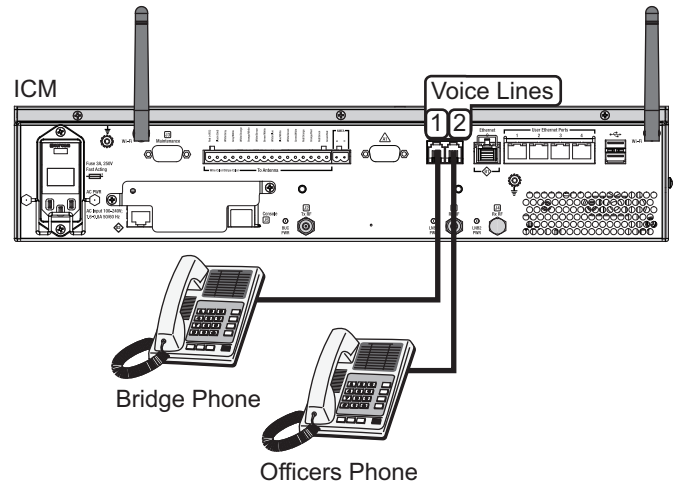

22 Educate the Customer

Give the Welcome Kit to the customer, make sure they know the differences between the Unlimited LAN and the High-speed LAN, give them the administrator and Wi-Fi passwords, and show them how to use the system. Be sure they understand the following:

- **The antenna transmits RF energy that is potentially harmful.** Whenever the system is powered on, make sure everyone stays the minimum safe distance away from the antenna (see illustration on page 1). If no-transmit zones were set up, make sure the customer understands where they are.
- Read the End User Agreement carefully (available at www.kvh.com/mvbcustomercenter).
- Keep the radome installed on the antenna at all times. The radome protects the antenna's moving parts from wind, rain, and debris.
- The antenna must have a clear view of the sky to communicate via satellite. Common causes of blockage include masts, trees, buildings, and bridges (see Figure 74). Dirt buildup on the radome can also affect communications.
- The vessel must be located within the coverage area of the satellite (see www.kvh.com/minivsatmap).
- The system must be activated for mini-VSAT Broadband service (see www.kvh.com/mvbservice).
- Data usage and overage alerts via email and text message, as well as user logins and their associated data allocations, can be configured easily over the Internet at the mini-VSAT Manager (go to www.mykvh.com).

For More Information

Refer to the Help provided on the web interface's Support page (see Figure 75). The Condensed version is text only and resides on the ICM. The Extended version includes images and resides on the KVH website (airtime charges may apply).

NOTE: The Help is compatible with Mozilla Firefox, Internet Explorer, Google Chrome, and Apple Safari.

Figure 73: Customer Welcome Kit



Figure 74: Example of Satellite Blockage

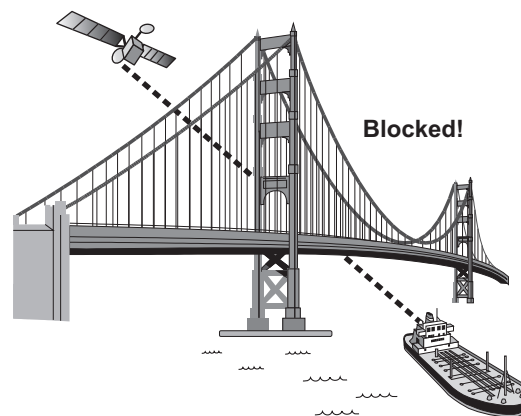
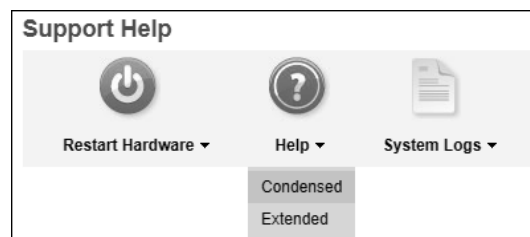

Figure 75: Help Options on Support Page



A

Continued Full Commissioning Steps

Appendix

- c. At Step 2, click **Continue without changes** (see Figure 78).

IMPORTANT!

If you need to abort commissioning at any time, select **Exit commissioning mode**.
Cycling power will not revert the ICM to normal operation mode.

- d. At Step 3, enter your latitude and longitude (see Figure 79).

NOTE: Select the direction (North/South, East/West) before entering each value.

- e. Enter the orbital slot (longitude) of the satellite the antenna is tracking.

NOTE: Select the direction (East/West) before entering the value.

- f. Click **Save remote location and continue** (see Figure 79).

Figure 78: Commissioning Process – Step 2

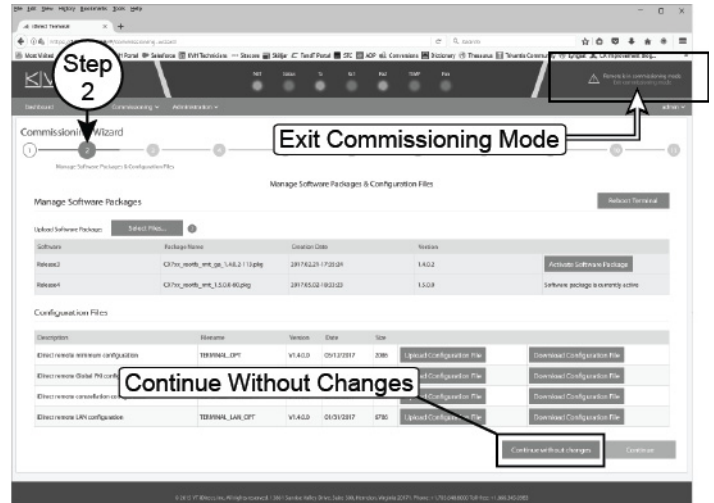
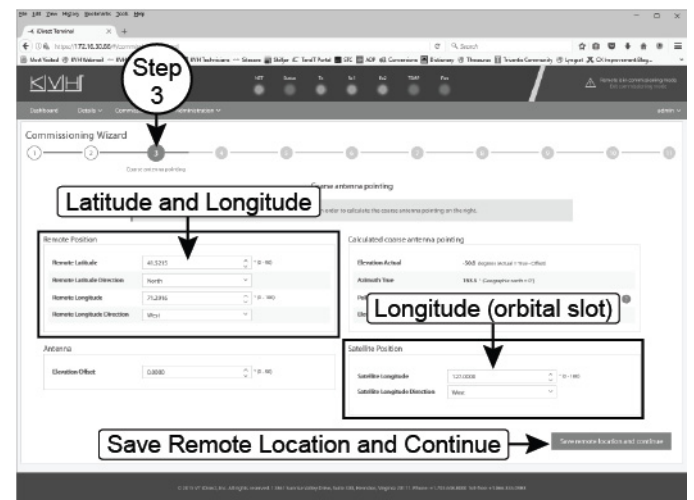

Figure 79: Commissioning Process – Step 3



A

Continued Full Commissioning Steps

Appendix

- g. At Step 4, enter the satellite parameters provided by the NOC (see Figure 80). Verify that the Frequency and the FL Carrier Symbol Rate match the values on the worksheet, and enter zeros for Latitude Variance and Polarization Skew.

When you are done, click **Continue and position antenna** (see Figure 80).

- h. At Step 5, wait until you see the following (see Figure 81):

- Demod Lock Status: Locked
- Antenna Status: Functional, May Transmit

Then click **Stop Antenna pointing**.

Figure 80: Commissioning Process – Step 4

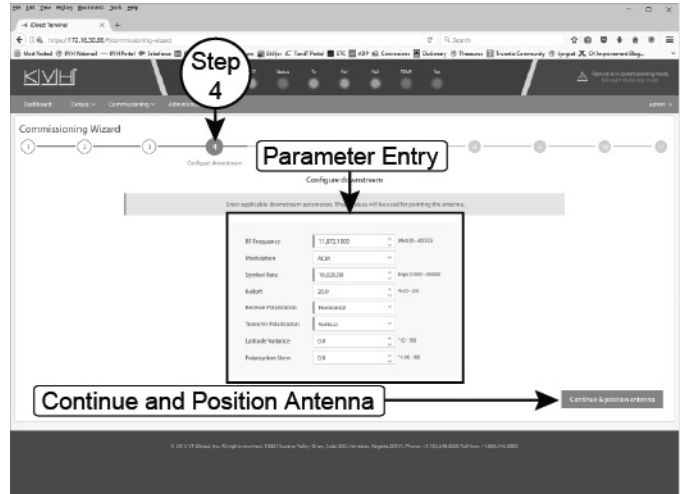
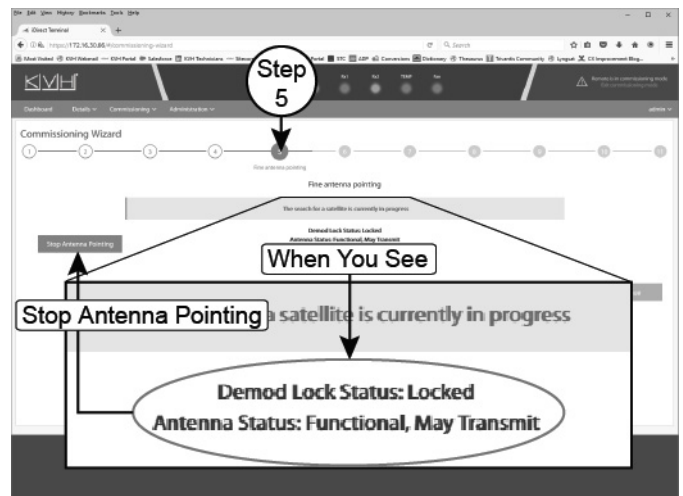

Figure 81: Commissioning Process – Step 5



A Continued Full Commissioning Steps

Appendix

- i. When **Start Antenna Pointing** appears, click **Continue** (see Figure 82).
- j. At Step 6, click **Continue** (see Figure 82).
- k. At Step 7, click **Skip** (see Figure 82).

Figure 82: Commissioning – Steps 5 Through 7

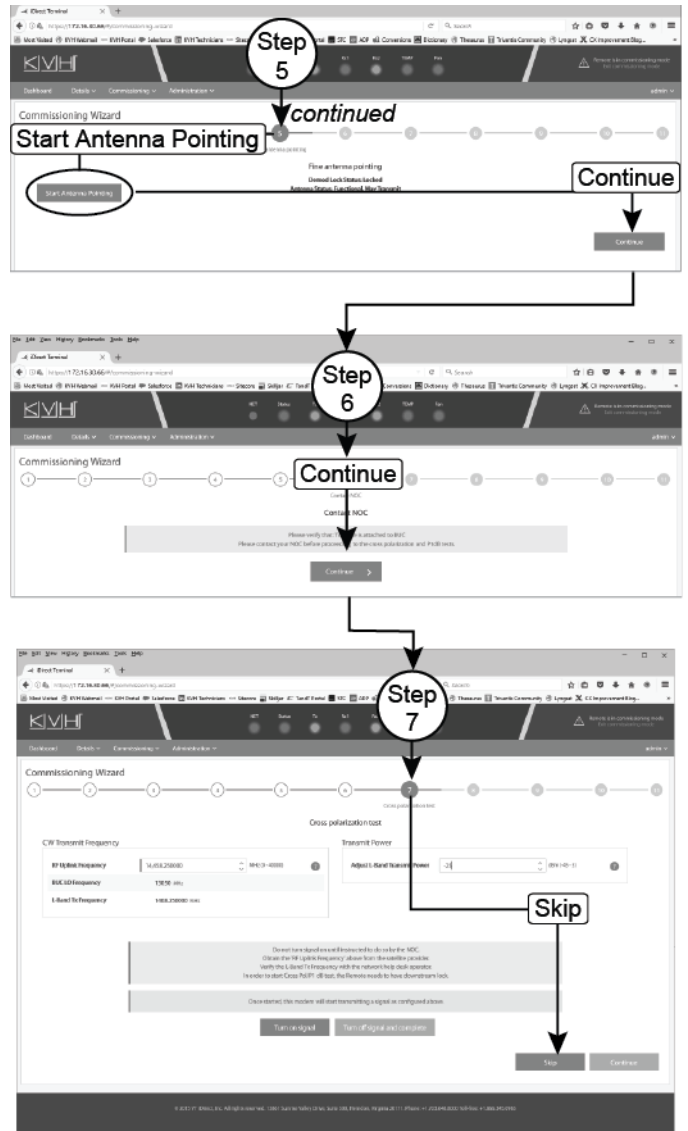

A

Continued Full Commissioning Steps

Appendix

- l. At Step 8, select **CW modulation** and enter the **RF Uplink Frequency** and the initial **Transmit power** that the NOC provided (see Figure 83). Then click **Turn on signal**.
 - m. Continue by using **Adjust L-Band Transmit Power** to adjust the power in 1 dB increments as directed by the NOC and selecting **Apply changes** after each increment (see Figure 84). When directed, click **Turn off signal and complete**.
- NOTE: Take note of the P1dB compression value that is also provided by the NOC. You will enter this value later.*
- n. Next, select **BPSK modulation** and enter the **RF uplink frequency** and the **Starting transmit power** (see Figure 85) provided by the NOC. Then click **Turn on signal**.

Figure 83: Commissioning – Step 8: CW Modulation

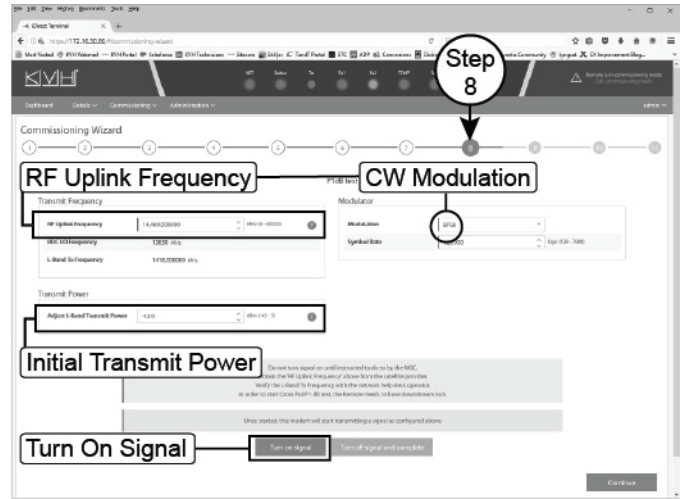

Figure 84: Commissioning – Step 8: CW Modulation continued

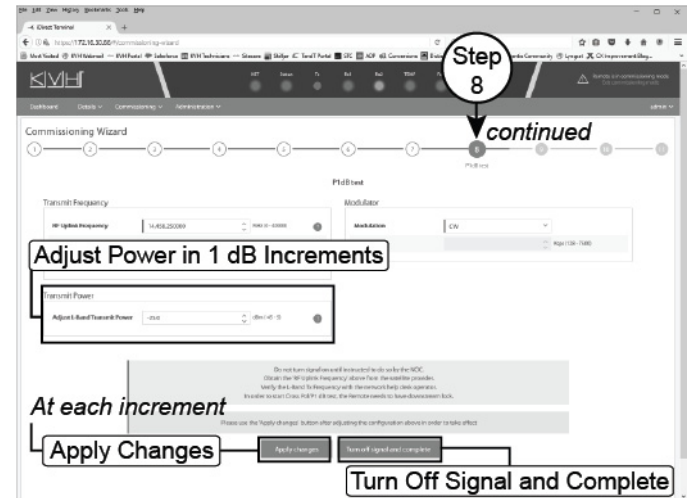
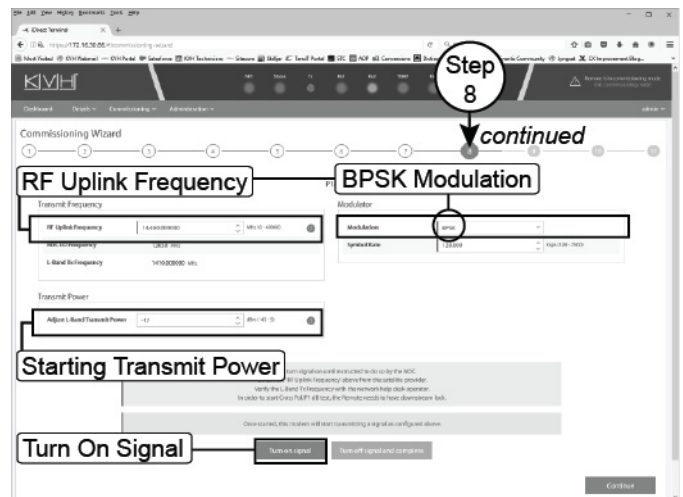

Figure 85: Commissioning – Step 8: BPSK Modulation



A Continued Full Commissioning Steps

Appendix

- o. Continue by using **Adjust L-Band Transmit Power** to adjust the power in 1 dB increments as directed by the NOC and selecting **Apply changes** after each increment (see Figure 86). When directed, click **Turn off signal and complete**.

NOTE: Take note of the Maximum transmit (TX) power value provided by the NOC.

- p. At Step 9, enter the **P1dB** compression value and the **Maximum transmit (TX) power** value provided by the NOC.

IMPORTANT!

Double-check your entries for the P1dB and Maximum TX Power. Maximum TX Power should **always** be one decibel less than the P1dB value. (For example, if P1dB = -15.0 dB then Max TX power = -16.0 dB.)

Then click **Continue** (see Figure 87)

- q. At Step 10, click **Exit commissioning mode** (see Figure 88).
- r. At Step 11, click **Return to dashboard** (see Figure 88).

Close the modem commissioning wizard.
Commissioning is complete!

Figure 86: Commissioning – Step 8: BPSK Modulation *continued*

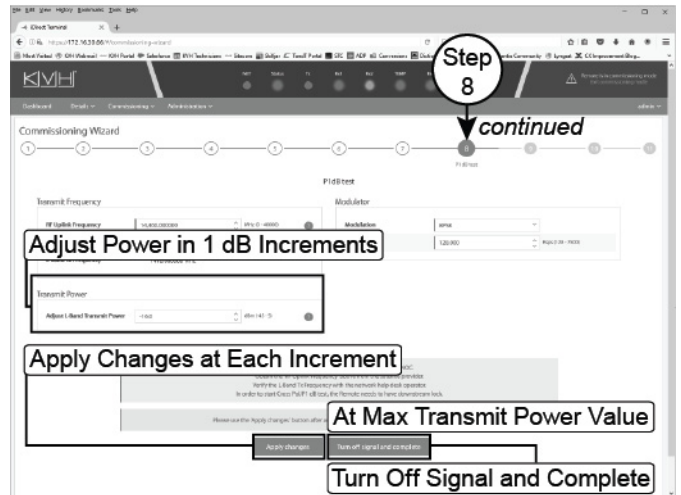

Figure 87: Commissioning – Step 9

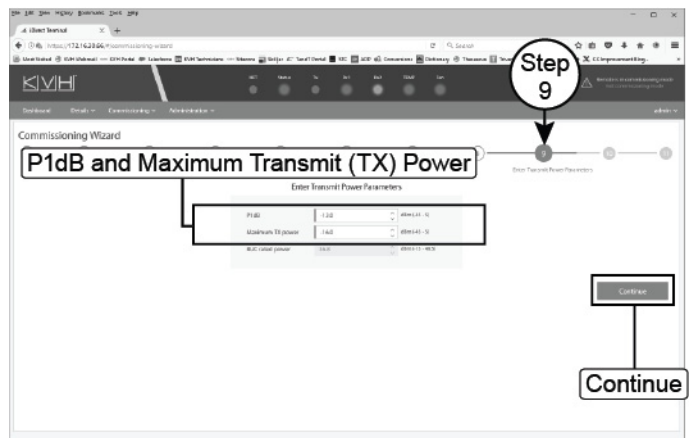
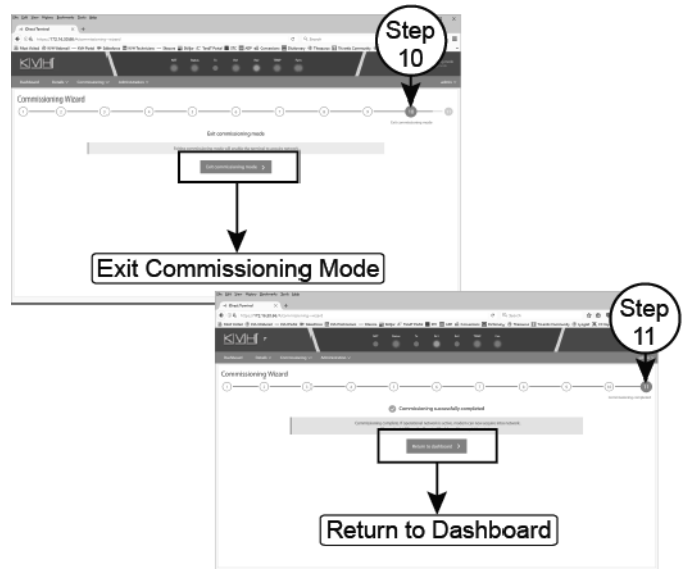

Figure 88: Commissioning – Steps 10 and 11



B Terminating LMR RF Cables

Appendix

These instructions explain how to terminate an LMR-400-75 RF cable with an EZ-400-FMH-75 “F” connector using the tools from the TK-400EZ-75 tool kit. The same steps also apply to an LMR-600-75 cable, with the exception of the tools used.

For more detailed instructions, refer to the Times Microwave website: www.timesmicrowave.com.

1. Using the CCT-01 cutting tool, cut the cable evenly (see Figure 89).
2. Since cutting the cable can deform the end, gently round the end of the cable using a pair of needle-nose pliers (see Figure 90). Also make sure the center conductor is centered within the cable.
3. Place the heat shrink sleeve and metal ferrule onto the cable (see Figure 91).
4. Insert the end of the cable into the #1 end of the ST-400EZ stripping tool (see Figure 92). Then rotate the tool clockwise around the cable until the tool turns easily. The end of the cable should now be stripped to expose the center conductor.

Figure 89: Cutting the Cable



Figure 90: Reshaping the Cable

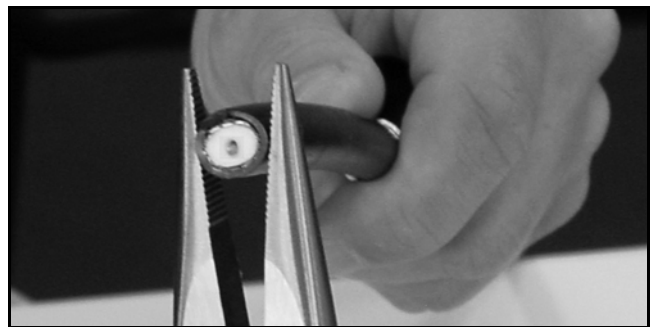
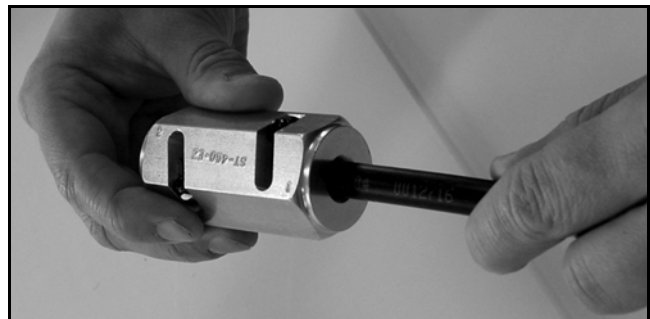

Figure 91: Placing the Heat Shrink Sleeve and Ferrule



Figure 92: Stripping the End to Expose the Center Conductor



B Continued Terminating LMR RF Cables

Appendix

5. Using a utility knife, carefully remove any residual plastic from the center conductor, if necessary (see Figure 93).
6. Insert the end of the cable into the #2 end of the ST-400EZ stripping tool (see Figure 94). Then rotate the tool clockwise around the cable until the tool turns easily. This removes the cable jacket from the end of the cable, exposing the braid and dielectric (see Figure 95).
7. Using the DBT-02 tool, deburr and chamfer the center conductor (see Figure 96). Avoid nicking the aluminum tape covering the dielectric.

Figure 93: Removing Plastic Residue

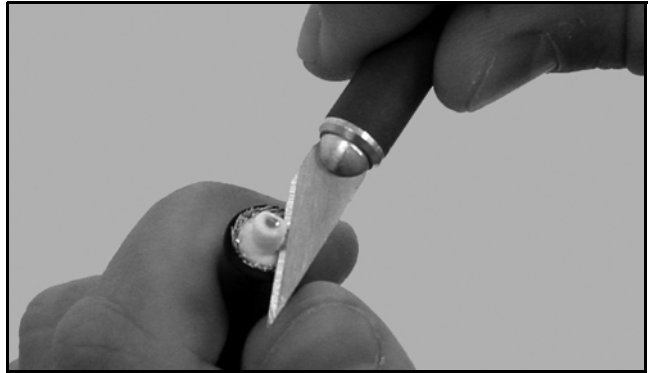

Figure 94: Stripping the Cable Jacket

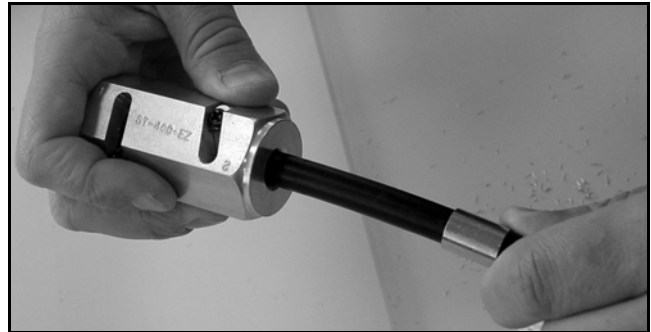

Figure 95: Cable Stripped, Exposing Dielectric



Figure 96: Deburring the Center Conductor



B Continued Terminating LMR RF Cables

Appendix

8. Gently flare the braid with your fingers (see Figure 97).
9. Insert the end of the cable into the connector body until the dielectric is firmly seated inside the connector (see Figure 98). Make sure there is no gap between the knurled end of the connector and the cable jacket. Also be sure all braid wires remain on the outside of the connector.

IMPORTANT!

A common installation failure occurs when the connector is not seated properly onto the cable. In these cases, the cable's center conductor does not fully engage the electrical contacts inside the connector. To ensure full engagement, make certain that there is no gap between the cable jacket and the knurled end of the connector before you crimp on the ferrule. You may need to deburr and center the end of the conductor to achieve a good fit.

10. Trim any excess braid (see Figure 99), if necessary. The braid should assemble flush to within 1/16" (1.6 mm) of the connector shoulder.
11. Slide the ferrule over the braid until it is flush against the connector shoulder (see Figure 100).

Figure 97: Flaring the Braid



Figure 98: Pushing On the Connector

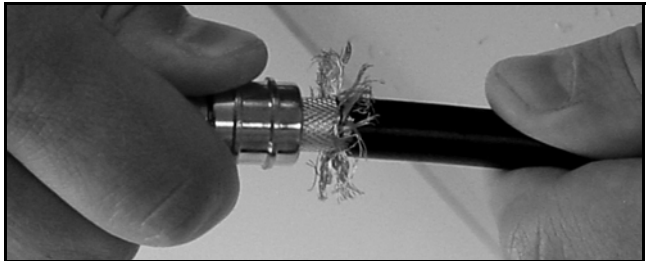

Figure 99: Trimming the Braid

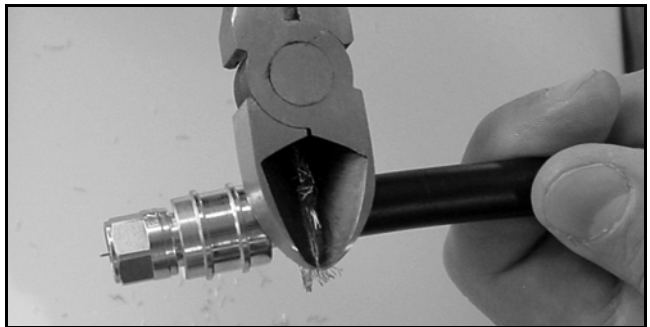
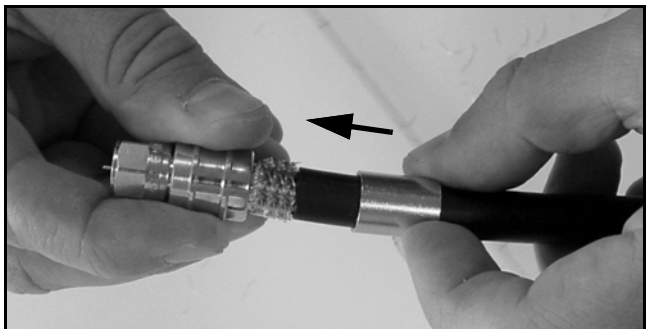

Figure 100: Sliding the Ferrule Over the Braid



B Continued Terminating LMR RF Cables

Appendix

12. Using an appropriate crimp tool (either the CT-400/300 or the HX-4 with Y1719 dies), crimp the ferrule in place (see Figure 101). Crimp as close to the connector body as possible.
13. Crimp the ferrule again, but farther back from the connector. However, be careful not to crimp the cable jacket.
14. Slide the heat shrink sleeve over the connector body and heat it to compress it into place (see Figure 102). When you are done, the heat shrink should extend from the rear of the connector to the cable jacket. This forms a weather-tight seal.
15. Using a multimeter or similar device, check the continuity of the cable.
16. Ensure the center conductor pin measures between 0.20" and 0.28" (5-7 mm) in length, to ensure proper engagement with the mating connector (see Figure 103).

Figure 101: Crimping the Ferrule onto the Cable

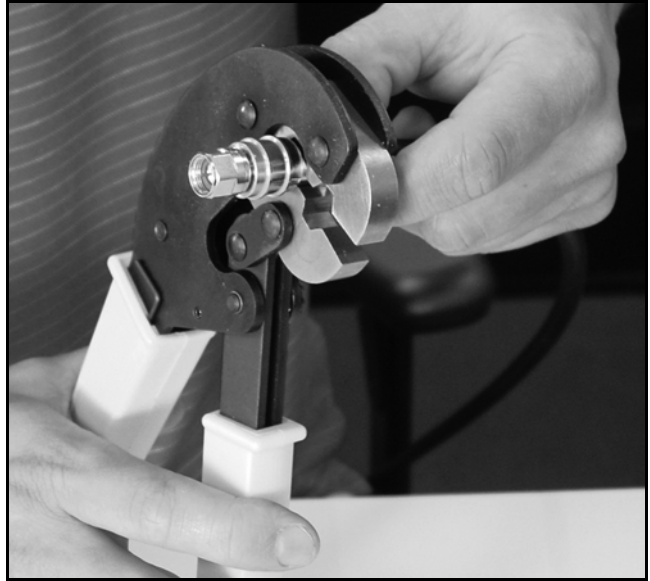

Figure 102: Applying the Heat Shrink Sleeve

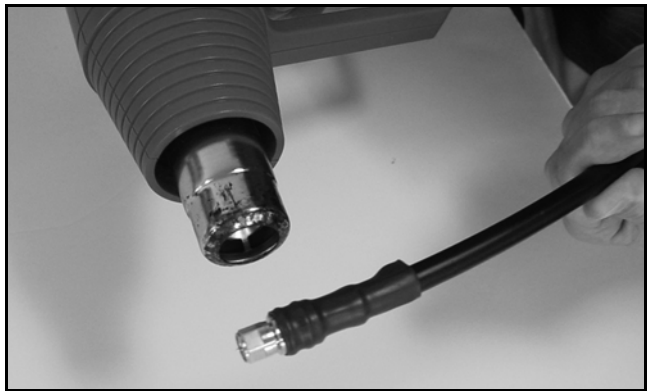
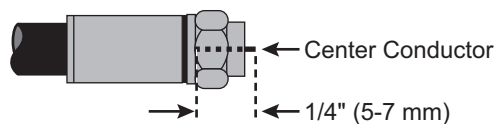

Figure 103: Proper Center Conductor Pin Length



C

Configuring Computers for DHCP

Appendix

Follow these steps to configure your computer for DHCP to allow it to receive an IP address from the ICM. The location of this configuration setting varies slightly by operating system.

NOTE: The computer must have a network interface card installed and all cabling must be 100 Mbps fast Ethernet UTP CAT-5 with RJ45 connectors.

Windows 10

1. Turn on the computer.
2. Open the **Network and Sharing Center**. The easiest way to get there is to simply enter the name in the search box on the taskbar. You can also navigate to it from the Start menu: *Settings > Network & Internet > Ethernet > Network and Sharing Center*.
3. In the Network and Sharing Center, click the **Ethernet** link for the Ethernet connection you are using.
4. In the Ethernet Status dialog box, click **Properties**. *If this screen doesn't appear, skip to Step 5.*
5. In the Ethernet Properties dialog box, on the **Networking** tab, select **Internet Protocol Version 4**, and then click **Properties**.
6. In the Internet Protocol Properties dialog box, select **Obtain an IP address automatically** and **Obtain DNS server address automatically** (see Figure 104). Then click **OK**.
7. In the Ethernet Properties dialog box, click **Close**. Then click **Close** in the Ethernet Status dialog box.

Figure 104: Windows 10 - Internet Protocol Properties

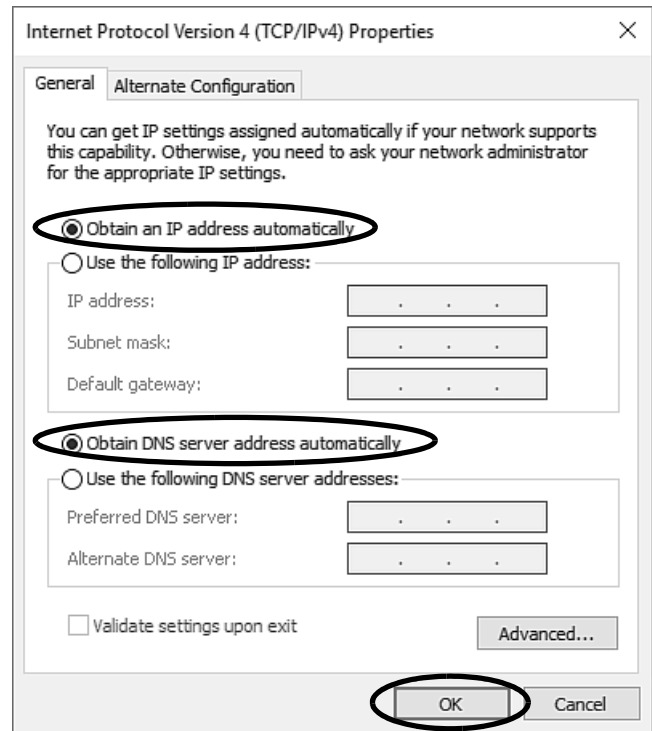

Windows 8

1. Turn on the computer.
2. In Control Panel, double-click **Network and Sharing Center**. *To open the Control Panel, go to the desktop, select Settings from the Charms bar, then select Control Panel.*
3. In Network and Sharing Center, double-click the **Ethernet** link for the Ethernet connection you are using.
4. In the Ethernet Status dialog box, click **Properties**. *If this screen doesn't appear, skip to Step 5.*
5. In the Ethernet Properties dialog box, on the **Networking** tab, select **Internet Protocol Version 4**, and then click **Properties**.
6. In the Internet Protocol Properties dialog box, select **Obtain an IP address automatically** and **Obtain DNS server address automatically** (see Figure 105). Then click **OK**.
7. In the Ethernet Properties dialog box, click **Close**.

Figure 105: Windows 8 - Internet Protocol Properties

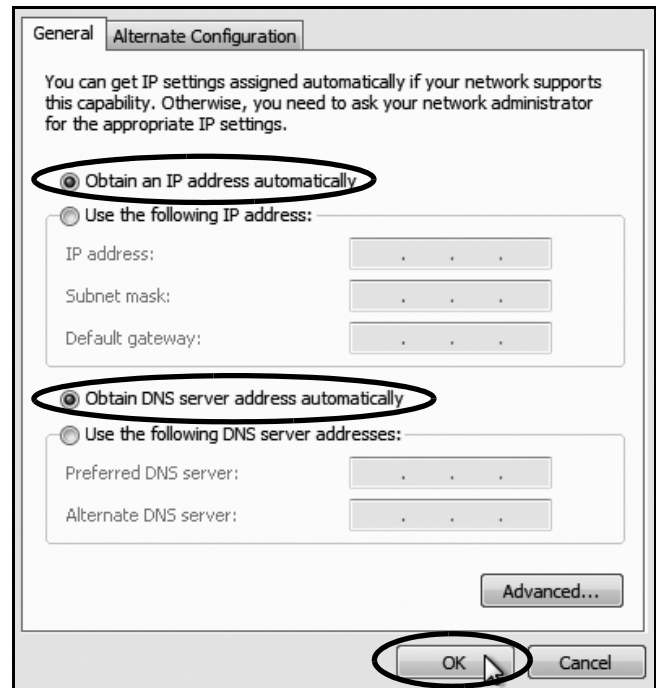

Windows 7 or Windows Vista

1. Turn on the computer.
2. In the Control Panel, double-click **Network and Sharing Center**. (You might need to click **Network and Internet** first.) *You can find the control panel either through the Start menu or "My Computer."*
3. In the Network and Sharing Center, double-click the **Local Area Connection** link (Windows 7) or **View Status** link (Windows Vista) for the Ethernet connection you are using.
4. In the Local Area Connection Status dialog box, click **Properties**. *If this screen doesn't appear, skip to Step 5.*
5. In the Local Area Connection Properties dialog box, click the **Networking** tab, select **Internet Protocol Version 4**, and then click **Properties**.
6. In the Internet Protocol Properties dialog box, select **Obtain an IP address automatically** and **Obtain DNS server address automatically** (see Figure 106). Then click **OK**.
7. In the Local Area Connection Properties dialog box, click **OK**.

Figure 106: Windows 7/Windows Vista- Internet Protocol Properties

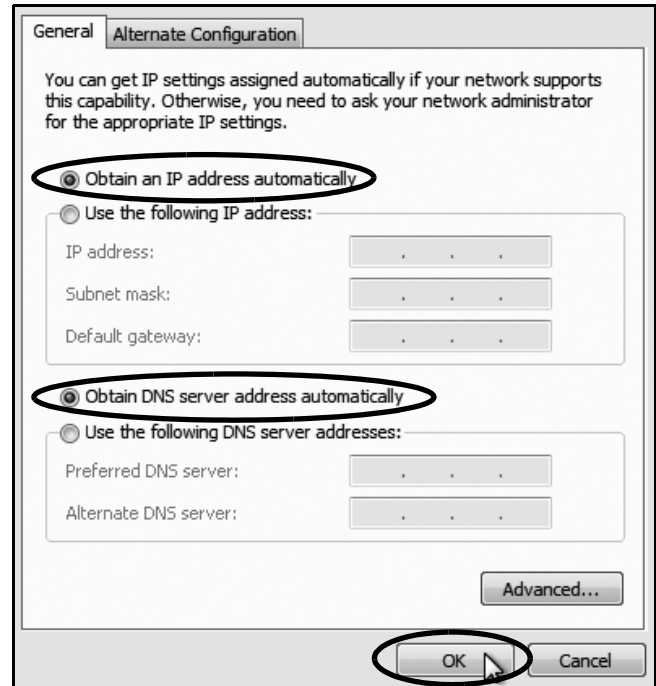

Windows XP

1. Turn on the computer.
2. In the Control Panel, double-click **Network Connections**. *You can find the control panel either through the Start menu or "My Computer."*
3. In the Network Connections, double-click the **Local Area Connection** for the Ethernet connection you are using.
4. In the Local Area Connection Status dialog box, click the **General** tab. Then click **Properties**. *If this screen doesn't appear, just skip to Step 5.*
5. In the Local Area Connection Properties dialog box, click the **General** tab, select **Internet Protocol (TCP/IP)**, and then click **Properties**.
6. In the Internet Protocol (TCP/IP) Properties dialog box, click the **General** tab. Then select **Obtain an IP address automatically** and **Obtain DNS server address automatically** (see Figure 107). Then click **OK**.
7. In the Local Area Connection Properties dialog box, click **OK**.
8. Restart the computer.

Figure 107: Windows XP - Internet Protocol (TCP/IP) Properties

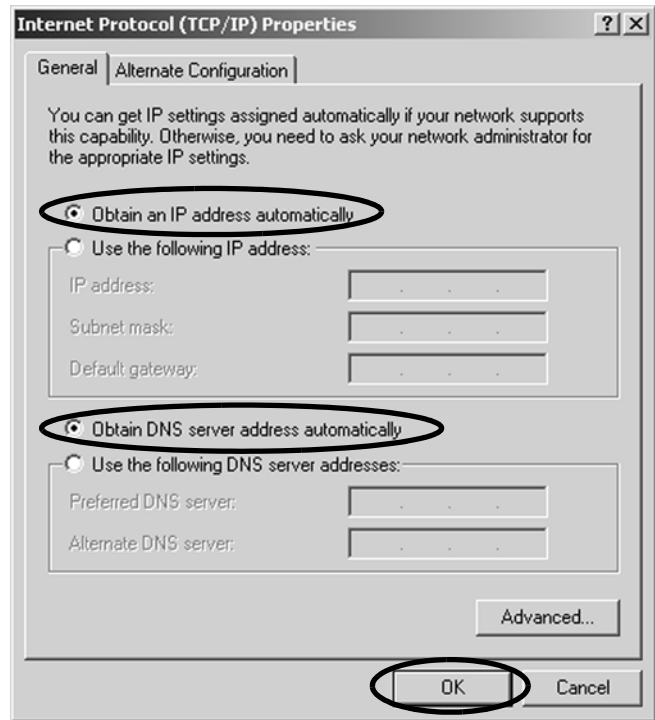

C

Continued Configuring Computers for DHCP

Appendix

Macintosh OS X

1. Turn on the computer.
2. In System Preferences, click **Network**.
3. In the Network dialog box, select **Ethernet** then set the following:
 - Location: **Automatic**
 - Configure IPv4: **Using DHCP**
4. Click **Apply**.
5. Restart the computer.

Figure 108: Macintosh OS X - Network Preferences

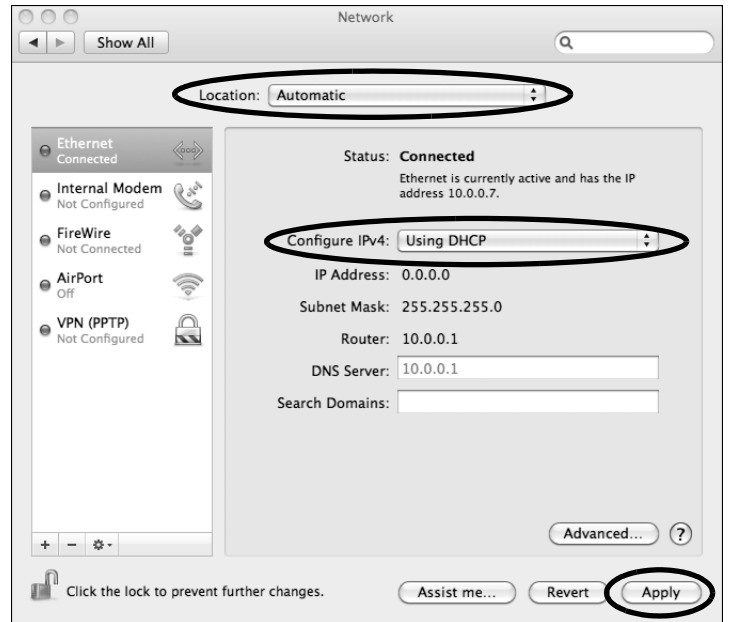

D Wiring Diagram

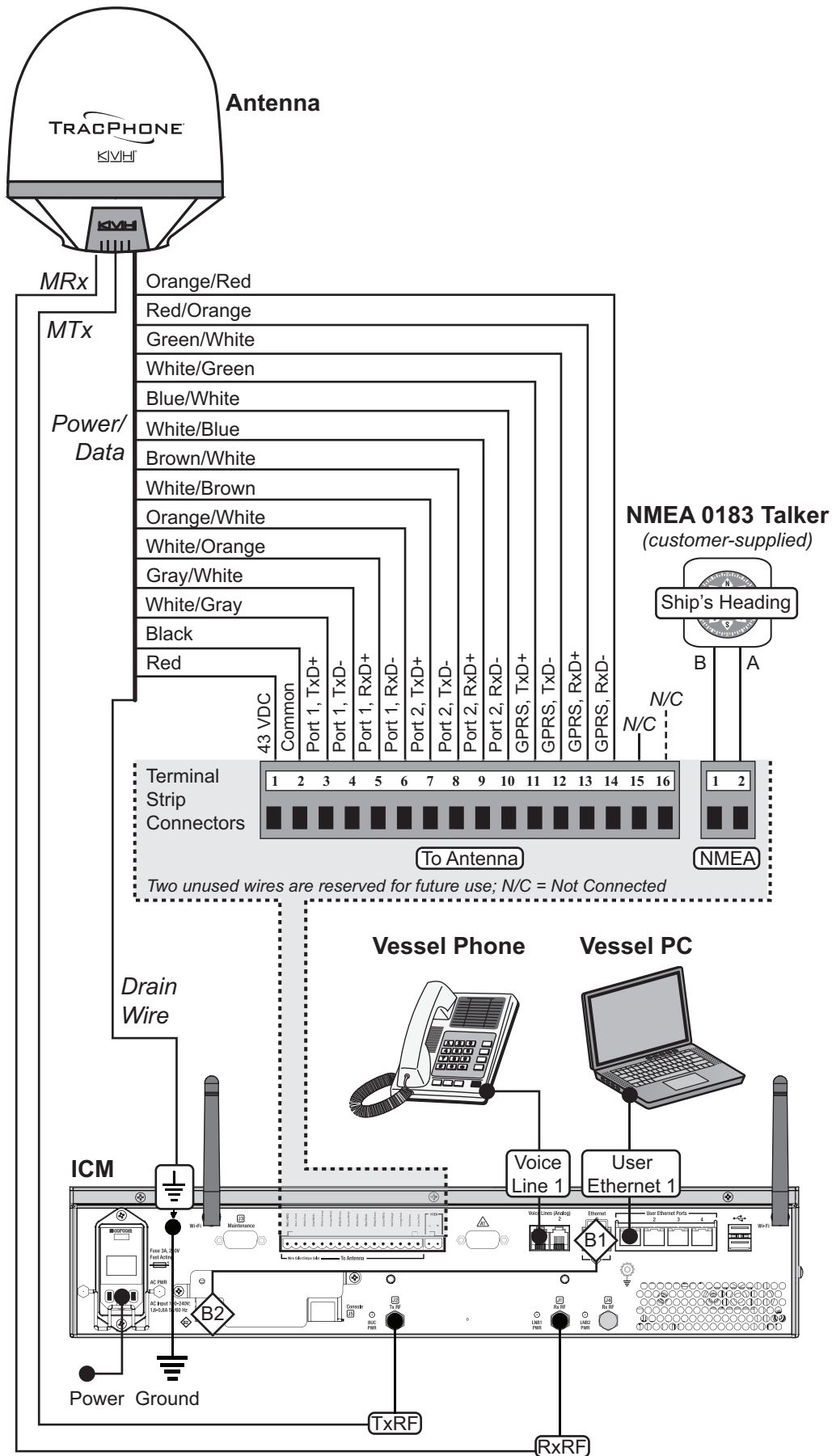



Regulatory Compliance

European Union Compliance

Hereby, KVH Industries, Inc. declares that the radio equipment type TracPhone V7-HTS is in compliance with Directive 2014/53/EU. For the full text of the EU Declaration of Conformity, go to www.kvh.com/euconformity.

Federal Communications Commission Compliance



The TracPhone system complies with Class B of Part 15 of the FCC (Federal Communications Commission) rules for radiated and conducted emissions.

FCC Identifiers: QIP-EHS6 (antenna 3G Modem)
PPD-AR5B97 (ICM WiFi)

Use Conditions:

This device complies with part 15 of the FCC Rules. Operation is subject to the following two conditions:

1. This device may not cause harmful interference.
2. This device must accept any interference received, including interference that may cause undesired operation.

Note:

This equipment has been tested and found to comply with the limits for a Class B digital device, pursuant to Part 15 of the FCC Rules. These limits are designed to provide reasonable protection against harmful interference in a residential installation. This equipment generates, uses, and can radiate radio frequency energy and, if not installed and used in accordance with the instructions, may cause harmful interference to radio communications. However, there is no guarantee that interference will not occur in a particular installation. To determine if the equipment is interfering with radio or television reception, remove or apply power to the equipment and observe if the interference goes away, or returns, when the unit is off or on. The user is encouraged to try to correct the interference by one of the following measures:

- Reorient or relocate the receiving antenna.
- Increase the separation between the equipment and receiver.
- Connect the equipment into an outlet on a circuit different from that to which the receiver is connected.
- Consult KVH for assistance.

IMPORTANT:

- To meet FCC requirements, shielded Ethernet cables are required to connect the ICM to the ship's network.
- This equipment contains no user serviceable parts. Opening this unit will violate the warranty and may result in this equipment no longer complying with FCC requirements for Class B digital devices.

CE

**UK
CA**



www.kvh.com



KVH Industries A/S
EMEA Headquarters
Birkerød, Denmark
Tel: +45.45.160.180 Fax: +45.45.160.181
Email: info@emea.kvh.com

KVH Industries, Inc.
World Headquarters
Bristol, RI U.S.A.
Tel: +1.401.847.3327 Fax: +1.401.849.0045
Email: info@kvh.com

KVH Industries Pte Ltd.
Asia-Pacific Headquarters
Singapore
Tel: +65.6513.0290 Fax: +65.6472.3469
Email: info@apac.kvh.com