

**KVH Industries, Inc.**

# TracPhone® V3<sub>HTS</sub>



**Installation Guide**

# TracPhone V3-HTS Installation Guide

## mini-VSAT Broadband<sup>SM</sup> System with Integrated CommBox<sup>TM</sup> Modem

This guide explains how to install the TracPhone V3-HTS mini-VSAT Broadband satellite communications system. Operation instructions are provided in the Quick Start Guide.

### Installation Steps

1. Inspect Parts and Get Tools .....	3	11. Connect Power .....	18
2. Plan the Antenna Installation .....	4	12. Turn On the System .....	20
3. Plan the ICM Installation.....	7	13. Update the System Software.....	21
4. Mount the ICM .....	8	14. Customize the Web Interface.....	22
5. Prepare the Antenna Site.....	9	15. Set Up No-Transmit Zones .....	23
6. Remove the Shipping Restraints .....	10	16. Commission the Modem .....	24
7. Prepare the Antenna Cables .....	11	17. Test the System .....	25
8. Wire the Antenna .....	13	18. Configure the Network .....	26
9. Mount the Antenna .....	14	19. Connect Voice Line Equipment.....	31
10. Wire the ICM.....	15	20. Educate the Customer.....	32

### CAUTION - RF Radiation Hazard



The antenna transmits radio frequency (RF) energy that is potentially harmful. Whenever the system is powered on, make sure everyone stays more than 32 ft (10 m) away from the antenna within its 7.7-75° elevation range. No hazard exists directly above the antenna and anywhere below the antenna's mounting plane.

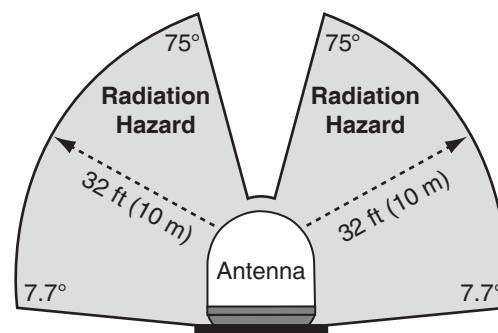

### Who Should Install the System?

To ensure a safe and effective installation, only a KVH-certified technician should install the TracPhone system. To find a technician near you, visit [www.kvh.com/wheretogetservice](http://www.kvh.com/wheretogetservice).

### Technical Support

**North/South America, Australasia:**  
Phone: 1 866 701-7103 (*U.S. only*)  
Phone: +1 401 851-3806  
Email: [mvbsupport@kvh.com](mailto:mvbsupport@kvh.com)

**Europe, Middle East, Africa, Asia-Pacific:**  
Phone: +45 45 160 180  
Email: [mvbsupport@kvh.com](mailto:mvbsupport@kvh.com)

# Important Safety Information

---



This icon indicates a danger, warning, or caution notice. Be sure to read these carefully to avoid injury.



## **WARNING**

### **Risk of Electric Shock**

Potentially lethal voltages are present within the ICM when it is connected to AC power. To avoid electric shock, do not open the chassis enclosure. There are no user-serviceable parts inside.



## **WARNING**

### **Risk of Electric Shock**

If any component of the TracPhone system becomes damaged and/or no longer functions normally, disconnect it from vessel power, secure it from unintended operation, and contact KVH Technical Support (see “Technical Support” on page 1). All repairs or modifications must be performed by a trained, KVH-certified technician. If you are a KVH-certified technician, you still must contact KVH Technical Support prior to conducting any repairs or modifications to the equipment.



## **WARNING**

### **Risk of Explosion**

Do not operate the ICM (or any other electrical device) in an environment where flammable gases, vapors, or dusts are present. In addition, do not operate the ICM in an environment with a temperature outside its 5° F to 131° F (-15° C to 55° C) temperature range.



## **WARNING**

### **Risk of Electric Shock**

Failure to ground the TracPhone system properly to ship’s ground will cause an unsafe floating ground condition, risking potentially lethal electric shock. See “Connect Power” on page 18 for details on the proper grounding of the equipment.



## **CAUTION**

### **RF Radiation Hazard**

The antenna transmits up to 4 watts of radio frequency (RF) energy that is potentially harmful. Whenever the system is powered on, make sure everyone stays more than 32 feet (10 m) away from the antenna. No hazard exists directly below the antenna.

# 1 Inspect Parts and Get Tools

Before you begin, follow these steps to make sure you have everything you need to complete the installation.

- a. Unpack the box and ensure it contains everything shown in Figure 1 and on the *Kitpack Contents List*. Save the packaging for future use.

**IMPORTANT!**

Always lift the antenna by the baseplate and never by the radome or any portion of the internal antenna assembly (see Figure 1).

- b. Carefully examine all of the supplied parts to ensure nothing was damaged in shipment.
- c. Gather all of the following tools and materials that you will need:
  - Flat-head and Phillips-head screwdrivers
  - Electric drill and 5/16" (8 mm) bit
  - 3.5" (89 mm) hole saw
  - 1/2" socket and 7/16" socket
  - 7/16" open-end torque wrench set to 20 in.-lbs
  - Light hammer and center punch
  - Adhesive tape
  - Silicone sealant, self-vulcanizing tape, or equivalent
  - Eye protection
  - Shop towels
  - Voltmeter
  - Utility knife
  - Flush cutters
  - Wire stripper/terminal crimper
  - File
  - Two 75Ω RF coax cables, "F" connectors, and associated termination tools (see page 11)

Figure 1: TracPhone V3-HTS System Components

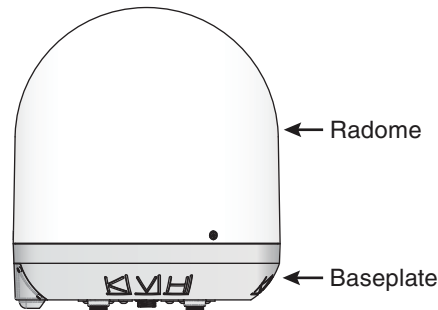

**Antenna**  
(KVH part no. 02-1860-01)

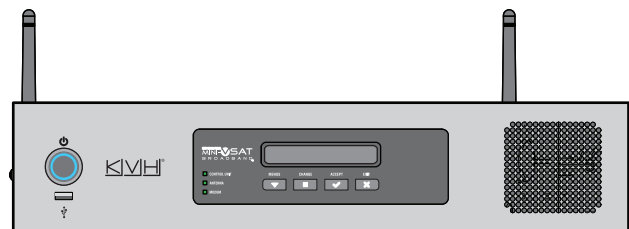

**Integrated CommBox Modem (ICM)**  
(KVH part no. 02-2204-01)

- NMEA 0183 talker and interface cable (see page 16)
- Isolation transformer, if required (see page 18)
- RS422-to-USB adapter
- Laptop PC with the latest TracPhone V3-HTS ICM/antenna software downloaded from the KVH Partner Portal ([www.kvh.com/partners](http://www.kvh.com/partners))

# 2 Plan the Antenna Installation

Before you begin, consider the following antenna installation guidelines.

## Choose a Suitable Location

- Select a location that is as close as possible to the intersection of the vessel's centerline and midships.
- Temperature must be within the operating range (-25°C to 55°C (-13°F to 131°F)).
- Avoid placing the antenna near any magnetic compasses or other onboard antennas to prevent potential interference.

## Meet Mounting Structure Guidelines

Make sure the mounting surface is flat, level (within  $\pm 2^\circ$ ), and wide enough to accommodate the antenna's base (see Figure 2). Also make sure its mounting structure is strong enough to withstand the weight of the antenna (25 lbs, 11.3 kg), as well as other cumulative forces related to expected operating conditions, such as ice, snow, wash down, and maximum expected values of pitch, roll, and wind pressure (including gusts).

Vibration of the mounting surface should measure less than 0.51 gRMS total, and also less than 0.11 gRMS at the following resonant frequencies and axes:

- 22.6 Hz and 41.0 Hz in Horizontal Forward X-Direction
- 23.5 Hz and 43.6 Hz in Horizontal Side Y-Direction
- 27.4 Hz and 45.0 Hz in Vertical Z-Direction

Please consult with your shipyard to ensure that the antenna mounting surface vibration never exceeds the above stated conditions at any time during its life.

Figure 2: Antenna Dimensions

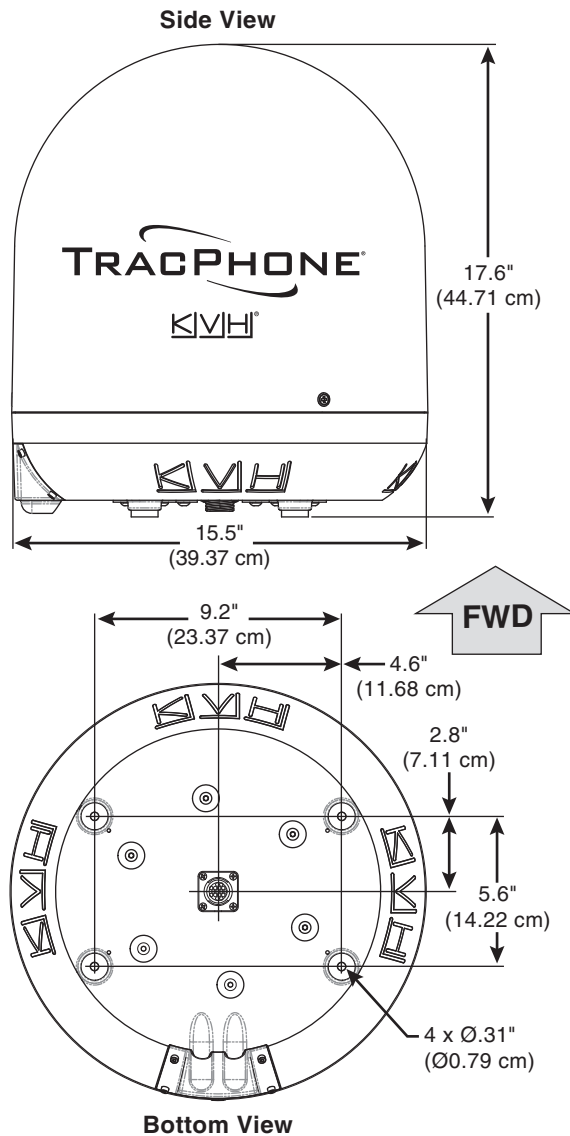

# 2 Continued Plan the Antenna Installation

## Meet Pedestal Structure Requirements

If a pedestal is going to be used, it must meet the following minimum requirements. Refer to Figure 3.

Figure 3: Pedestal and Brace Dimensions

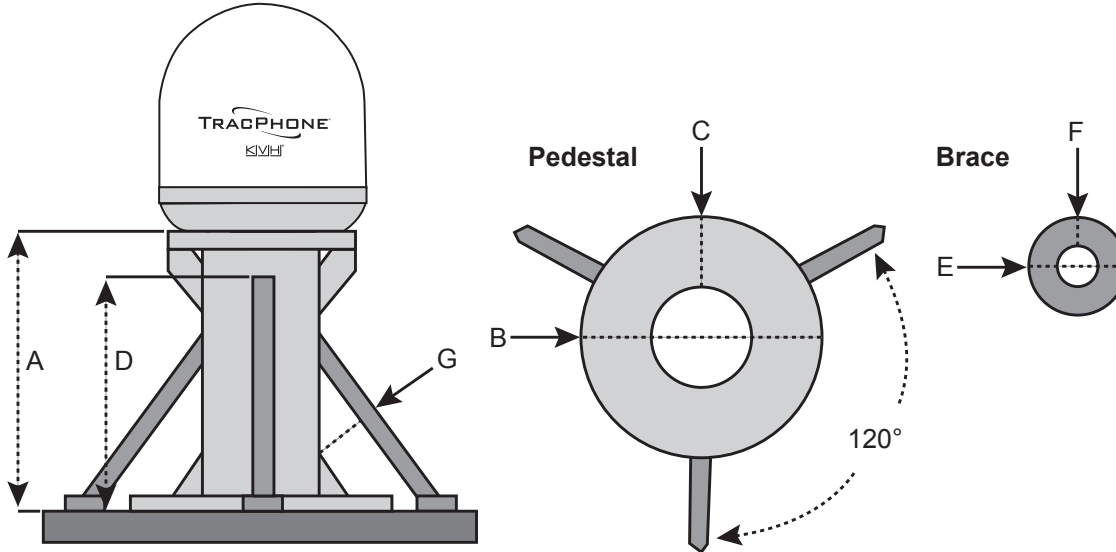

<b>Pedestal Height (A)</b>	3.28 ft (1 m)	6.56 ft (2 m)	9.84 ft (3 m)	13.12 ft (4 m)
<b>Tube OD (B)</b>	5.0" (127 mm)	3.0" (76.2 mm)	5.0" (127 mm)	8.0" (203.2 mm)
<b>Tube Wall Thickness (C)</b>	0.25" (6.35 mm)			0.5" (12.7 mm)
<b>Brace Height (D)</b>	N/A	5.25 ft (1.60 m)	7.35 ft (2.24 m)	9.12 ft (2.78 m)
<b>Brace OD (E)</b>	N/A	2.25" (57.15 mm)	4.5" 114.3 mm	7.0" (177.8 mm)
<b>Brace Thickness (F)</b>	N/A	0.25" (6.35 mm)		
<b>Brace Angle(G)</b>	N/A	25°		

**NOTE:** If the pedestal exceeds 3.28 ft (1 m), braces must be placed at 120° intervals. Sizing is based on Structural Steel Tubing 60,000 psi (415 MPa) minimum yield.

# 2 Continued Plan the Antenna Installation

## Prevent RF Radiation Exposure

Select a location that is well above any areas accessible to passengers and crew to reduce the risk of RF radiation exposure. (See page 1 for an illustration of the hazard area.)

If mounting the antenna near an accessible area is unavoidable, you may configure one or two no-transmit zones to prevent transmissions in hazardous directions. (See “Set Up No-Transmit Zones” on page 23 for details.)

## Minimize Satellite Blockage

The antenna requires a clear view of the sky to transmit and receive satellite signals (see Figure 4). The fewer obstructions, the better the system will perform.

## Avoid RF Interference

Although many variables determine the exact distance required between the antenna and radar/high-power radio transmitters, including transmitter beam properties and the reflective properties of nearby surfaces, consider the following general guidelines when selecting a safe antenna location:

### IMPORTANT!

RF emissions from radars and high-power radio transmitters may damage the antenna or impair its performance if it's improperly positioned within the beam path.

- Mount the antenna as far away as possible from the radar and high-power radio transmitters.
- Do not mount the antenna at the same level as the radar. Most radar transmitters emit RF energy within an elevation range of  $-15^\circ$  to  $+15^\circ$  (see Figure 5). Therefore, mount the antenna outside this elevation range and at least 10 ft (3 m) away from the transmitter.

### IMPORTANT!

Never place the antenna in the beam path of the radar regardless of distance. Radar energy may damage the antenna or impair its performance.

Figure 4: Blockage from Obstruction

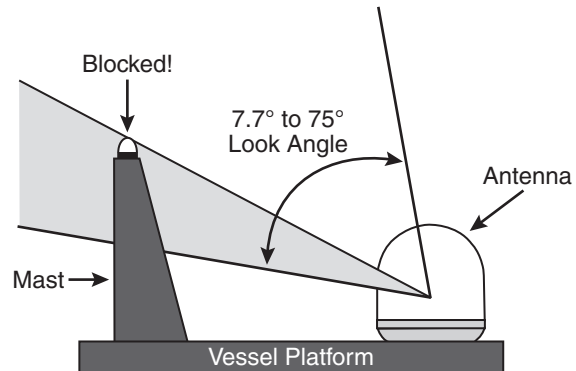
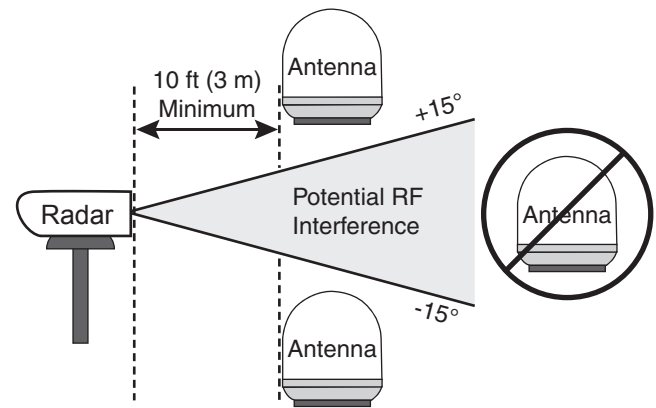

Figure 5: Avoiding RF Interference



# 3 Plan the ICM Installation

Before you begin, consider the following installation guidelines for the ICM.

- Select a mounting location in a dry, well-ventilated area belowdecks away from any heat sources or salt spray.
- Temperature must be within the operating range (-15°C to 55°C (5°F to 131°F)).
- Be sure the front panel will be easily accessible to the user.
- Leave enough room at the rear panel to accommodate the connecting cables.
- To use the supplied power/data cable, the ICM must be located within 100 ft (30 m) of the antenna. However, you can order a longer cable run if necessary.
- Be sure the location provides adequate Wi-Fi reception. Do not install it in an area surrounded by metal or near any electrical devices that emit RF noise.

Figure 6: ICM Dimensions

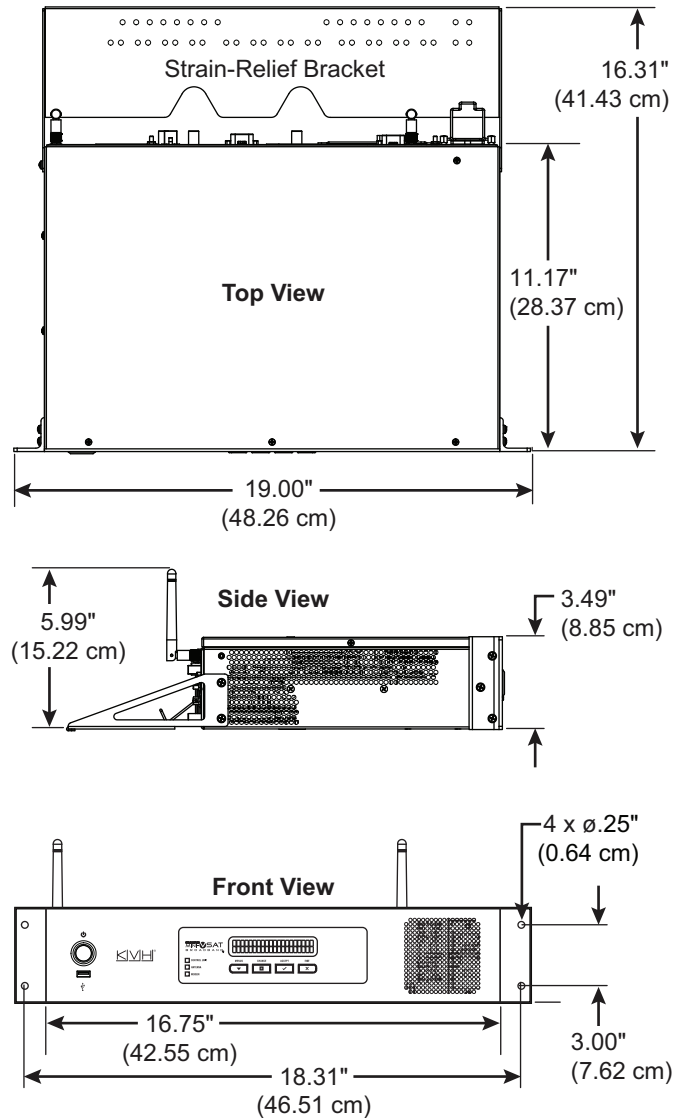

# 4 Mount the ICM

There are two options for mounting the ICM:

- Option 1** - Inside an equipment rack
- Option 2** - To a horizontal surface

*NOTE: You may choose to wait to mount the ICM until after you have completed all system wiring.*

## Option 1 – Rack Mount

The ICM is sized to fit a standard 19" (48.26 cm) rack, occupying 2U of space. Follow these steps to secure the ICM in an equipment rack.

- a. Attach the supplied strain-relief bracket to the back of the ICM using four supplied #6-32 screws and washers (see Figure 7).
- b. Insert the ICM into the rack and secure its front mounting brackets to the rack using four M6 screws and washers (see Figure 8).

## Option 2 – Horizontal Surface Mount

Follow these steps to mount the ICM to a horizontal surface.

- a. Remove the six #6-32 screws and washers securing the two rack-mount brackets to the front of the ICM (see Figure 9). Remove the brackets.
- b. Attach the supplied strain-relief bracket to the back of the ICM, and attach the supplied "L" mounting brackets to the sides of the ICM, using six supplied #6-32 screws and washers (see Figure 10).
- c. Mount the ICM to the vessel using fasteners appropriate for the mounting surface.

Figure 7: Attaching the Strain-Relief Bracket

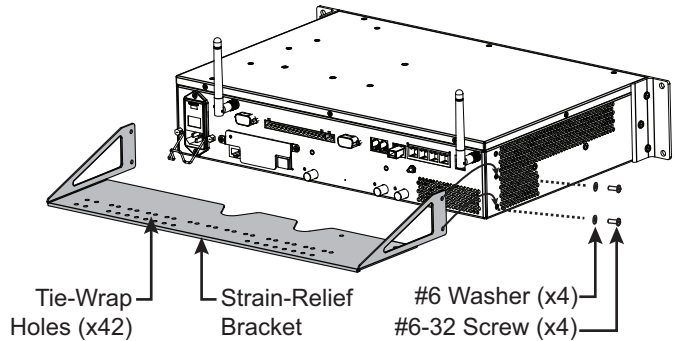

Figure 8: Securing the ICM in the Rack

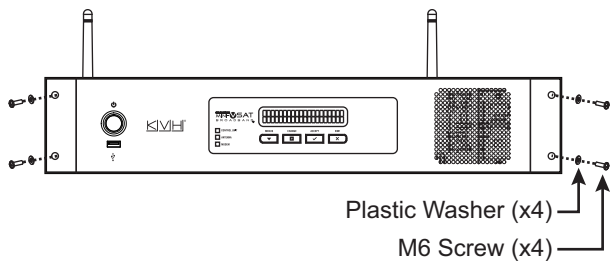

Figure 9: Removing the Rack-Mount Brackets

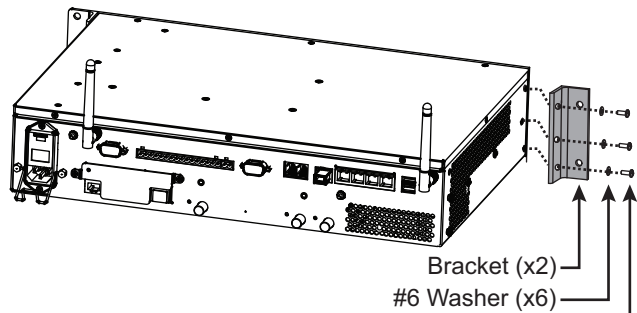
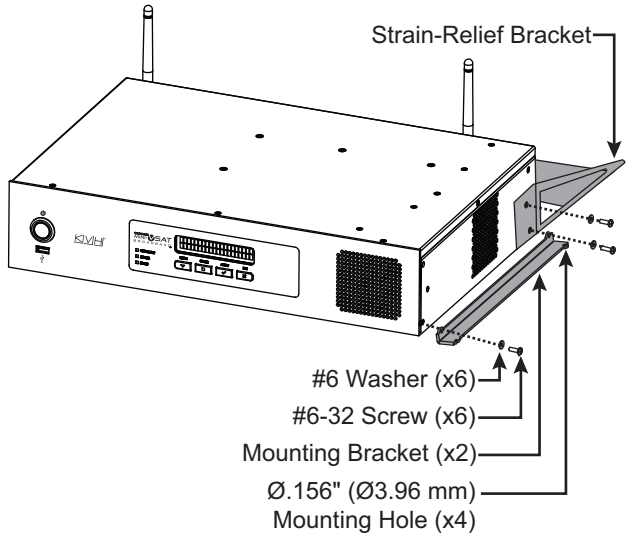

Figure 10: Attaching the Mounting and Strain-Relief Brackets



# 5 Prepare the Antenna Site

Once you have identified a suitable antenna mounting site, according to the guidelines provided in “Plan the Antenna Installation” on page 4, follow these steps to prepare the site for installation.

- a. Unfold the antenna mounting template (supplied in the Customer Welcome Kit) and place it onto the mounting surface. Make sure the “FWD” (forward) arrow points toward the bow and is parallel to the vessel’s centerline (see Figure 11).

**NOTE:** You don’t need to mount the antenna exactly on the vessel’s centerline, but the antenna’s forward arrow must be parallel to it.

- b. Using a light hammer and center punch, mark the locations for the four mounting holes and cable access hole on the mounting surface in the locations indicated on the template.
- c. Drill a 5/16" (8 mm) hole at the four mounting hole locations you marked in Step b. Later, you will insert four 1/4"-20 bolts through these holes to secure the antenna to the mounting surface.
- d. Cut out the 3.5" (89 mm) cable access hole in the location you marked in Step b. Smooth the edges of the hole to protect the cables. (You may also apply anti-chafe material around the cables to prevent abrasion.) Later, you will route the power/data and RF cables through this hole and into the vessel.
- e. Clean and dry the antenna mounting surface.
- f. Peel off the paper backing from the supplied foam seal to expose the adhesive. Then press the foam seal down firmly onto the mounting surface, ensuring the hole in the foam seal aligns with the cable access hole in the mounting surface (see Figure 11).

**NOTE:** Apply the foam seal to the vessel mounting surface, not to the antenna’s baseplate.

- g. Transport the antenna to the mounting site.

Figure 11: Antenna Mounting Holes Layout

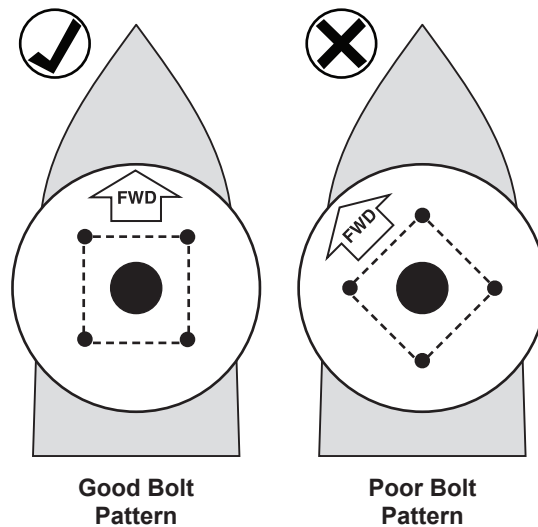
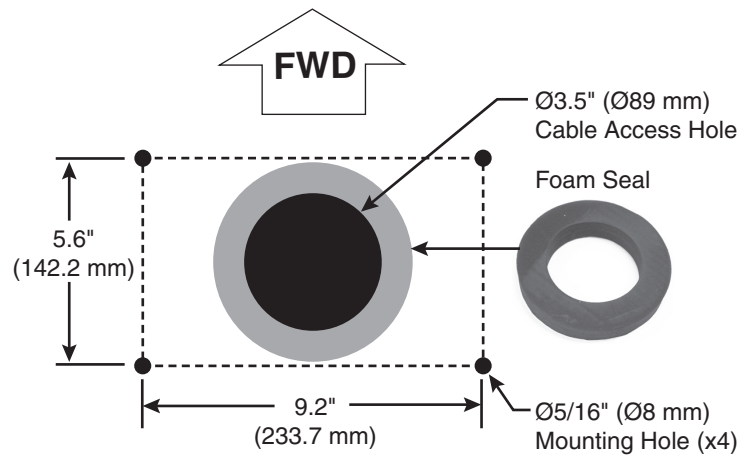

# 6 Remove the Shipping Restraints

Inside the antenna, two shipping restraints prevent the antenna assembly from moving during shipment. Follow these steps to remove these restraints.

- a. Remove the three #10-32 Phillips screws securing the radome to the baseplate (see Figure 12). Carefully lift the radome straight up until clear of the antenna assembly and set it aside in a safe place.

**NOTE:** Due to the snug fit, some contact between the radome's sealing gasket and the antenna mechanism is normal.

- b. Remove the two #10-32 shipping restraint screws (see Figure 13). Save the restraints for future use.

**IMPORTANT!**

Once you have removed the restraints, handle the antenna carefully. With the restraints removed, the internal antenna assembly rotates freely and, if not handled properly, can damage the limit switch.

Figure 12: Removing the Radome

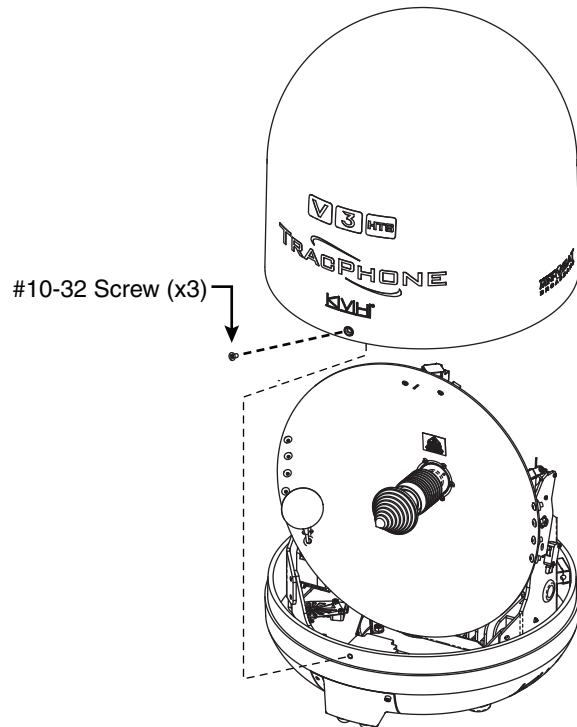
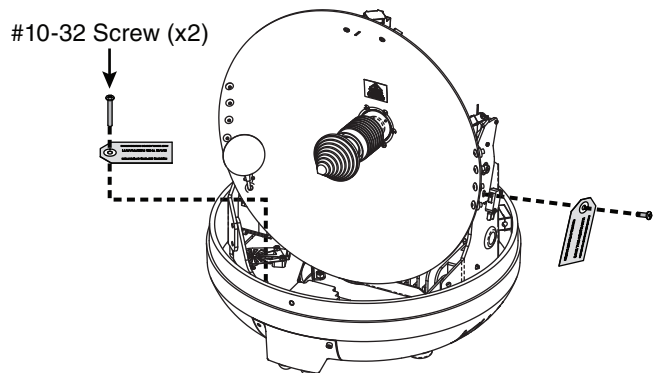

Figure 13: Shipping Restraints



# 7 Prepare the Antenna Cables

Follow these steps to prepare and route the RF and power/data cables.

## Prepare the Customer's RF Cables

You need to connect two 75Ω RF coax cables from the antenna to the belowdecks ICM. Refer to Figure 14 to determine the type of cables and connectors required for your cable run. Then prepare both of them as described below.

### IMPORTANT!

- If you use RG-11 RF cables 80-100 ft (25-30 m) in length, you can avoid the modem commissioning step. See “Commission the Modem” on page 24.
- RF cables must be rated for 75Ω, not 50Ω.
- Do not use RG-6 cable, as it will damage the system. Use of any cables not specified in Figure 14 will void the warranty.
- Low-quality, poorly terminated, or improperly installed RF cables are the most common cause of system problems. Terminate all RF cables with high-quality “F” connectors using the proper stripping/crimping tools, exactly to the manufacturer’s specifications. See page 39 for instructions on terminating LMR cables.
- Make sure the center conductor pin at each end of the finished cables is free of burrs and 1/4" (0.20"-0.28") (5-7 mm) in length, measured from inside the nut to the tip, to ensure proper engagement.
- (LMR cables only) Make sure there is no gap between the end of the cable jacket and the start of the connector.
- When determining cable lengths, don't forget to account for service loops, 14" (35 cm) in diameter, at each end.

**NOTE:** If you only need to run RG-11 RF cables, you may use the pre-terminated 50 ft (15 m) RG-11 cables from KVH (KVH part no. S32-1087-50), and omit the pigtail cables described in the next section.

Figure 14: RF Cable Options

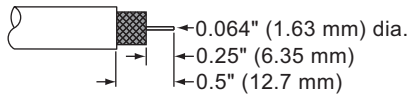
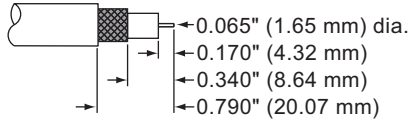
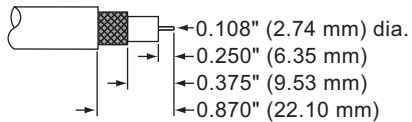
RG-11	
Max. length	100 ft (30 m)
KVH part no.	50 ft (15 m): S32-0566-50 100 ft (30 m): S32-0566-0100
Connector	Belden SNS11AS*
Tools	Belden CST596711 and L3011B (KVH part no. 72-0493)
Strip lengths	 <ul style="list-style-type: none"> <li>←0.064" (1.63 mm) dia.</li> <li>←0.25" (6.35 mm)</li> <li>←0.5" (12.7 mm)</li> </ul>
LMR-400-75	
Max. length	200 ft (60 m)
KVH part no.	100 ft (30 m): S32-0944-0100 150 ft (45 m): S32-0944-0150 200 ft (60 m): S32-0944-0200
Connector	Times Microwave EZ-400-FMH-75*
Tools	Times Microwave TK-400EZ-75 (KVH part no. 72-0374-75**)
Strip lengths	 <ul style="list-style-type: none"> <li>←0.065" (1.65 mm) dia.</li> <li>←0.170" (4.32 mm)</li> <li>←0.340" (8.64 mm)</li> <li>←0.790" (20.07 mm)</li> </ul>
LMR-600-75	
Max. length	300 ft (100 m)
KVH part no.	150 ft (45 m): S32-0945-0150 200 ft (60 m): S32-0945-0200 300 ft (90 m): S32-0945-0300
Connector	Times Microwave EZ-600-FMH-75*
Tools	Times Microwave TK-600EZ (KVH part no. 72-0375-75**)
Strip lengths	 <ul style="list-style-type: none"> <li>←0.108" (2.74 mm) dia.</li> <li>←0.250" (6.35 mm)</li> <li>←0.375" (9.53 mm)</li> <li>←0.870" (22.10 mm)</li> </ul>

\* Cables from KVH include the proper connectors.

\*\* LMR tool kits from KVH include a torque wrench.

# 7

## Continued Prepare the Antenna Cables

### Connect the Customer's RF Cables to the Supplied Pigtail Cables

**IMPORTANT!**

Use of the supplied RG-11 pigtail cables is **mandatory** if you are using LMR cables. Do not connect LMR-400-75 or LMR-600-75 cables directly to the antenna.

- Clean and dry the RF cables' connectors.
- Label both ends** of the customer's RF cables. Label one cable "TX;" label the other "RX."
- Fill half of the inner body of the customer's "TX" RF cable's connector with the supplied silicone grease to prevent moisture and corrosion.
- Connect and **SLOWLY** hand-tighten the "TX" RF cable to the feed-thru adapter of one of the supplied 3 ft (90 cm) RG-11 pigtail cables, allowing the grease to diffuse and settle into the entire space within the connector (see Figure 15).
- Make sure the RF cable's connector is tightened all the way into the pigtail cable's feed-thru adapter. Then tighten it with a 7/16" torque wrench set to 20 in.-lbs.
- Repeat steps c-e to connect the "RX" RF cable to the other pigtail cable.

### Route the Cables Belowdecks

- Keep the connector end of the power/data cable and the right-angle connector ends of the RF cables at the antenna location.

*NOTE: Longer power/data cables are available from KVH (see Figure 16).*

- Route the opposite ends of the power/data and RF cables belowdecks through the 3.5" (89 mm) cable access hole. Leave an adequate service loop, at least 14" (35 cm) of slack, in the cables at the antenna location.
- Route the cables to the ICM. Be sure to always maintain the minimum bend radius in the RF cables (see Figure 17).

Figure 15: Connecting the Pigtail Cables to the RF Cables

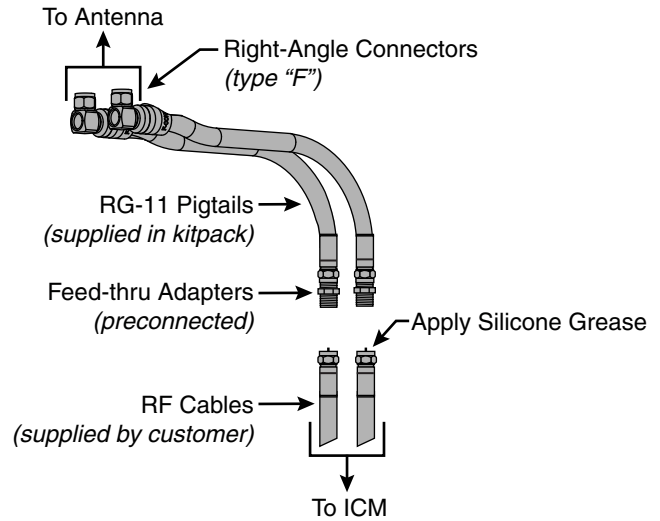

Figure 16: Longer Power/Data Cable Options

Length	Part Number
150 ft (45 m)	32-1031-0150
300 ft (90 m)	32-1031-0300

Figure 17: Minimum Bend Radius of RF Cables

Cable Type	Minimum Bend Radius
RG-11	4.5" (11.5 cm)
LMR-400-75	4.5" (11.5 cm)
LMR-600-75	6" (15.3 cm)

# 8

## Wire the Antenna

Follow these steps to connect the antenna cables.

- a. Connect the power/data cable to the "Power/Data" jack on the bottom of the antenna (see Figure 18). Hand-tighten until the connector locks in place.
- b. Using the supplied 3 mm Allen hex key, remove the connector cover from the antenna's baseplate. Save the cover and the four M4 cap screws for later use.
- c. Clean and dry the antenna's RF connectors.
- d. Place one of the supplied rubber washers over the "MRx" jack on the bottom of the antenna, as shown in Figure 19.
- e. Fill half of the inner body of the "RX" pigtail cable's connector with silicone grease.
- f. Connect and **SLOWLY** hand-tighten the "RX" pigtail cable to the "MRx" jack on the antenna, allowing the grease to diffuse and settle into the entire space within the connector.
- g. Make sure the "RX" pigtail cable's connector is tightened all the way into the antenna's connector. Then tighten it with a 7/16" torque wrench set to 20 in.-lbs. Make sure the rubber washer compresses against the baseplate.
- h. Repeat steps d-g to connect the "TX" pigtail cable to the antenna's "MTx" jack.
- i. Wipe off any excess grease from the cables.
- j. Seal all above deck RF cable connections with silicone sealant or equivalent.
- k. Reattach the connector cover and secure in place with the M4 cap screws.
- l. Secure the cables near the antenna connectors to relieve stress.
- m. Seal the cable access hole, as required.

### IMPORTANT!

The integrity and reliability of the RF cables is critically important. Make certain that these cables are properly terminated, sealed against seawater and corrosion, strain-relieved, protected from abrasion, and free of stress.

Figure 18: Antenna Cable Connections

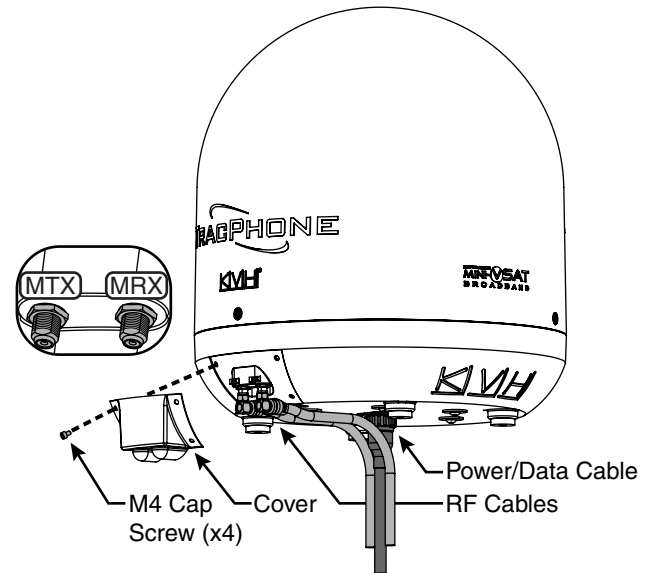
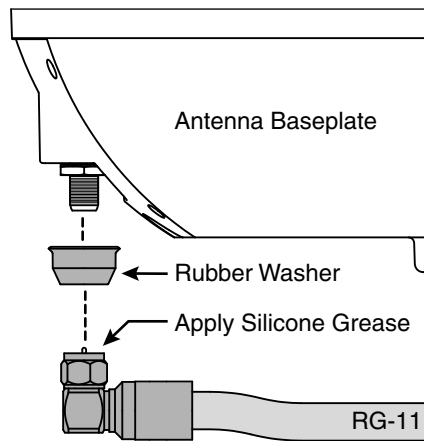



Figure 19: Connecting RF Cables to the Antenna



# 9 Mount the Antenna

Follow these steps to mount the antenna.

- a. Place the antenna over the holes drilled in the mounting surface and make sure the forward arrow inside the baseplate points toward the bow and is parallel to the vessel's centerline (see Figure 20). The antenna's baseplate should rest squarely atop the foam seal.

	<b>CAUTION</b>
Be sure to observe the safe handling instructions in the Material Safety Data Sheet (MSDS) provided with the anti-seize lubricant.	

- b. Apply a thin layer of the supplied anti-seize lubricant to the threads of the four 1/4"-20 bolts to prevent galling.

<b>IMPORTANT!</b>
Be sure to insert the mounting bolts from above and use the supplied hardware for a secure connection.

- c. At each of the four baseplate mounting holes, place a 5/8" diameter flat washer on a 1/4"-20 bolt and insert the bolt into the hole from above (see Figure 21).

<b>IMPORTANT!</b>
Use caution if you're using power tools. High installation speeds can damage the threads.

- d. Secure each mounting bolt to the mounting surface using a 1" diameter flat washer and a 1/4"-20 lock nut from below. Tighten all four bolts until the four rubber feet on the baseplate are bottomed against the mounting surface and the foam seal is fully compressed.
- e. Reinstall the radome onto the antenna. Secure in place with the three #10-32 screws you removed earlier (see Figure 12 on page 10). Then install a protective plastic cap (supplied in the kitpack) over each radome screw.

Figure 20: Forward Arrow in Antenna Baseplate

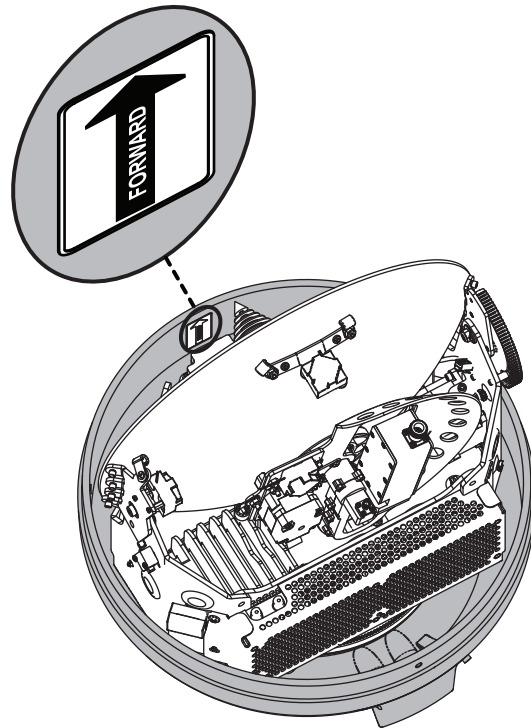
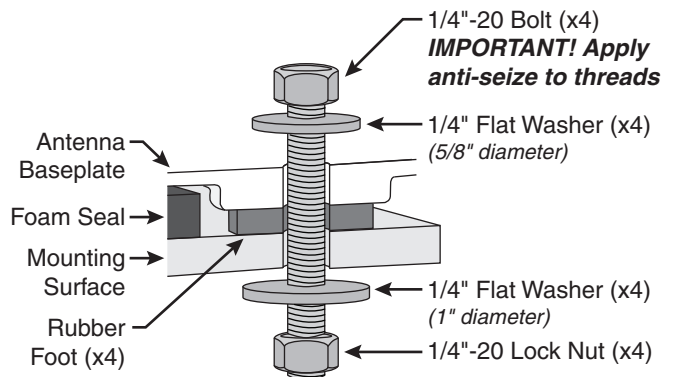

Figure 21: Mounting the Antenna (Side View)



# 10 Wire the ICM

Follow these steps to wire the belowdecks equipment (see page 49 for a complete wiring diagram).

## Connect the ICM Jumper Cables

Connect the supplied straight-through Ethernet jumper cable from the “B1” jack to the “B2” jack on the rear panel of the ICM (see Figure 22).

## Attach the Wi-Fi Antennas

Connect the two supplied Wi-Fi antennas to the rear panel of the ICM (see Figure 22).

## Connect the Antenna Power/Data Cable

- First dress the power/data cable from the antenna. Strip back the insulation of each wire approximately 1/4" (6 mm) and gently twist each wire to ensure a good electrical connection.
- Connect the antenna power/data cable to the supplied 16-position terminal strip connector as shown in Figure 23.

### IMPORTANT!

The diagram refers to wires by **body color/ stripe color**. For example, “Brown/White” means the brown wire with white stripe.

- Place the terminal strip connector into the base of the supplied cable shroud as shown in Figure 24.
- Secure the end of the power/data cable to the base of the shroud using the supplied clamp. This clamp will help relieve stress on the cable. Secure the clamp in place with the two screws.
- Carefully fit all of the power/data cable’s wires within the base of the shroud.
- Snap the shroud’s cover onto the base. Be sure not to pinch any wires between the cover and the base.
- Plug the terminal strip connector into the rear panel of the ICM.

Figure 22: Jumper Cable and Wi-Fi Antenna Connection

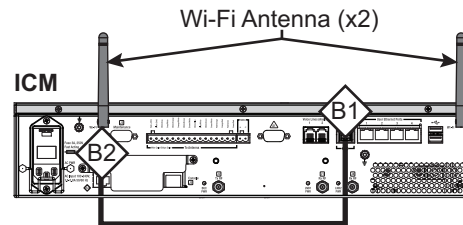

Figure 23: Antenna Power/Data Wiring

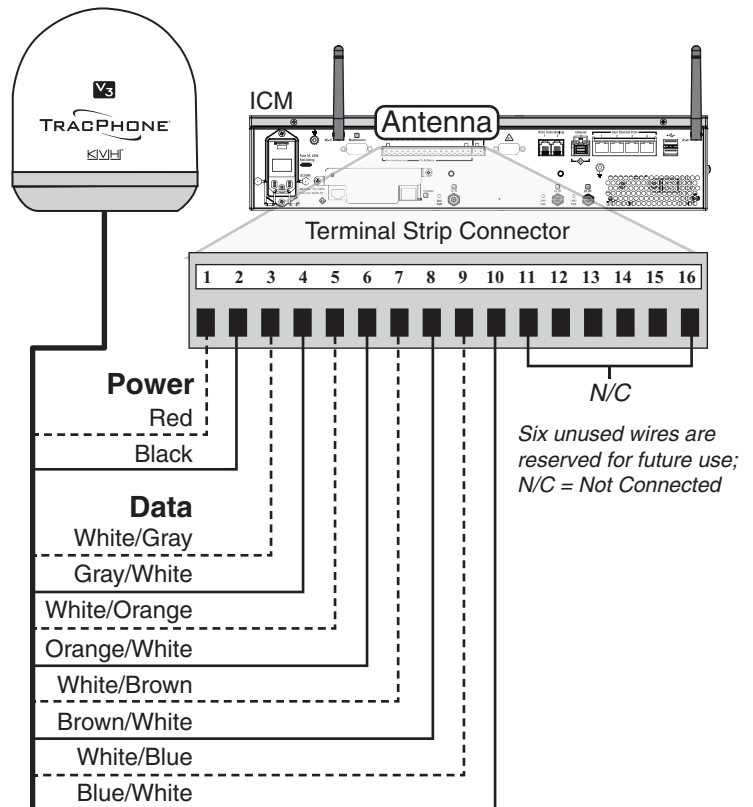
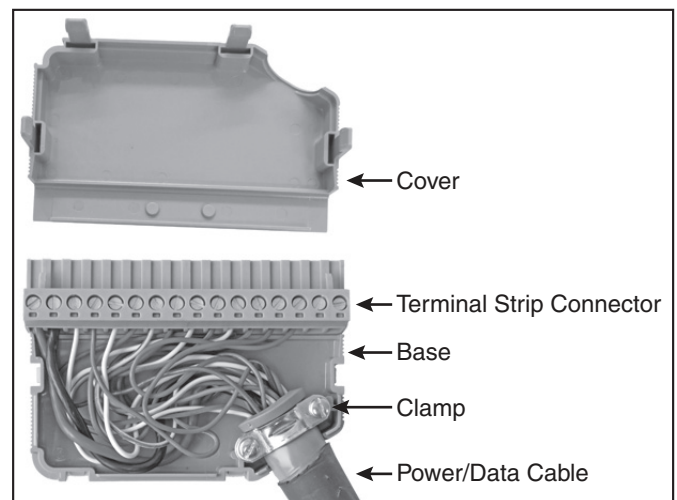

Figure 24: Power/Data Cable Shroud



# 10 Continued Wire the ICM

## Connect an NMEA 0183 Talker

The antenna **requires** a vessel heading input from a customer-supplied NMEA talker. Optionally, you can also provide a vessel position input to serve as a backup to the antenna's internal GPS.

To supply both the required heading and the optional position to the ICM, you can either connect an NMEA 0183 talker that transmits both messages, or connect two devices using an NMEA data multiplexer, such as Actisense® model NDC-4.

- a. Configure the customer's NMEA 0183 talker(s) to transmit a compatible message or messages at 4800 baud (see Figure 25). Refer to "Verifying the NMEA 0183 Message" on page 48 to confirm that the message is transmitting successfully.

**NOTE:** The system does not accept messages that conform to either the NMEA 2000 or NMEA 0183 HS standards.

- b. Make sure the data message(s) includes the checksum, identifiable by a \*xx field at the end of the data sentence (e.g., \$HEHDT,123.4,T\*1F).
- c. Connect the NMEA 0183 talker or NMEA data multiplexer to the supplied 2-position terminal strip connector as shown in Figure 26.
- d. Plug the terminal strip connector into the rear panel of the ICM.

Figure 25: Compatible NMEA 0183 Inputs

Data Type	Compatible Messages
True or Magnetic Heading	\$--HDG \$--HDM \$--HDT \$--OSD \$--THS \$--VHW
Position	\$--RMC

Figure 26: NMEA Wiring

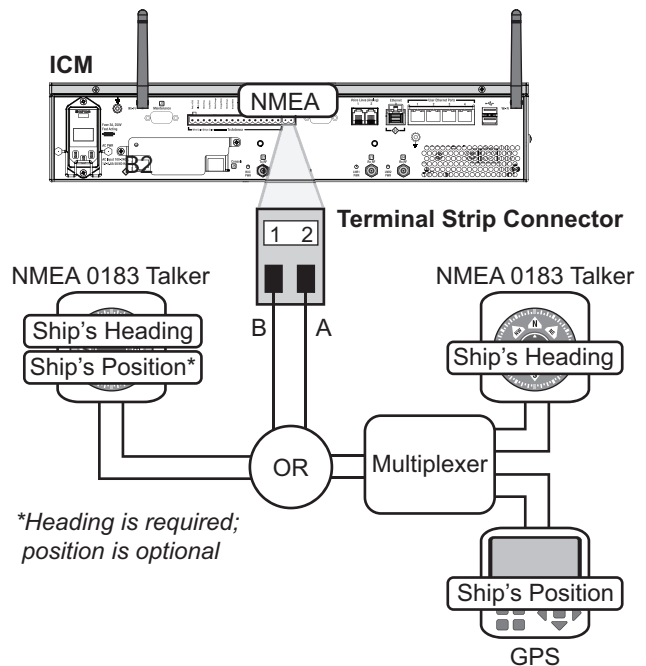

# 10 Continued Wire the ICM

## Connect the RF Cables

### IMPORTANT!

If you are using LMR-600-75 RF cables, do not connect them directly to the ICM. Connect the supplied 1 ft (30 cm) pigtail cables between the RF cables and the ICM. Be sure to use the pigtail cable labeled "TX ONLY" at the ICM's "J2 Tx RF" jack.

- Connect the RF coax cable labeled "RX" to the "J1 Rx RF" jack on the back of the ICM (see Figure 27). Hand-tighten, then tighten with a 7/16" torque wrench set to 20 in.-lbs.
- Connect the RF coax cable labeled "TX" to the "J2 Tx RF" jack on the back of the ICM. Hand-tighten, then tighten with a 7/16" torque wrench set to 20 in.-lbs.

### IMPORTANT!

Be sure the RF cables are terminated properly with type "F" connectors.

- Remove the tag from the "J4 Rx RF" jack on the back of the ICM (see Figure 28). Then connect the supplied RF terminator to the "J4 Rx RF" jack according to the tag's instructions. Hand-tighten, then tighten with a 7/16" torque wrench set to no more than 20 in.-lbs.

### IMPORTANT!

The RF terminator (KVH part no. 19-0972) must be installed on the "J4 Rx RF" jack. Improper cable installations are not covered under KVH warranty.

Figure 27: Antenna RF Transmit and Receive Wiring

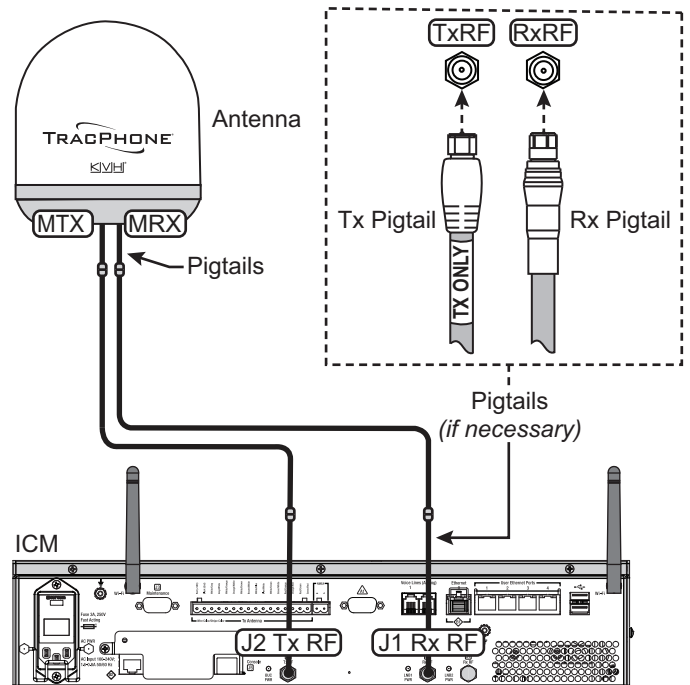
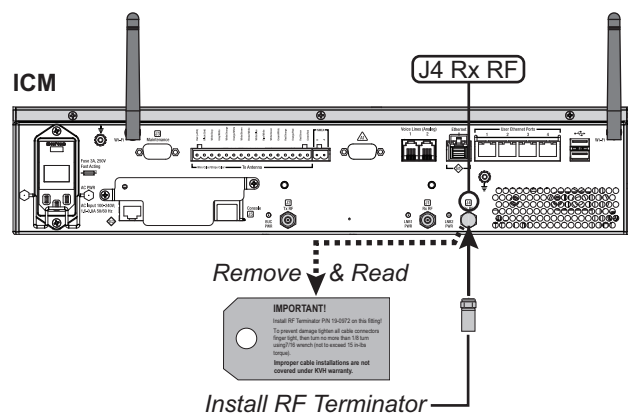

Figure 28: RF Terminator and Instructions Tag



# 11 Connect Power

Before you begin, be sure that you understand the following important requirements:

## AC Power Requirements

The TracPhone system is designed to run on 3-wire single-phase AC power (hot, neutral, and ground). Voltage between hot-neutral and hot-ground should each measure between 100-240 VAC.

Many large ships use two-phase, split-phase, or delta power instead (3 wires: hot, hot, and ground; no neutral). In this case, voltage between hot-hot measures the proper voltage (100-240 VAC); while hot-ground measures only half the voltage (50-120 VAC). Although the TracPhone system can operate on this type of power, the excess voltage present on the second phase will cause a small amount of current to leak onto ship's ground. This leakage current might be unacceptable on some vessels. So check with the customer or ship's electrician and get permission before you run the system on two-phase power. Also be sure to ground the system, as explained below.

If two-phase power is the only available power source onboard, and if leakage current is unacceptable, KVH recommends that you install a suitable isolation transformer to supply single-phase power to the antenna system and run a ground wire from the transformer to ship's ground. In addition, since ground fault protection devices cannot detect faults behind a transformer, you will also need to install a ground fault monitoring device between the isolation transformer and the antenna system if ground fault protection is required on the vessel.

## Grounding Requirements

Proper grounding of the TracPhone system to ship's ground is critically important, as it protects the equipment from lightning and electrostatic discharges (ESD). Failure to ground the chassis of the ICM risks damage to the antenna and electric shock.

Figure 29: AC Power Options

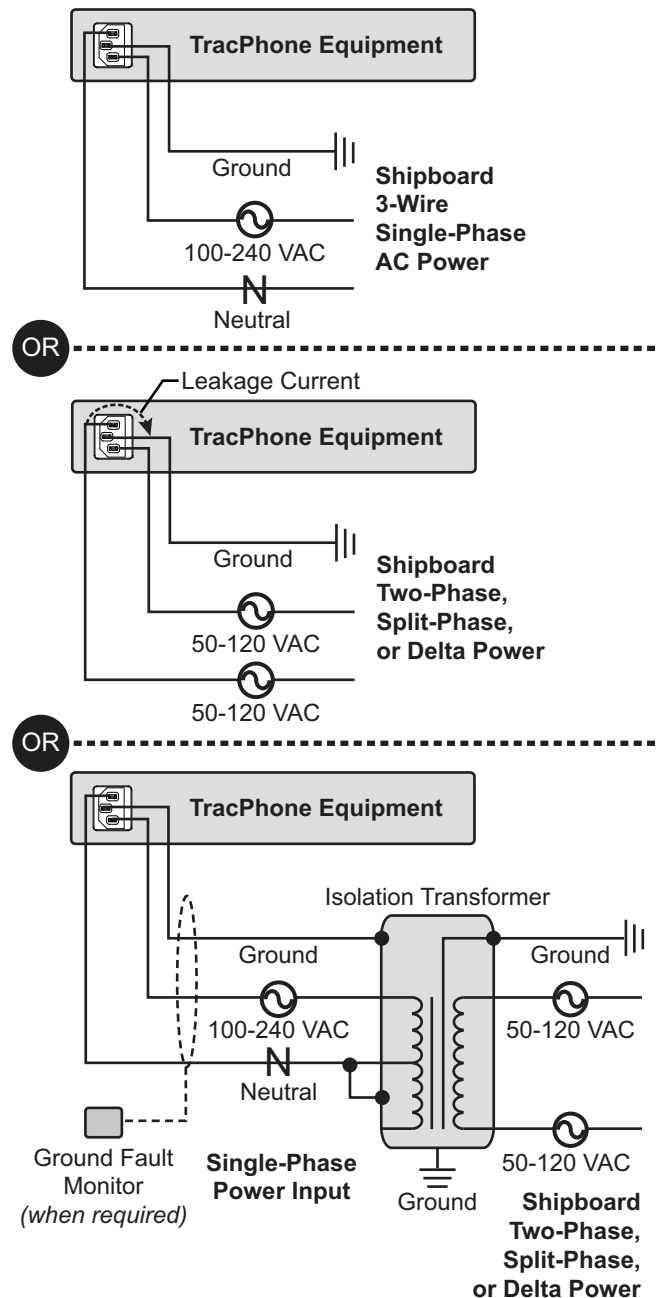

# 11 Continued Connect Power

Once you have read and understand the requirements described on page 18, follow these steps to connect power to the TracPhone system.

- a. Before you begin, disconnect vessel power and be sure the vessel is properly grounded in accordance with marine standards.
- b. Connect the supplied ground wire from the ground point on the ICM rear panel to ship's ground (see Figure 30).
- c. Connect the supplied AC power cord to the ICM.



## WARNING

**Failure to ground the TracPhone system properly to ship's ground will cause an unsafe floating ground condition, risking damage to the antenna and electric shock, potentially resulting in DEATH.** In a floating ground condition, the difference between the equipment's chassis ground and the ship's ground can measure well over 100 volts, when it normally should not exceed 2 volts. Therefore, always measure the difference in potential between chassis ground and ship's ground to make certain that there is no dangerous floating ground condition, even if the ground pin of the vessel's AC power plug appears to be intact.

- d. Using tie-wraps, secure all wires to the strain-relief bracket at the back of the ICM (see Figure 31). Leave enough slack for easy serviceability.
- e. Double-check all of your wiring.
- f. Plug the ICM power cord into the vessel's 100-240 VAC supply.

**NOTE:** Consider installing an uninterruptible power supply (UPS) to avoid service interruptions during power outages and transitions to/from shore power.

Figure 30: Power Wiring

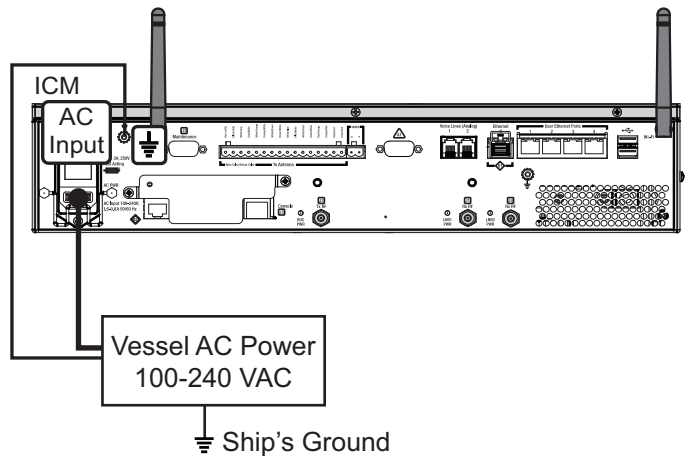
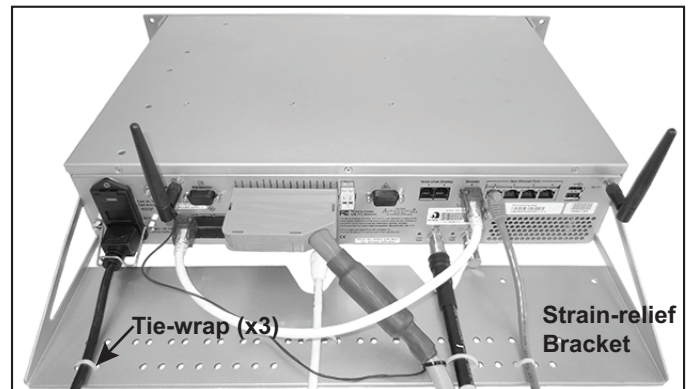

Figure 31: Strain-Relief Bracket



# 12 Turn On the System

Follow these steps to turn on the system.

- a. Ensure the antenna has a clear, unobstructed view of the sky.
- b. Apply vessel power to the TracPhone system.
- c. Press the power button on the front of the ICM (see Figure 32). The button's light should illuminate blue.
- d. Measure the AC and DC voltages between the ground point on the ICM's rear panel (chassis ground) and ship's ground. Make sure you measure less than 2 VAC/2 VDC.
- e. Wait at least 5 minutes for system startup.
- f. After the startup sequence is complete, verify that the ICM's Control Unit status light is lit solid green and the Antenna and Modem lights are lit solid or flashing green (see Figure 33).
- g. Connect your PC to the "User Ethernet 1" port on the rear panel of the ICM (see Figure 34).
- h. Turn off the Wi-Fi on your PC and keep it turned off while connected to the ICM.
- i. Open a web browser on your PC and enter the following address: **http://minivsat.kvh**.

Verify that the TracPhone V3-HTS web interface appears in your browser. If the web interface is not displayed, enter the ICM's IP address (*you can find this address on the LCD: go to Settings > Network Settings > IP Assignments*) and make sure your PC is configured for DHCP (see page 43).

Figure 32: Power Button

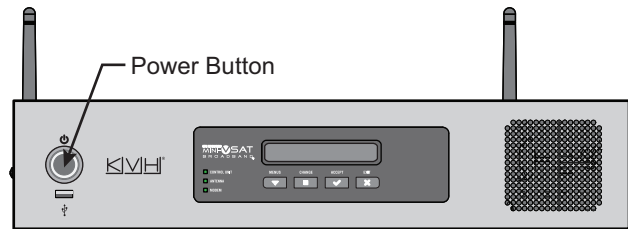

Figure 33: Status Lights

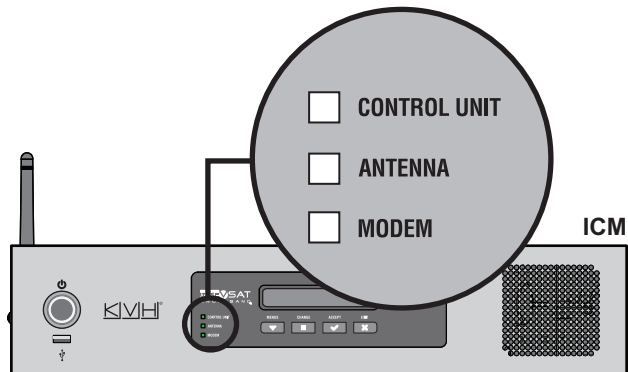
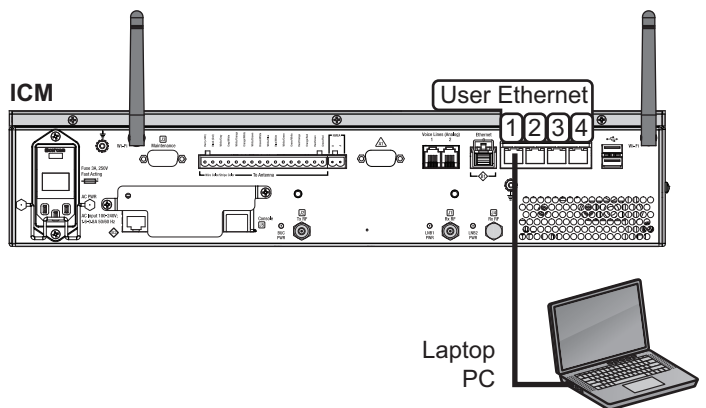

Figure 34: Connecting Your Laptop to the ICM



# 13 Update the System Software

## If Necessary

Follow these steps to ensure the latest software is installed in the TracPhone system.

### Check the Current Software Version

- Go to the TracPhone V3-HTS web interface and click the **Updates** tab. Note the displayed ICM/Antenna software version (see Figure 35).
- If the reported software version is earlier than the latest version you downloaded from the KVH Partner Portal, update the system following the steps below.

### Update the Software, If Necessary

*NOTE: This procedure explains how to update the software using the TracPhone V3-HTS web interface. However, you can also update the software using the mini-VSAT iPhone®/iPod Touch® app, a USB drive, or, if the system is activated, via the antenna's Internet connection (airtime charges may apply). Details are available in the Help.*

- Click **Choose File**.
- At the Login window, enter the default password: “**password**”.
- Click **Browse** and navigate to the file you saved on your laptop (see Figure 36).
- Click **Check File**.
- At the confirmation message, click **Update**.
- Wait for the software update to complete. It might take up to 40 minutes.

Figure 35: Updates Page on Web Interface

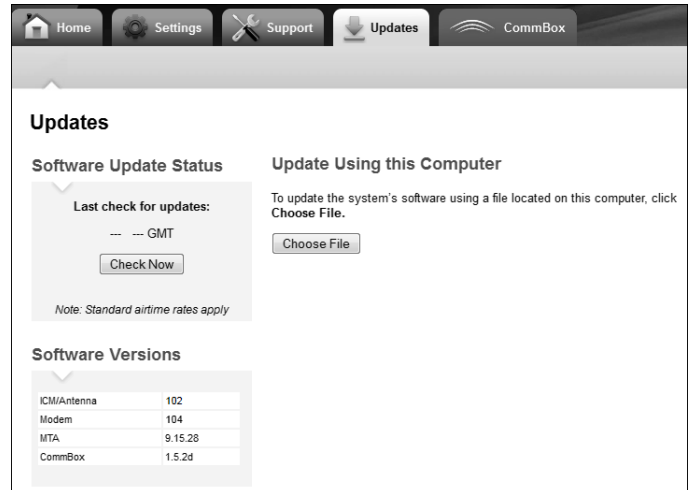
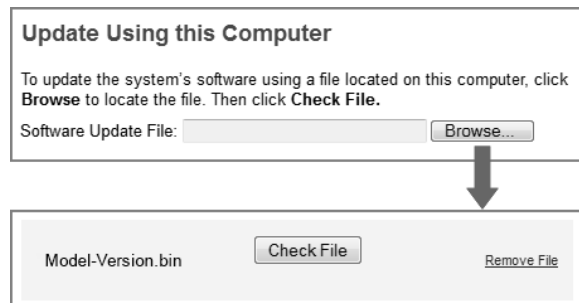

Figure 36: Update File Selected for Upload



# 14 Customize the Web Interface

Follow these steps to customize the web interface for the customer's use.

## Set the Administrator Password

The user must be logged in as an administrator to make changes to the system's configuration. Follow these steps to change the administrator password to something unique.

- At the TracPhone V3-HTS web interface, click the **Settings** tab. Then click **Account**.
- In Security, click **Edit**.
- For the current password, enter the default password: "password" (see Figure 37).
- Enter and then re-enter the new password. Then click **Save Settings**.

## Enter the Vessel Name

The vessel name is displayed on the home page and in all support communications. Follow these steps to enter the correct vessel name.

- At the TracPhone V3-HTS web interface, click the **Settings** tab. Then click **Account**.
- In Vessel Name, click **Edit**.
- Enter the vessel name (see Figure 38). Then click **Save Settings**.

## Assign Phone Line Name(s)

The phone line names are displayed on the home page and in all support communications. Follow these steps to assign a name (i.e., location) to Line 1. You also might want to enter "Not Used" for Line 2, since the system is limited to a single phone line.

- At the TracPhone V3-HTS web interface, click the **Settings** tab. Then click **Other**.
- In Phone Line Names, click **Edit**.
- Enter names for Lines 1 and 2, as needed (see Figure 39). Then click **Save**.

Figure 37: Setting the Administrator Password



The screenshot shows a web form titled "Security". Below the title is the instruction "Change the administrator's login password." There are three password input fields: "Enter the current password:" with a masked field of 8 dots; "Enter the new password:" with a masked field of 12 dots and a "Strong" indicator (a checkmark in a box) to its right; and "Re-enter the new password:" with a masked field of 12 dots. Below the fields are "Cancel" and "Save Settings" buttons. A note next to the new password field reads: "(between 4 and 20 characters long, with at least one letter and one number, case sensitive)".

Figure 38: Entering the Vessel Name



The screenshot shows a web form titled "Vessel Name". Below the title is the instruction "Change the name displayed on the Home page and in support communications." There is a "Vessel Name:" label followed by a text input field containing the text "Britanic". Below the input field are "Cancel" and "Save Settings" buttons.

Figure 39: Assigning Phone Line Names

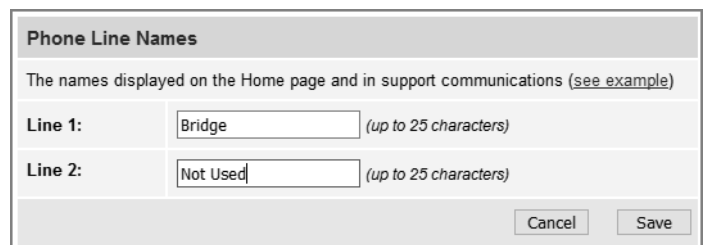

The screenshot shows a web form titled "Phone Line Names". Below the title is the instruction "The names displayed on the Home page and in support communications (see example)". There are two rows: "Line 1:" with a text input field containing "Bridge" and a note "(up to 25 characters)"; and "Line 2:" with a text input field containing "Not Used" and a note "(up to 25 characters)". Below the rows are "Cancel" and "Save" buttons.

# 15 Set Up No-Transmit Zones

Optional

To prevent exposure to RF energy (see the hazard area illustration on page 1), you can configure up to two no-transmit zones for areas where crew and/or passengers frequent (see Figure 40). The system will disable the transmitter whenever the antenna is pointing within one of these zones.

Follow these steps to set up a no-transmit zone.

- Determine the necessary azimuth range for the no-transmit zone(s). You will need to enter, in clockwise order, beginning and ending azimuths that define the outer boundaries of the zone(s) **relative to the antenna's forward arrow**, which should be pointing toward the bow (see Figure 41).

**NOTE:** Each no-transmit zone must span at least 5°. Therefore, be sure to set the beginning and ending azimuths at least 5° apart.

- At the TracPhone V3-HTS web interface, click the **Settings** tab. Then click **No-Transmit Zones**.
- Click **Edit**.
- Click **Enforce Zones** (see Figure 42).
- Enter the azimuth range for Zone 1.
- Enter the azimuth range for Zone 2, if required.
- Click **Save All Settings**.
- At the confirmation message, click **Save**.

Figure 40: Example of a No-Transmit Zone

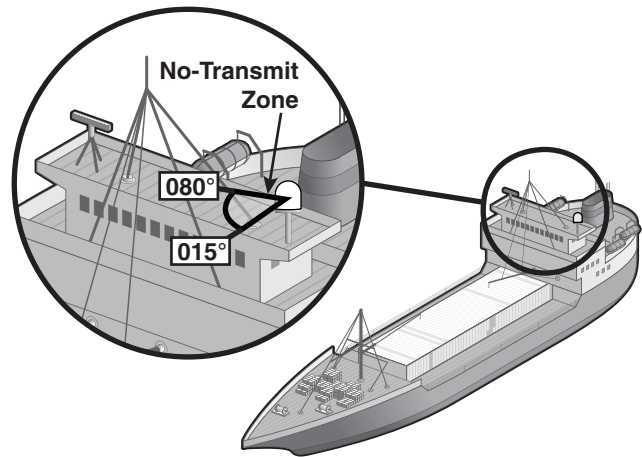

Figure 41: Azimuths Relative to Antenna's Forward Arrow

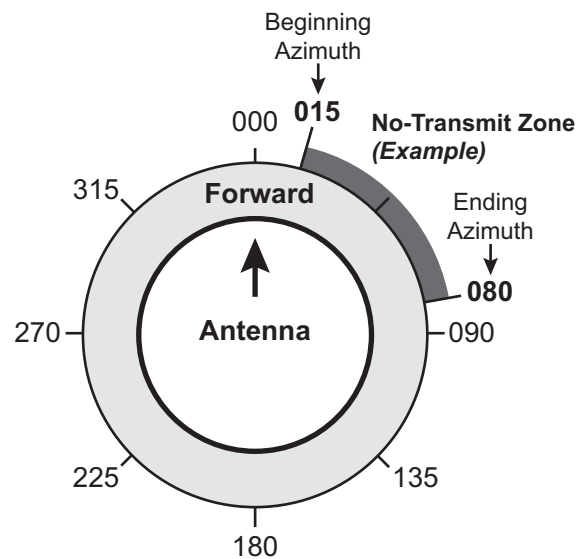
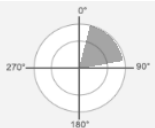



Figure 42: No-Transmit Zones Page of Web Interface

No-Transmit Zone Ranges:	
<input checked="" type="radio"/> <b>Enforce Zones</b> <i>The antenna will not transmit within the zone(s) specified below.</i>	
<input type="radio"/> <b>Ignore Zones</b> <i>The antenna will be able to transmit in any direction without restriction. Be sure everyone stays the minimum safe distance away from the antenna.</i>	
Zone 1	Zone 2
<b>Azimuth Range</b>	<b>Azimuth Range</b>
From: 15 °	From: --- °
To: 80 °	To: --- °
	
<i>Select Enforce Zones first. Zone must span more than 5°.</i>	<i>Select Enforce Zones first. Zone must span more than 5°.</i>
<input type="button" value="Cancel"/> <input type="button" value="Clear All Zones"/> <input type="button" value="Save All Settings"/>	

# 16 Commission the Modem

Follow these steps to commission the ICM's built-in modem, if required.

**IMPORTANT!**

If the modem was commissioned at the factory (look for a notice attached to the ICM), you can skip this step as long as you are using RG-11 RF cables 80-100 ft (25-30 m) in length. If a notice is not attached to the ICM, or you used a different RF cable type or length, or you installed a different antenna from the unit that shipped with the ICM, you must complete this step.

This process is required to determine the 1 dB compression point of the BUC (block up-converter) (see Figure 43) and the maximum transmit power. The process takes about 30 minutes to complete.

- a. Ensure the antenna has a clear, unobstructed view of the sky.
- b. At the TracPhone V3-HTS web interface, verify that the antenna is tracking the service satellite and the system is online (see Figure 44).
- c. Click the **Support** tab and gather all the information listed on the Modem Commissioning Worksheet (supplied in the Welcome Kit).
- d. Call KVH Technical Support. KVH will coordinate with the Network Operations Center (NOC) to complete the remaining commissioning steps over the air. You will just need to provide the information you noted on the worksheet.

**NOTE:** If the NOC is unable to access the system remotely over the satellite connection, you will need to assist with the commissioning process by adjusting settings at the modem's local web interface as directed by the NOC. Refer to "Full Commissioning Steps" on page 33 for details.

Figure 43: BUC's 1 dB Compression Point Determination

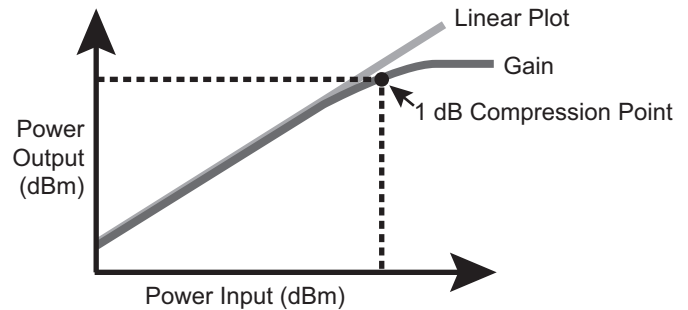

Figure 44: Good Service Connection Indicated on Home Page

My VSAT Status	
Connection Status	Antenna State
 <b>ONLINE</b> SNR: 5.80dB	<b>TRACKING</b>

Figure 45: Modem Commissioning Worksheet Information

No.	Item	Value
①	Antenna State "TRACKING" required	
②	Orbital Slot	
③	Satellite Name (see table below)	
④	Beam ID	
⑤	Frequency	
⑥	Management IP	
⑦	Vessel Position	Lat:
		Long:
⑧	Modem State "IN_NETWORK" required	
⑨	FL Carrier Symbol Rate (2nd field)	
⑩	Modem S/N	

# 17 Test the System

Follow these steps to test the system for proper operation.

- a. Ensure the antenna has a clear, unobstructed view of the sky.
- b. Verify that the antenna is tracking the service satellite and the system is online, as indicated by the Home page of the TracPhone V3-HTS web interface (see Figure 46).
- c. On the Home page, make sure the vessel's heading is displayed in the Real-time Vessel & VSAT Satellite Display (see Figure 47). If it is not shown, check your wiring to the NMEA 0183 talker.
- d. Enter the following address in your web browser: <http://test.minivsat.net>.  
  
Verify that the Welcome page appears, indicating good communication between the TracPhone system and the land-based hub (see Figure 48).
- e. Turn on all other electronic equipment above deck within the proximity of the antenna. Verify that the system continues to operate without any degradation in performance.
- f. Fill out the Installation Checklist (provided in the Customer Welcome Kit) and return it to KVH. Refer to the instructions on the form.

**IMPORTANT!**

Submission of the Installation Checklist is **required** to certify the quality of your installation.

Figure 46: Good Service Connection Indicated on Home Page

My VSAT Status	
Connection Status	Antenna State
 <b>ONLINE</b> SNR: 5.80dB	<b>TRACKING</b>

Figure 47: Heading Displayed on Home Page

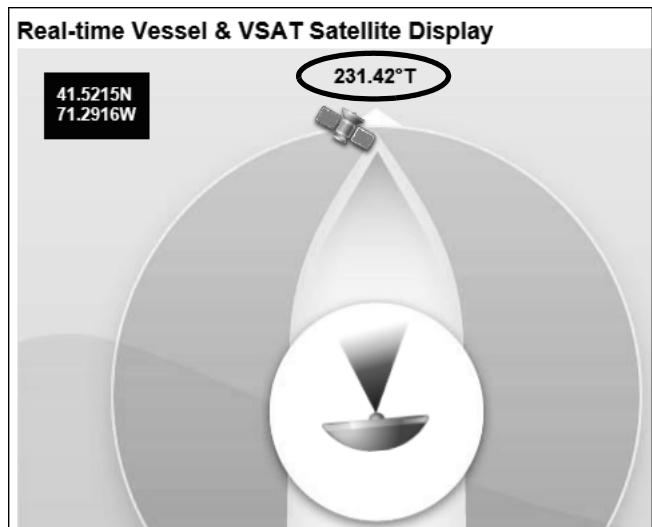
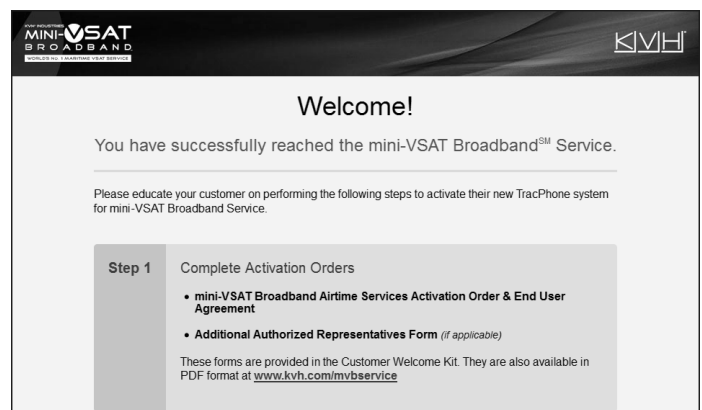

Figure 48: Welcome Page for Testing



# 18 Configure the Network

The ICM includes four Ethernet ports and a built-in wireless access point (WAP) that can be configured in a variety of ways to meet the customer's needs (see Figure 49). Some of the most common ICM network configurations can be selected directly from the TracPhone V3-HTS web interface. Follow these steps to select one of these configurations. If the customer requires a custom configuration, please contact KVH Network Services at [networkservices@kvh.com](mailto:networkservices@kvh.com).

**NOTE:** The customer may also change the ICM's network configuration at the mini-VSAT Manager (go to [www.mykvh.com](http://www.mykvh.com)). To access the mini-VSAT Manager, the customer will need to log in with the username and password provided by KVH at the time of activation.

- a. At the TracPhone V3-HTS web interface, click the **Settings** tab. Then click **Network Settings**.
- b. In Network Configuration, click **Edit**.
- c. Select an option from the **Configuration** drop-down menu. Then click **Save** (see Figure 50 and Figure 51).
- d. At the confirmation message, click **Save**.
- e. Follow the additional instructions on the following pages for your chosen configuration.

**Standard Configuration:** Go to page 27

**Static IP Configuration:** Go to page 28

**Access Control Configuration:** Go to page 29

Figure 49: ICM Ethernet Ports and Wireless Access Point

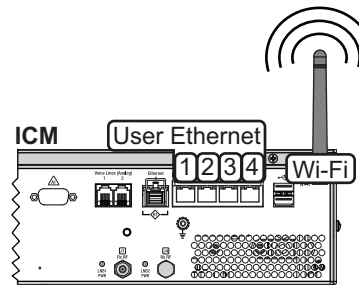

Figure 50: Selecting a Network Configuration

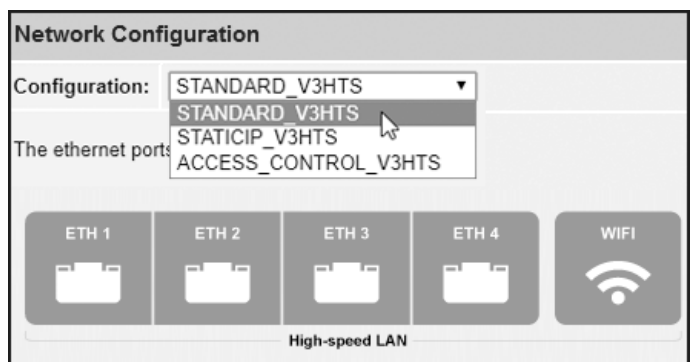

Figure 51: User Selectable Network Configurations

Option	Description
Standard Configuration	Ports 1-4, Wi-Fi: High-speed LAN with unrestricted access
Static IP Configuration	Ports 1-3, Wi-Fi: High-speed LAN with unrestricted access Port 4: Accessory LAN*
Access Control Configuration	Ports 1-3, Wi-Fi: High-speed LAN with access control Port 4: Accessory LAN*

\* Accessory LAN reserved for optional service, such as Global Static IP, external MTA, or Crew Calling.

# 18 Continued Configure the Network

## Standard Configuration

In a standard configuration, Ethernet ports 1 through 4 and the built-in WAP provide high-speed Internet access with no user logins or controls. Internet access is unrestricted. This is the default configuration. Follow these additional steps to configure the network.

- a. To enable the ICM's WAP for wireless access, follow the steps in "ICM Wireless Settings" on page 30.
- b. Connect the customer's computers and/or other network devices to the ICM (see Figure 53). You might wish to add an external WAP (or Wi-Fi router configured for bridge mode) to supplement Wi-Fi access.
- c. Make sure all computers are configured for DHCP addressing (see page 43). Devices connected to the ICM (via Ethernet cables or Wi-Fi) will receive IP addresses from the ICM via DHCP. The ICM serves as a router.

*NOTE: By default, the High-speed LAN has a gateway of 192.168.5.1 and assigns IP addresses in the 192.168.6.50-150 range. If this configuration conflicts with an existing onboard network, you may change the settings at the TracPhone V3-HTS web interface (go to Settings > Network Settings).*

Figure 52: Standard Configuration

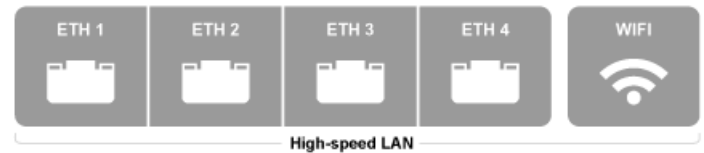
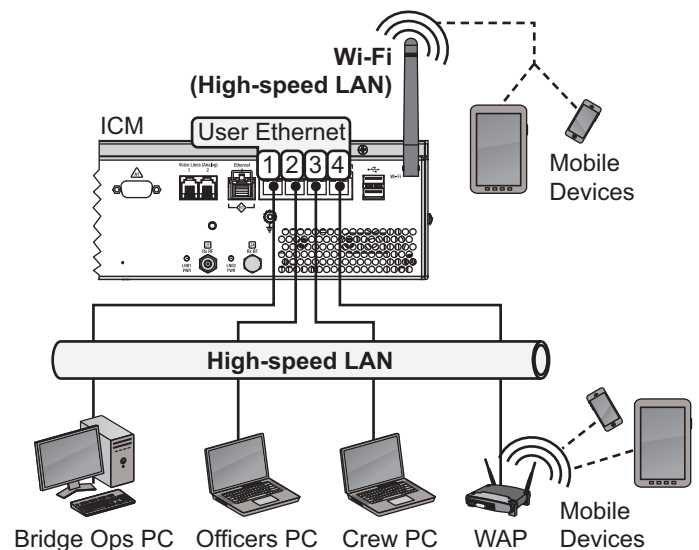

Figure 53: Standard Configuration Wiring Example



# 18 Continued Configure the Network

## Static IP Configuration

In a static IP configuration, Ethernet ports 1 through 3 and the built-in WAP provide high-speed Internet access with no user logins or controls. Internet access is unrestricted. Port 4 is reserved for an optional KVH service, such as Global Static IP.

Global Static IP service allows you to set up a network device with an IP address that can be accessed directly from the Internet. It does not receive an IP address from the ICM. If you require Global Static IP Service, follow these additional steps to configure the network.

### IMPORTANT!

A static IP address should only be assigned to a secure device, such as a firewall router.

- Ask the customer to fill out the request form at [www.kvh.com/staticip](http://www.kvh.com/staticip). In addition, the system must be activated for mini-VSAT Broadband service, and it must remain online until KVH configures the system over the air.
- Connect the static IP device to "User Ethernet" port 4 on the ICM (see Figure 55).
- The customer will need to configure the device's TCP/IP properties according to the instructions KVH will provide in an email upon fulfilling the static IP request.
- Connect all other (non-static IP) computers and/or network devices to "User Ethernet" ports 1-3 and Wi-Fi, as required. Follow the steps in "Standard Configuration" on page 27.

Figure 54: Static IP Configuration



Figure 55: Static IP Configuration Wiring Example

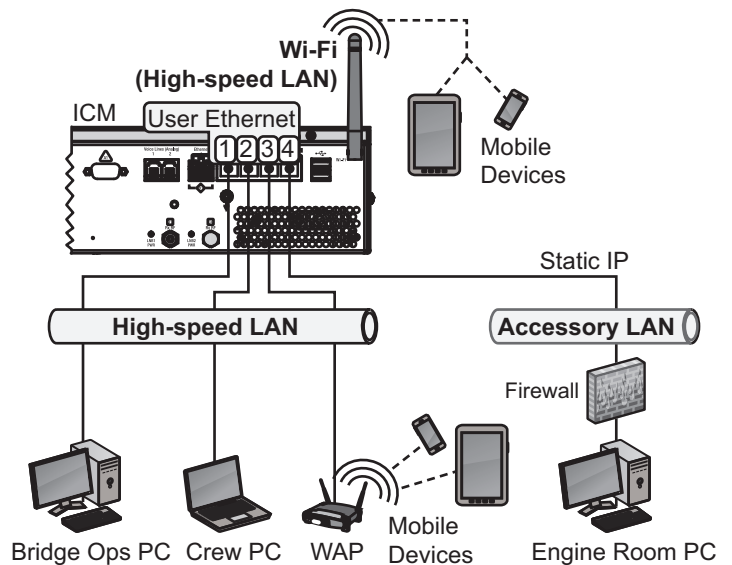

# 18 Continued Configure the Network

## Access Control Configuration

In an Access Control configuration, Ethernet ports 1 through 3 and the built-in WAP require a user login and provide high-speed Internet access. Port 4 is reserved for an optional KVH service, such as Global Static IP.

- This configuration is identical to the static IP configuration described on the previous page with one exception: user names, passwords, and data allocations are enforced to control access to the High-speed LAN. Internet access is restricted.
- Follow the steps in “Standard Configuration” on page 27.
- Inform the customer that they need to set up user names and passwords and allocate data for each High-speed LAN user at the mini-VSAT Manager ([www.mykvh.com](http://www.mykvh.com)).

## Optional CommBox Software

CommBox software extends the system’s network capabilities (see Figure 58). Two options are available:

- Standard Bundle:** Provides least cost routing, onboard firewall, web caching, web image compression, ad removal, and URL and content filtering
- Enterprise Bundle:** Adds automated file transfers, differential synchronization, mail relay server, web mail client, anti-spam and anti-virus filters, roaming crew accounts, and prepaid Internet and email services; integration with a CommBox hub is required

KVH will coordinate directly with the customer to select, install, and configure the appropriate bundle to meet their needs.

Figure 56: Access Control Configuration



Figure 57: Access Control Configuration Wiring Example

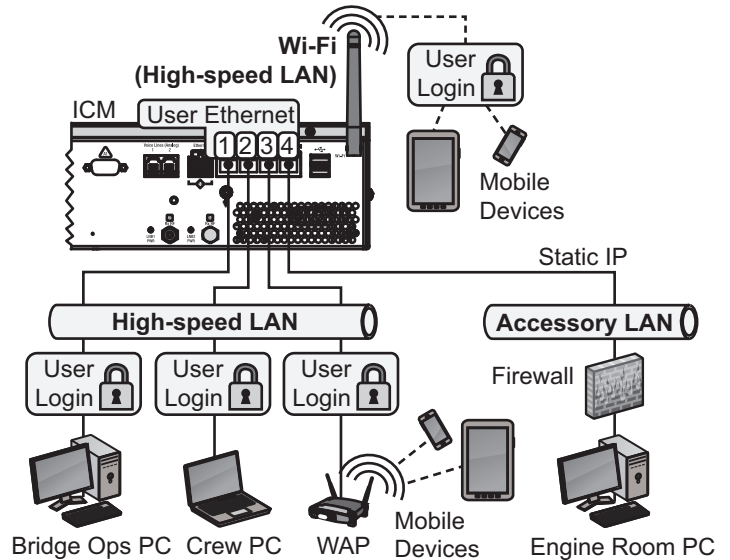

Figure 58: Available Network Options

Option	KVH Part No.
CommBox Standard Bundle*	35-0010
CommBox Enterprise Bundle*	35-0011

\* If the customer is interested in a CommBox solution, ask them to contact KVH Network Services at [networkservices@kvh.com](mailto:networkservices@kvh.com) for a consultation.

# 18 Continued Configure the Network

## ICM Wireless Settings

With Wi-Fi enabled, vessel devices can connect to the ICM via its built-in wireless access point (WAP) and receive IP addresses from the ICM via DHCP (see Figure 59). Follow these steps to enable and configure the WAP, if desired by the customer.

### IMPORTANT!

Establishing a wireless connection onboard a steel vessel might require a special external WAP and advanced networking expertise.

**NOTE:** The customer may also change the ICM's wireless settings at any time at the mini-VSAT Manager ([www.mykvh.com](http://www.mykvh.com)).

- At the TracPhone V3-HTS web interface, click the **Settings** tab. Then click **Network Settings**.
- In Wi-Fi Settings, click **Edit**.
- Set the following wireless options, then click **Save** (see Figure 60):
  - State:** Select On.
  - SSID:** Enter a unique name for the vessel network.
  - Protocol:** Select either 802.11b or 802.11g.
  - Security:** Select either security type – WPA2 or WEP (128-bit).
  - Password/Passphrase:** If you selected WPA2, enter a password (between 8-20 characters). If you selected WEP, enter a passphrase (must be 13 characters).
  - Channel:** Keep the default, or select any channel for wireless communications.

### IMPORTANT!

Failure to apply security settings will make the vessel's wireless network vulnerable to outside intrusion.

- At the confirmation message, click **Save**.

Figure 59: Wireless DHCP (Example)

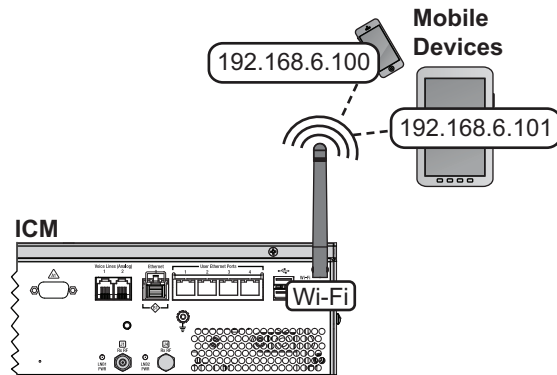

Figure 60: Wi-Fi Settings on the ICM

Wi-Fi Settings	
State:	<input checked="" type="radio"/> On <input type="radio"/> Off (default)
SSID:	<input type="text" value="MyVesselNetwork"/> (Up to 32 characters)
IP Address:	192 . 168 . 5 . 1
Protocol:	802.11b
Security:	WPA2
Password:	<input type="password" value="••••••••"/> (between 8 to 20 characters)
Channel:	7
<input type="button" value="Cancel"/> <input type="button" value="Save"/>	

# 19 Connect Voice Line Equipment

Follow these steps to connect the vessel's phone.

## Connect the Vessel Phone

Using the supplied RJ-11 cable, connect the customer's analog (not digital) phone or PABX to the "Voice Line 1" jack on the ICM (see Figure 61).

### **IMPORTANT!**

Do not connect anything to the "Voice Line 2" jack. Only "Voice Line 1" is enabled for use.

Figure 61: Connecting the Vessel Phone (Example)

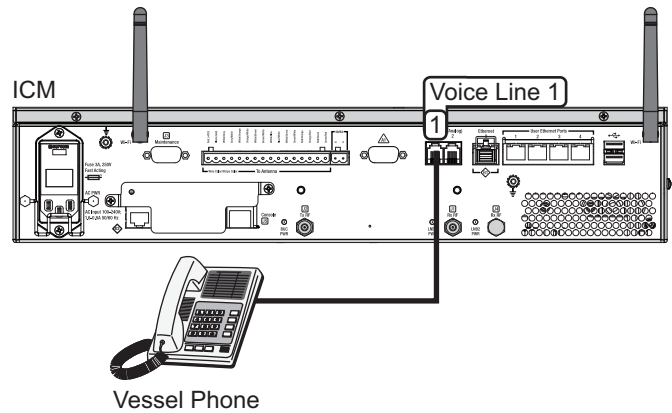

# 20 Educate the Customer

Give the Welcome Kit to the customer, make sure they know the administrator and Wi-Fi passwords, and show them how to use the system. Be sure they understand the following:

- **The antenna transmits RF energy that is potentially harmful.** Whenever the system is powered on, make sure everyone stays the minimum safe distance away from the antenna (see illustration on page 1). If no-transmit zones were set up, make sure the customer understands where they are.
- Read the End User Agreement carefully (available at [www.kvh.com/mvbcustomercenter](http://www.kvh.com/mvbcustomercenter)).
- Keep the radome installed on the antenna at all times. The radome protects the antenna's moving parts from wind, rain, and debris.
- The antenna must have a clear view of the sky to communicate via satellite. Common causes of blockage include masts, trees, buildings, and bridges (see Figure 63). Dirt buildup on the radome can also affect communications.
- The vessel must be located within the coverage area of the satellite (see [www.kvh.com/minivsatmap](http://www.kvh.com/minivsatmap)).
- The system must be activated for mini-VSAT Broadband service (see [www.kvh.com/mvbservice](http://www.kvh.com/mvbservice)).
- Data usage and overage alerts via email and text message, as well as user logins and their associated data allocations, can be configured easily over the Internet at the mini-VSAT Manager (see [www.mykvh.com](http://www.mykvh.com)).

## For More Information

Refer to the Help provided on the web interface's Support page (see Figure 64). The Condensed version is text only and resides on the ICM. The Extended version includes images and resides on the KVH website (airtime charges may apply).

Figure 62: Customer Welcome Kit



Figure 63: Example of Satellite Blockage

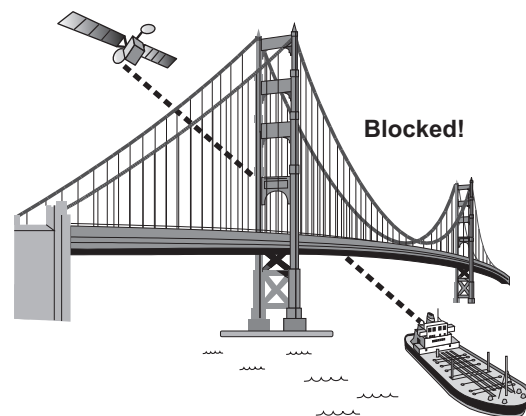
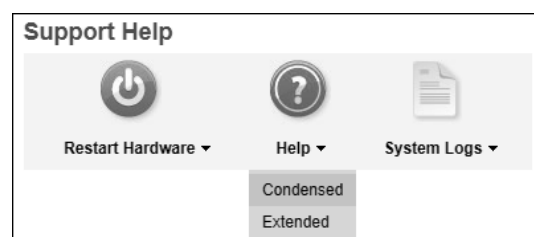

Figure 64: Help Options on Support Page



# A Full Commissioning Steps

## Appendix

If you need to commission the modem (see “Commission the Modem” on page 24), and if the NOC is unable to access the TracPhone system remotely over the satellite connection (a rare case), follow the steps below to access the built-in modem’s web interface and assist the NOC with the commissioning process.

- a. At the TracPhone V3-HTS web interface, click the **Support** tab.
- b. Click the link on the Support page to open the modem commissioning wizard (see Figure 65). Then log into the wizard using the administrator password you set up earlier. The default settings are as follows:
  - User Name: **admin**
  - Password: **password**
- c. At Step 1, click **Enter Commissioning Mode** (see Figure 66).

Figure 65: Support Page Link to Commissioning Wizard and Login

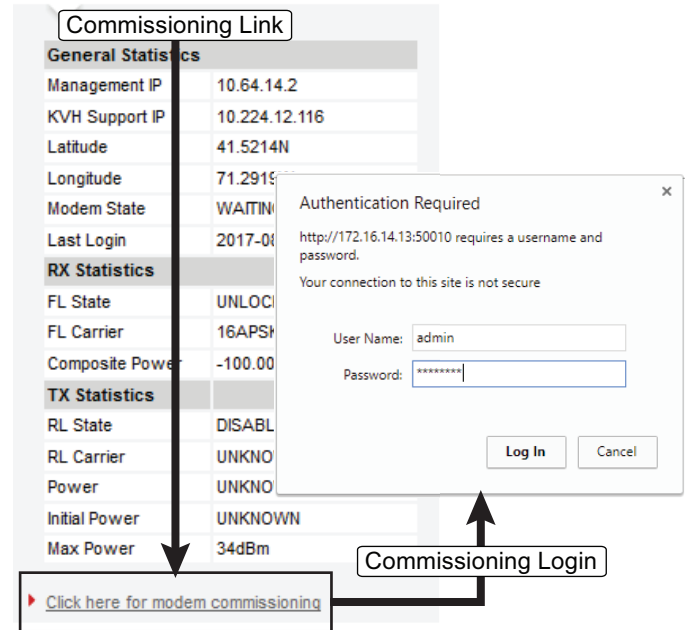
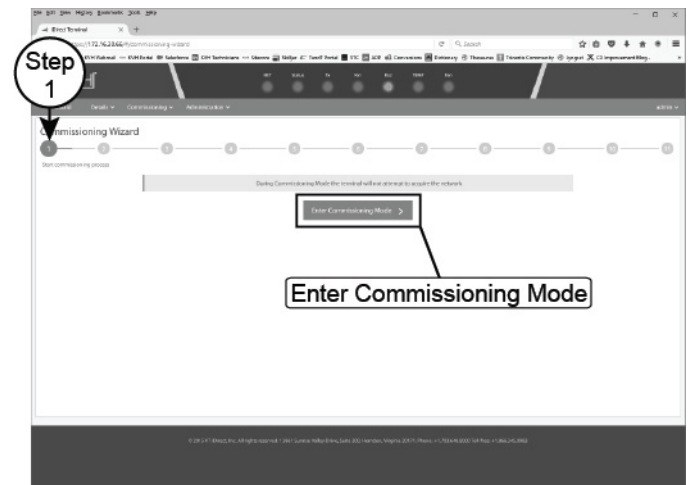

Figure 66: Commissioning Process – Step 1



# A

# Continued Full Commissioning Steps

## Appendix

- d. At Step 2, click **Continue without changes** (see Figure 67).

**IMPORTANT!**  
If you need to abort commissioning at any time, select **Exit commissioning mode**.  
*Cycling power will not revert the ICM to normal operation mode.*

- e. At Step 3, enter your latitude and longitude (see Figure 68).

**NOTE:** Select the direction (North/South, East/West) before entering each value.

- f. Enter the orbital slot (longitude) of the satellite the antenna is tracking.

**NOTE:** Select the direction (East/West) before entering the value.

- g. Click **Save remote location and continue** (see Figure 68).

Figure 67: Commissioning Process – Step 2

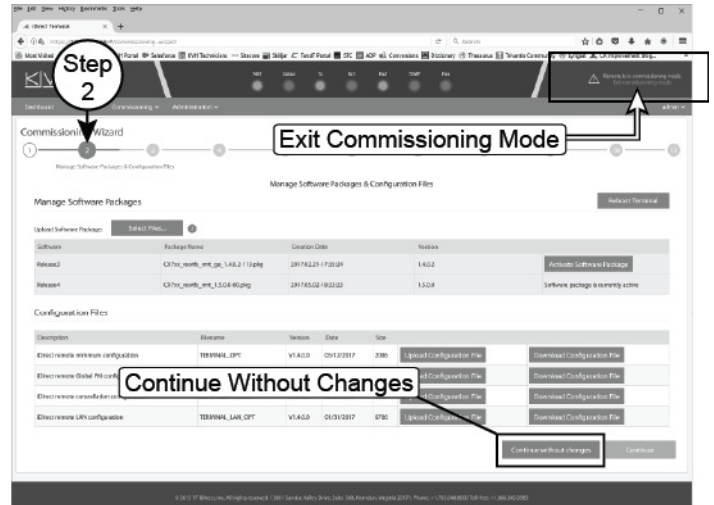
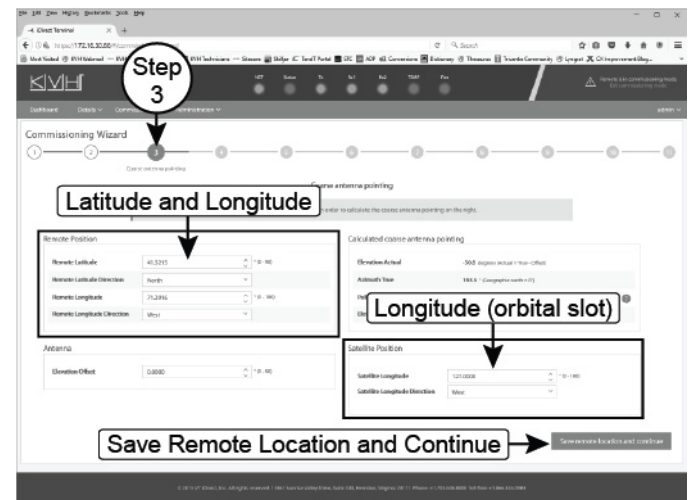

Figure 68: Commissioning Process – Step 3



# A

# Continued Full Commissioning Steps

## Appendix

- h. At Step 4, enter the satellite parameters provided by the NOC (see Figure 69). Verify that the Frequency and the FL Carrier Symbol Rate match the values on the worksheet, and enter zeros for Latitude Variance and Polarization Skew.

When you are done, click **Continue and position antenna** (see Figure 69).

- i. At Step 5, wait until you see the following (see Figure 70):

- Demod Lock Status: Locked
- Antenna Status: Functional, May Transmit

Then click **Stop Antenna pointing**.

Figure 69: Commissioning Process – Step 4

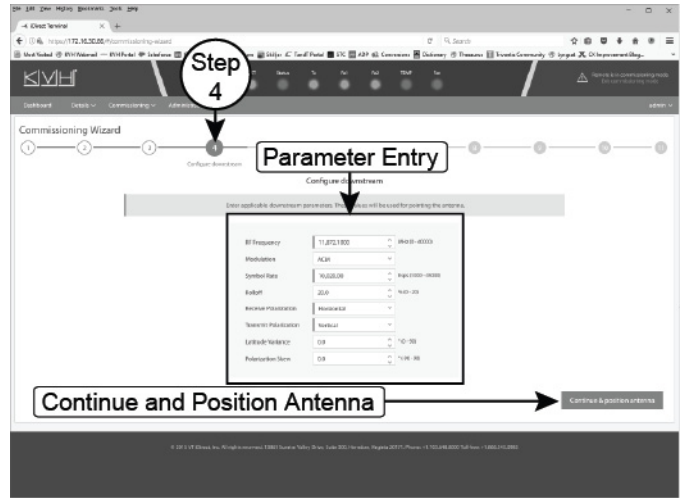
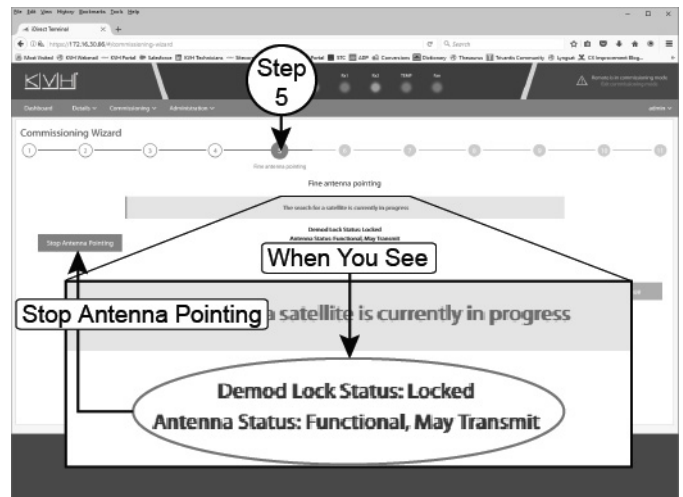

Figure 70: Commissioning Process – Step 5



# A Continued Full Commissioning Steps

## Appendix

- j. When **Start Antenna Pointing** appears, click **Continue** (see Figure 71).
- k. At Step 6, click **Continue** (see Figure 71).
- l. At Step 7, click **Skip** (see Figure 71).

Figure 71: Commissioning – Steps 5 Through 7

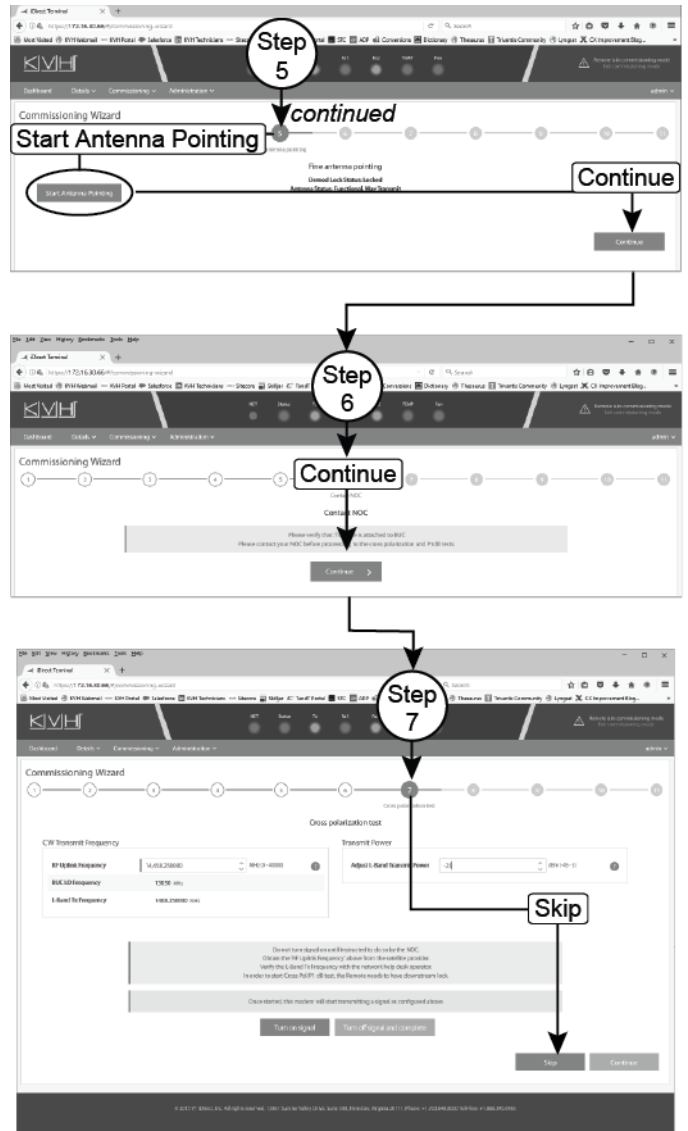

# A

# Continued Full Commissioning Steps

## Appendix

- m. At Step 8, select **CW modulation** and enter the **RF Uplink Frequency** and the initial **Transmit power** that the NOC provided (see Figure 72). Then click **Turn on signal**.
  - n. Continue by using **Adjust L-Band Transmit Power** to adjust the power in 1 dB increments as directed by the NOC and selecting **Apply changes** after each increment (see Figure 73). When directed, click **Turn off signal and complete**.
- NOTE: Take note of the P1dB compression value that is also provided by the NOC. You will enter this value later.*
- o. Next, select **BPSK modulation** and enter the **RF uplink frequency** and the **Starting transmit power** (see Figure 74) provided by the NOC. Then click **Turn on signal**.

Figure 72: Commissioning – Step 8: CW Modulation

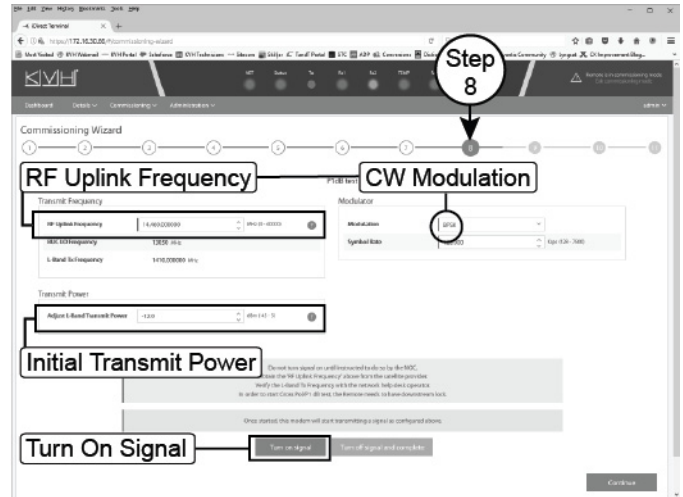

Figure 73: Commissioning – Step 8: CW Modulation continued

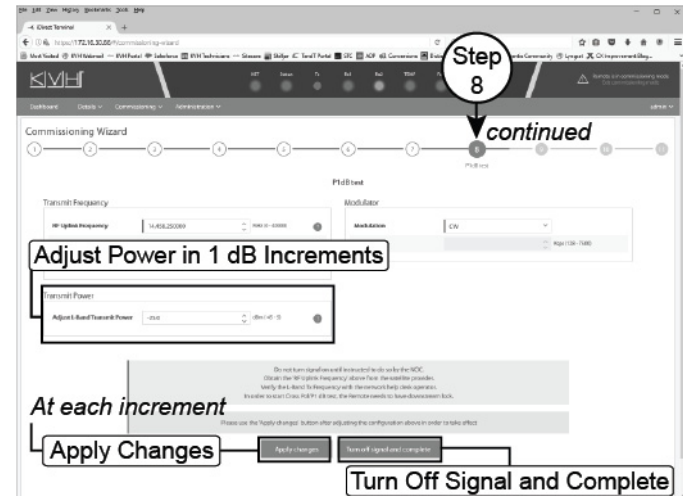
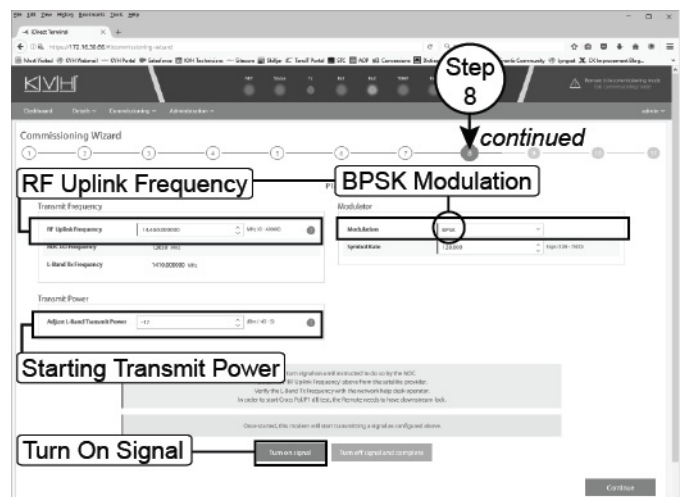

Figure 74: Commissioning – Step 8: BPSK Modulation



# A

# Continued Full Commissioning Steps

## Appendix

- p. Continue by using **Adjust L-Band Transmit Power** to adjust the power in 1 dB increments as directed by the NOC and selecting **Apply changes** after each increment (see Figure 75). When directed, click **Turn off signal and complete**.

*NOTE: Take note of the Maximum transmit (TX) power value provided by the NOC.*

- q. At Step 9, enter the **P1dB** compression value and the **Maximum transmit (TX) power** value provided by the NOC.

**IMPORTANT!**

Double-check your entries for the P1dB and Maximum TX Power. Maximum TX Power should **always** be one decibel less than the P1dB value. (For example, if P1dB = -15.0 dB then Max TX power = -16.0 dB.)

Then click **Continue** (see Figure 76)

- r. At Step 10, click **Exit commissioning mode** (see Figure 77).
- s. At Step 11, click **Return to dashboard** (see Figure 77).

Close the modem commissioning wizard.  
Commissioning is complete!

Figure 75: Commissioning – Step 8: BPSK Modulation *continued*

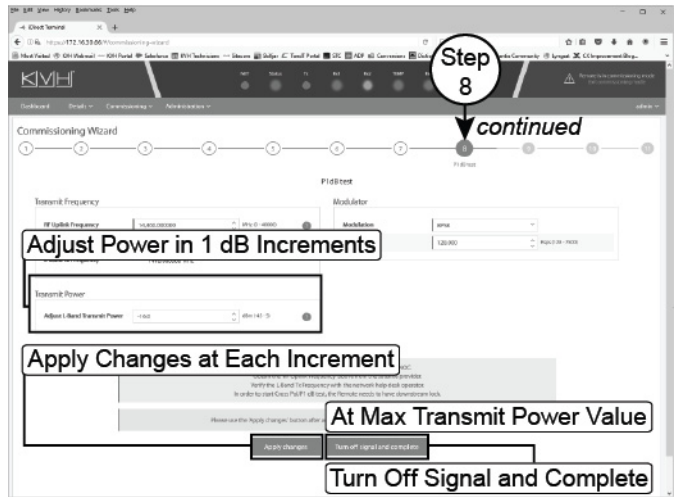

Figure 76: Commissioning – Step 9

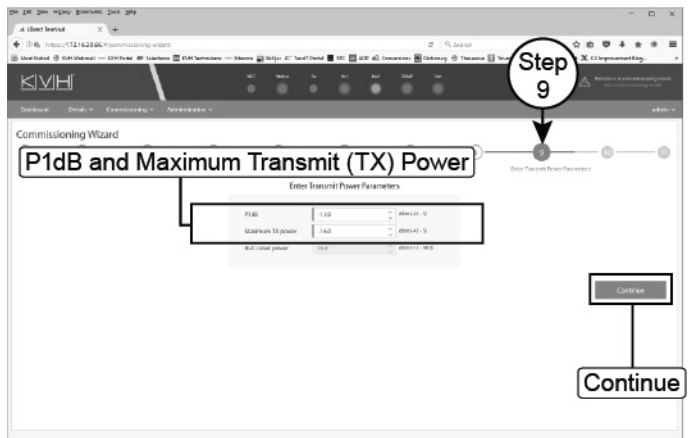
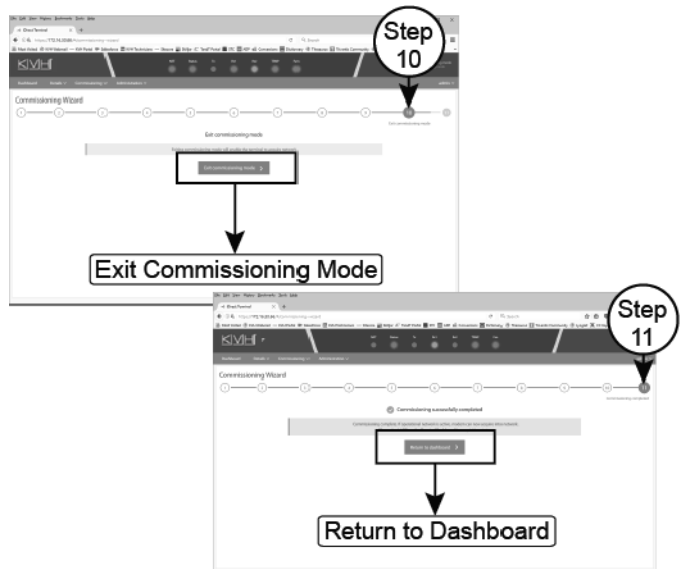

Figure 77: Commissioning – Steps 10 and 11



# B Terminating LMR RF Cables

## Appendix

These instructions explain how to terminate an LMR-400-75 RF cable with an EZ-400-FMH-75 “F” connector using the tools from the TK-400EZ-75 tool kit. The same steps also apply to an LMR-600-75 cable, with the exception of the tools used.

For more detailed instructions, refer to the Times Microwave website: [www.timesmicrowave.com](http://www.timesmicrowave.com).

1. Using the CCT-01 cutting tool, cut the cable evenly (see Figure 78).
2. Since cutting the cable can deform the end, gently round the end of the cable using a pair of needle-nose pliers (see Figure 79). Also make sure the center conductor is centered within the cable.
3. Place the heat shrink sleeve and metal ferrule onto the cable (see Figure 80).
4. Insert the end of the cable into the #1 end of the ST-400EZ stripping tool (see Figure 81). Then rotate the tool clockwise around the cable until the tool turns easily. The end of the cable should now be stripped to expose the center conductor.

Figure 78: Cutting the Cable



Figure 79: Reshaping the Cable

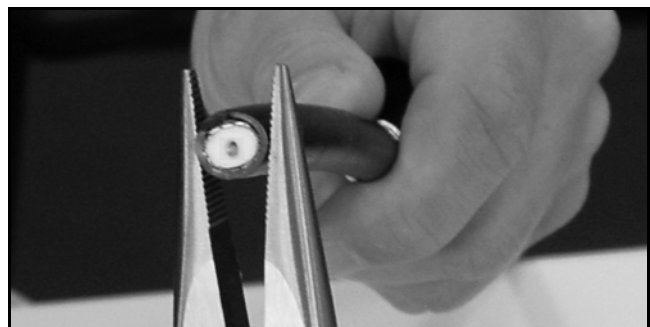

Figure 80: Placing the Heat Shrink Tubing and Ferrule

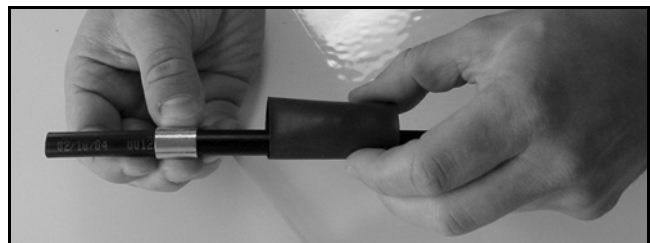

Figure 81: Stripping the End to Expose the Center Conductor



# **B** Continued Terminating LMR RF Cables

## **Appendix**

5. Using a utility knife, carefully remove any residual plastic from the center conductor, if necessary (see Figure 82).
6. Insert the end of the cable into the #2 end of the ST-400EZ stripping tool (see Figure 83). Then rotate the tool clockwise around the cable until the tool turns easily. This removes the cable jacket from the end of the cable, exposing the braid and dielectric (see Figure 84).
7. Using the DBT-02 tool, deburr and chamfer the center conductor (see Figure 85). Avoid nicking the aluminum tape covering the dielectric.

Figure 82: Removing Plastic Residue

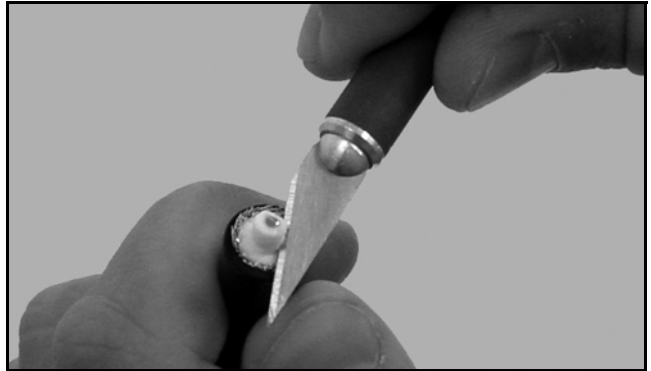

Figure 83: Stripping the Cable Jacket

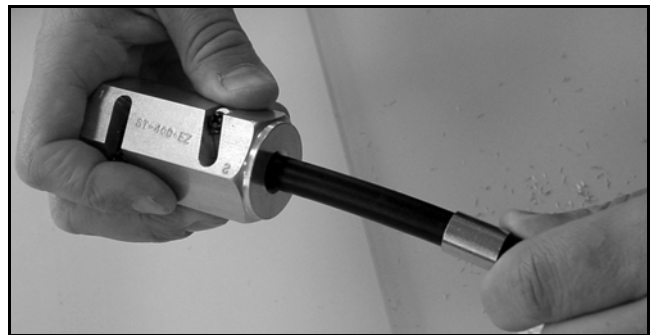
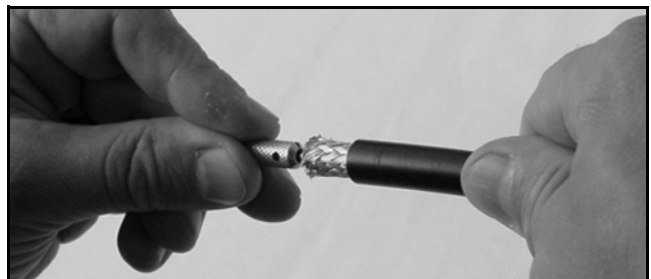

Figure 84: Cable Stripped, Exposing Dielectric



Figure 85: Deburring the Center Conductor



# B Continued Terminating LMR RF Cables

## Appendix

8. Gently flare the braid with your fingers (see Figure 86).
9. Insert the end of the cable into the connector body until the dielectric is firmly seated inside the connector (see Figure 87). Make sure there is no gap between the knurled end of the connector and the cable jacket. Also be sure all braid wires remain on the outside of the connector.

### **IMPORTANT!**

A common installation failure occurs when the connector is not seated properly onto the cable. In these cases, the cable's center conductor does not fully engage the electrical contacts inside the connector. To ensure full engagement, make certain that there is no gap between the cable jacket and the knurled end of the connector before you crimp on the ferrule. You may need to deburr and center the end of the conductor to achieve a good fit.

10. Trim any excess braid (see Figure 88), if necessary. The braid should assemble flush to within 1/16" (1.6 mm) of the connector shoulder.
11. Slide the ferrule over the braid until it is flush against the connector shoulder (see Figure 89).

Figure 86: Flaring the Braid



Figure 87: Pushing On the Connector

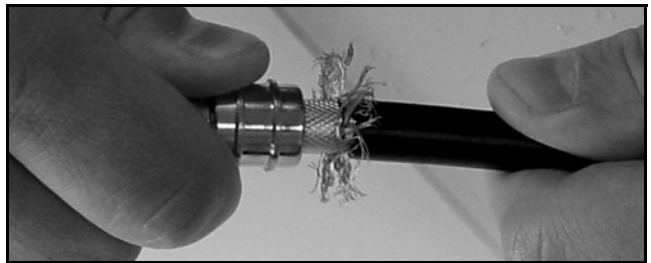

Figure 88: Trimming the Braid

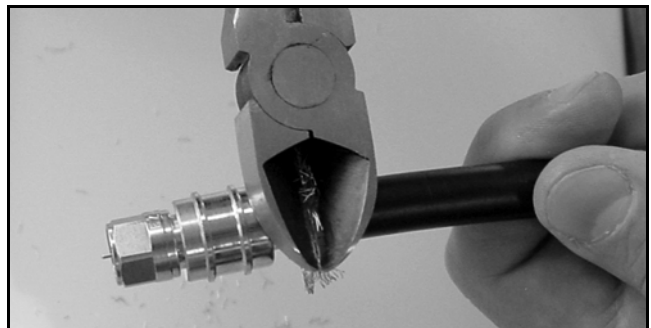
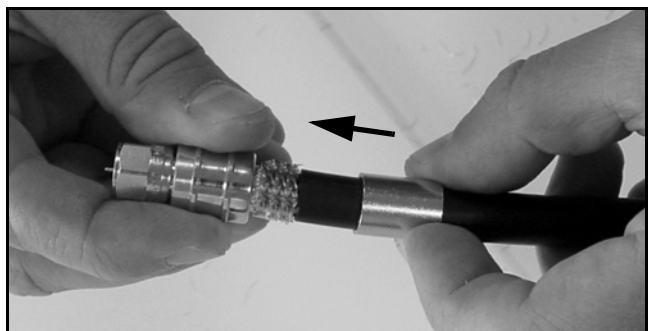

Figure 89: Sliding the Ferrule Over the Braid



# B Continued Terminating LMR RF Cables

## Appendix

12. Using an appropriate crimp tool (either the CT-400/300 or the HX-4 with Y1719 dies), crimp the ferrule in place (see Figure 90). Crimp as close to the connector body as possible.
13. Crimp the ferrule again, but further back from the connector. However, be careful not to crimp the cable jacket.
14. Slide the heat shrink sleeve over the connector body and heat it to compress it into place (see Figure 91). When you are done, the heat shrink should extend from the rear of the connector to the cable jacket. This forms a weather-tight seal.
15. Using a multimeter or similar device, check the continuity of the cable.
16. Ensure the center conductor pin measures between 0.20" and 0.28" (5-7 mm) in length, to ensure proper engagement with the mating connector (see Figure 92).

Figure 90: Crimping the Ferrule onto the Cable

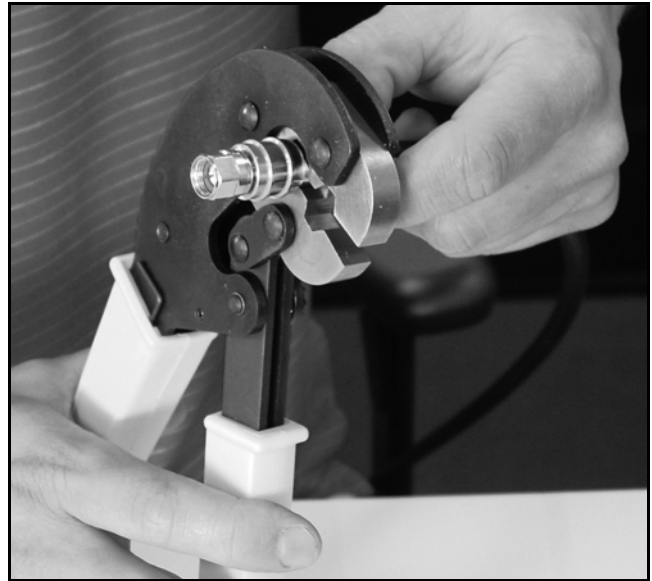
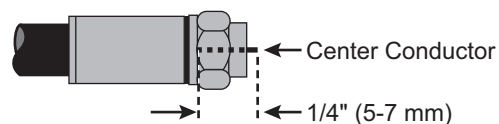

Figure 91: Applying the Heat Shrink Tubing



Figure 92: Proper



# C

# Configuring Computers for DHCP

## Appendix

Follow these steps to configure your computer for DHCP to allow it to receive an IP address from the ICM. The location of this configuration setting varies slightly by operating system.

**NOTE:** The computer must have a network interface card installed and all cabling must be 100 Mbps fast Ethernet UTP CAT-5 with RJ45 connectors.

### Windows 10

1. Turn on the computer.
2. Open the **Network and Sharing Center**. The easiest way to get there is to simply enter the name in the search box on the taskbar. You can also navigate to it from the Start menu: *Settings > Network & Internet > Ethernet > Network and Sharing Center*.
3. In Network and Sharing Center, click the **Ethernet** link for the Ethernet connection you are using.
4. In the Ethernet Status dialog box, click **Properties**. If this screen doesn't appear, just skip to Step 5.
5. In the Ethernet Properties dialog box, on the **Networking** tab, select **Internet Protocol Version 4**, and then click **Properties**.
6. In the Internet Protocol Properties dialog box, select **Obtain an IP address automatically** and **Obtain DNS server address automatically** (see Figure 93). Then click **OK**.
7. In the Ethernet Properties dialog box, click **Close**. Then click **Close** in the Ethernet Status dialog box.

Figure 93: Windows 10 - Internet Protocol Properties

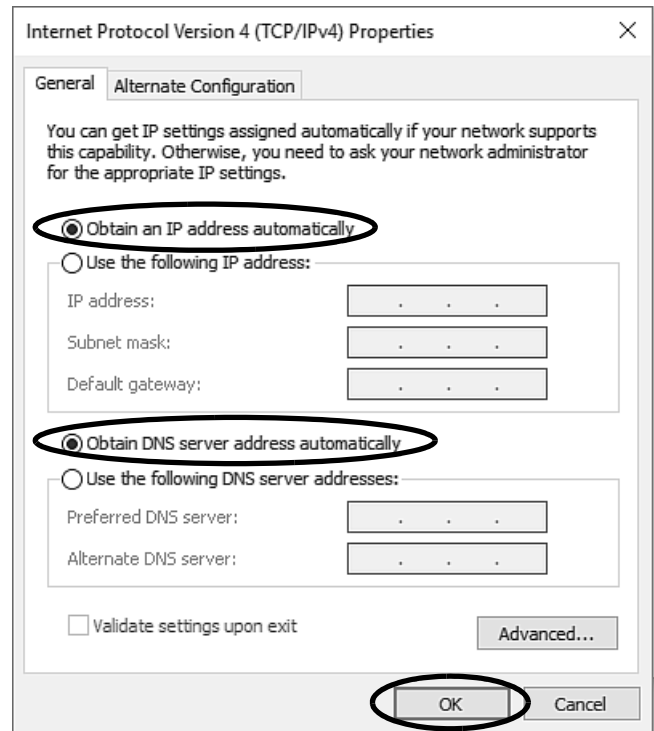

### Windows 8

1. Turn on the computer.
2. In Control Panel, double-click **Network and Sharing Center**. *To open the Control Panel, go to the desktop, select Settings from the Charms bar, then select Control Panel.*
3. In Network and Sharing Center, double-click the **Ethernet** link for the Ethernet connection you are using.
4. In the Ethernet Status dialog box, click **Properties**. *If this screen doesn't appear, just skip to Step 5.*
5. In the Ethernet Properties dialog box, on the **Networking** tab, select **Internet Protocol Version 4**, and then click **Properties**.
6. In the Internet Protocol Properties dialog box, select **Obtain an IP address automatically** and **Obtain DNS server address automatically** (see Figure 94). Then click **OK**.
7. In the Ethernet Properties dialog box, click **Close**.

Figure 94: Windows 8 - Internet Protocol Properties

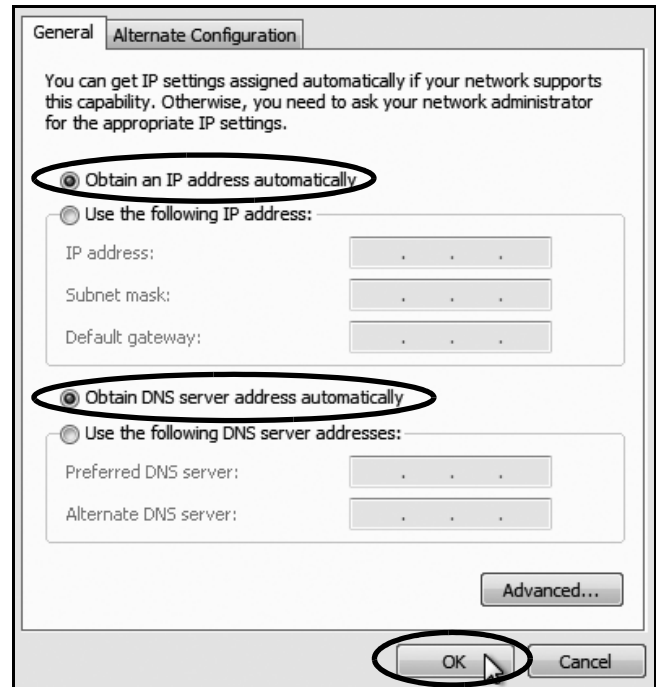

# C

# Continued Configuring Computers for DHCP

## Appendix

### Windows 7 or Windows Vista

1. Turn on the computer.
2. In Control Panel, double-click **Network and Sharing Center**. (You might need to click **Network and Internet** first.) *You can find the control panel either through the Start menu or "My Computer."*
3. In Network and Sharing Center, double-click the **Local Area Connection** link (Windows 7) or **View Status** link (Windows Vista) for the Ethernet connection you are using.
4. In the Local Area Connection Status dialog box, click **Properties**. *If this screen doesn't appear, just skip to Step 5.*
5. In the Local Area Connection Properties dialog box, click the **Networking** tab, select **Internet Protocol Version 4**, and then click **Properties**.
6. In the Internet Protocol Properties dialog box, select **Obtain an IP address automatically** and **Obtain DNS server address automatically** (see Figure 95). Then click **OK**.
7. In the Local Area Connection Properties dialog box, click **OK**.

Figure 95: Windows 7/Windows Vista- Internet Protocol Properties

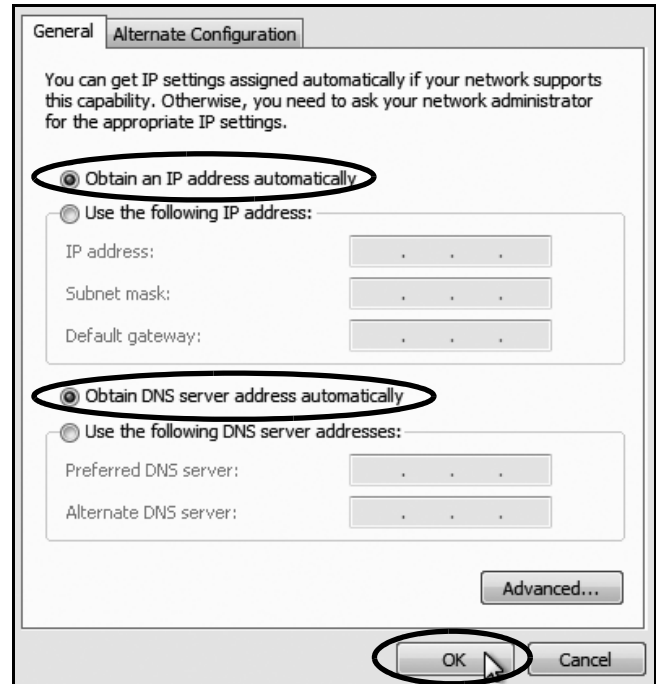

### Windows XP

1. Turn on the computer.
2. In Control Panel, double-click **Network Connections**. *You can find the control panel either through the Start menu or "My Computer."*
3. In Network Connections, double-click the **Local Area Connection** for the Ethernet connection you are using.
4. In the Local Area Connection Status dialog box, click the **General** tab. Then click **Properties**. *If this screen doesn't appear, just skip to Step 5.*
5. In the Local Area Connection Properties dialog box, click the **General** tab, select **Internet Protocol (TCP/IP)**, and then click **Properties**.
6. In the Internet Protocol (TCP/IP) Properties dialog box, click the **General** tab. Then select **Obtain an IP address automatically** and **Obtain DNS server address automatically** (see Figure 96). Then click **OK**.
7. In the Local Area Connection Properties dialog box, click **OK**.
8. Restart the computer.

Figure 96: Windows XP - Internet Protocol (TCP/IP) Properties

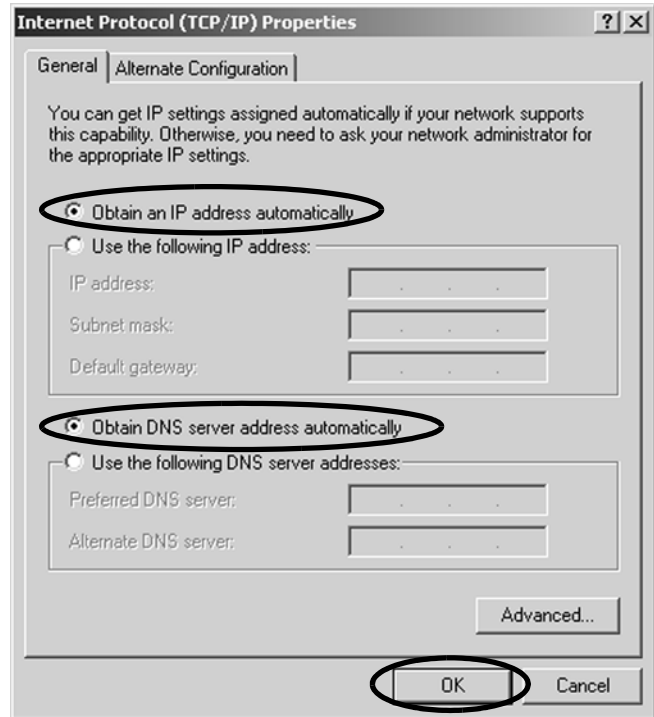

# C

# Continued Configuring Computers for DHCP

## Appendix

### Macintosh OS X

1. Turn on the computer.
2. In System Preferences, click **Network**.
3. In the Network dialog box, select **Ethernet** then set the following:
  - Location: **Automatic**
  - Configure IPv4: **Using DHCP**
4. Click **Apply**.
5. Restart the computer.

Figure 97: Macintosh OS X - Network Preferences

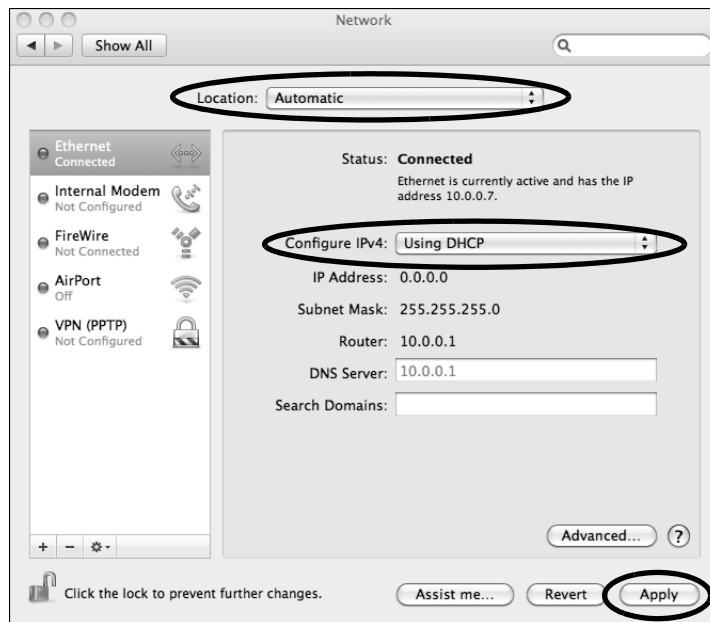

# D Verifying the NMEA 0183 Message

## Appendix

Verify the message supplied by the NMEA 0183 talker by connecting its output to a laptop using an RS422-to-USB adapter cable and viewing its data stream using PuTTY, HyperTerminal, or other terminal emulator. Follow the steps below to verify the message.

*NOTE: These example instructions assume you will be using PuTTY to enter antenna commands.*

1. Using an RS422-to-USB adapter, connect the NMEA 0183 talker to the adapter's RS422 input. Then connect the adapter to your laptop's USB port (see Figure 98).
2. Start PuTTY and specify your laptop's port, connection type, and baud rate (see Figure 99).
3. Configure options at the **Serial** configuration menu as follows (see Figure 100):
  - 4800 baud
  - 8 data bits
  - 1 stop bit
  - no parity
  - no flow control
4. Select **Open** to view the message data in a command line window (see Figure 101).

Figure 98: Connecting a NMEA 0183 Talker to a Laptop

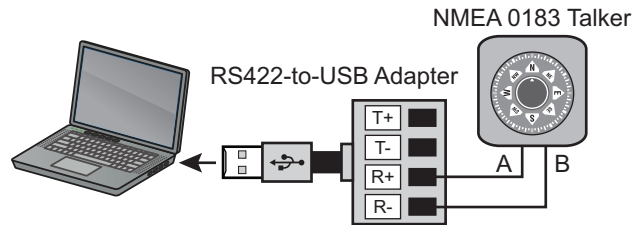

Figure 99: PuTTY Port Configuration Options (Example)

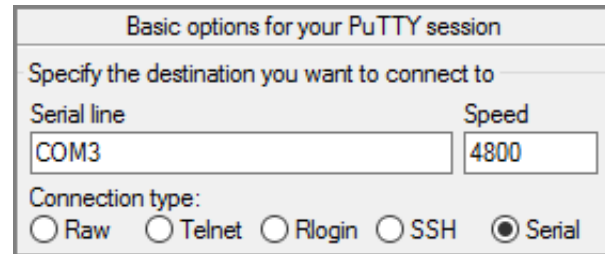

Figure 100: PuTTY Serial Configuration Options (Example)

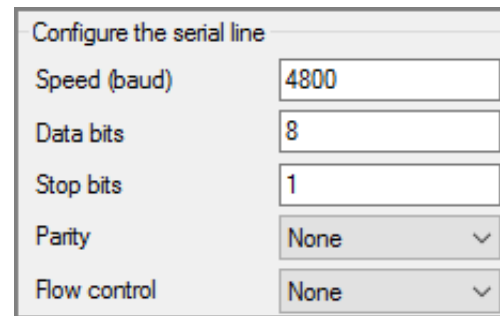
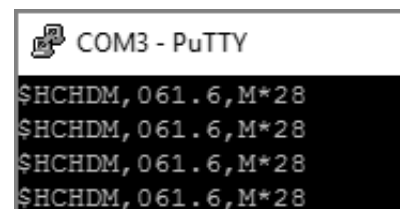
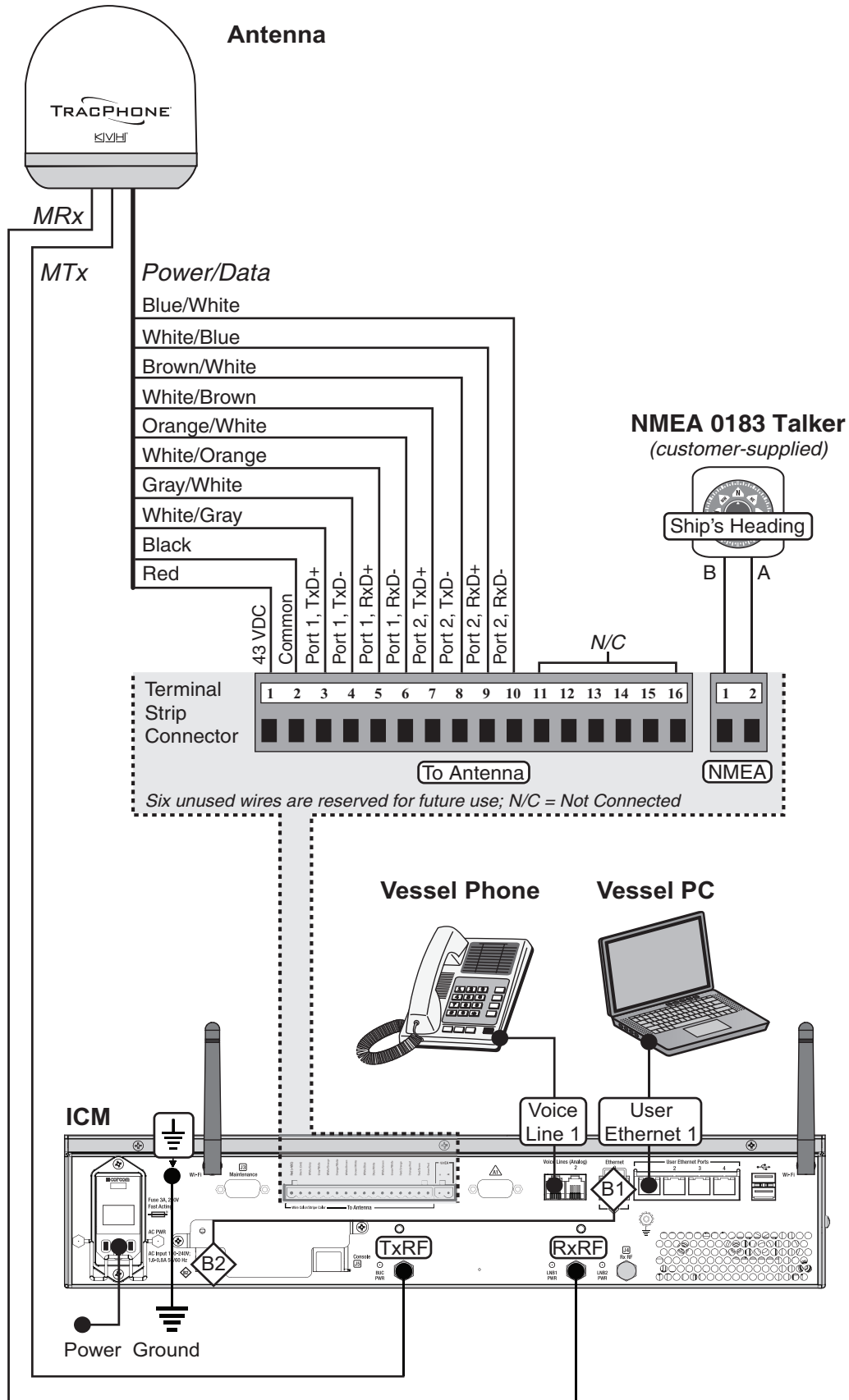

Figure 101: PuTTY Command Line Window (Example)



# E Wiring Diagram





## Regulatory Compliance

### European Union Compliance

Hereby, KVH Industries, Inc. declares that the radio equipment type TracPhone V3-HTS is in compliance with Directive 2014/53/EU. For the full text of the EU Declaration of Conformity, go to [www.kvh.com/euconformity](http://www.kvh.com/euconformity).

### Federal Communications Commission Compliance



The TracPhone system complies with Class B of Part 15 of the FCC (Federal Communications Commission) rules for radiated and conducted emissions.

FCC Identifiers: PPD-AR5B97 (ICM WiFi)

#### Use Conditions:

This device complies with part 15 of the FCC Rules. Operation is subject to the following two conditions:

1. This device may not cause harmful interference.
2. This device must accept any interference received, including interference that may cause undesired operation.

#### Note:

This equipment has been tested and found to comply with the limits for a Class B digital device, pursuant to Part 15 of the FCC Rules. These limits are designed to provide reasonable protection against harmful interference in a residential installation. This equipment generates, uses, and can radiate radio frequency energy and, if not installed and used in accordance with the instructions, may cause harmful interference to radio communications. However, there is no guarantee that interference will not occur in a particular installation. To determine if the equipment is interfering with radio or television reception, remove or apply power to the equipment and observe if the interference goes away, or returns, when the unit is off or on. The user is encouraged to try to correct the interference by one of the following measures:

- Reorient or relocate the receiving antenna.
- Increase the separation between the equipment and receiver.
- Connect the equipment into an outlet on a circuit different from that to which the receiver is connected.
- Consult KVH for assistance.

#### IMPORTANT:

- To meet FCC requirements, shielded Ethernet cables are required to connect the ICM to the ship's network.
- This equipment contains no user serviceable parts. Opening this unit will violate the warranty and may result in this equipment no longer complying with FCC requirements for Class B digital devices.

CE

UK  
CA



[www.kvh.com](http://www.kvh.com)



---

**KVH Industries A/S**  
*EMEA Headquarters*  
Kokkedal, Denmark  
Tel: +45 45 160 180 Fax: +45 45 160 181  
Email: [info@emea.kvh.com](mailto:info@emea.kvh.com)

**KVH Industries, Inc.**  
*World Headquarters*  
Middletown, RI U.S.A.  
Tel: +1 401 847 3327 Fax: +1 401 849 0045  
Email: [info@kvh.com](mailto:info@kvh.com)

**KVH Industries Pte Ltd.**  
*Asia-Pacific Headquarters*  
Singapore  
Tel: +65 6513 0290 Fax: +65 6472 3469  
Email: [info@apac.kvh.com](mailto:info@apac.kvh.com)