

**KVH Industries, Inc.**

# TracPhone® V11<sub>HTS</sub>



**Installation Guide**



# PLEASE READ!

## Important Addendum to the Installation Guide

### New RG-11 Cable Connectors

The Belden Snap N Seal connectors (SNS11AS), used to terminate RG-11 RF cables as described in your antenna installation manual, are no longer available. KVH has validated the PPC Belden-brand EX<sup>®</sup> series 11 universal compression cable connectors as a suitable replacement (see Figure 1).

#### **IMPORTANT!**

The EX series 11 universal connectors differ slightly from the Snap N Seal connectors, so it is critical that you follow the installation instructions provided at the manufacturer's website and watch the short video demonstration: <https://www.ppc-online.com/ex-series-7-11-compression-connectors>.

Be sure to adhere to the following steps, in particular:

1. After folding back your cable's braid, align the center conductor with the grooves on the new connector's body. Then mark the cable where it aligns with the base of the connector (see Figure 2).
2. Insert the cable into the connector. Then push firmly, while rotating clockwise, until the connector reaches the mark you made in step 1. The center conductor should protrude from the connector nut.

### New RG-11 Compression Tool

Prepare your cables with the tools provided in the RG-11 crimp tool kit (KVH part no. 72-0493) to ensure that the cables are stripped to the correct length for proper engagement between the cable and connector (see Figure 3). Use the Belden CST596711 cable stripper tool (KVH part no. 19-0719) to prepare your cables, then compress the connectors with the new VT200 compression tool (KVH part no. 19-1141-0200) (see Figure 4). When compression is complete, the center conductor should be rigid. If the pin can move in or out, cable performance may be degraded.

Figure 1: New EX Series 11 Connectors for RG-11



KVH Part No. 23-0917

Figure 2: Align the Cable With the Connector

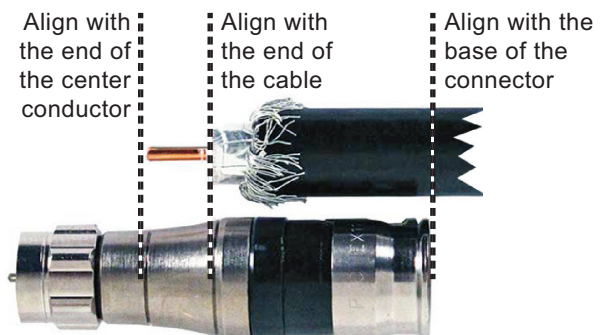

Figure 3: Cable Strip Lengths

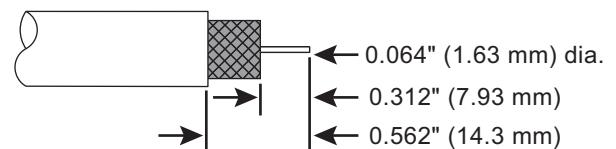

Figure 4: New Compression Tool



## Updated LMR-600 Connectors

The Times Microwave EZ-600-FMH-75 connectors, used to terminate LMR-600 cables as described in your antenna installation manual, have been replaced with the new functionally identical EZ-600-FM-75 connectors. The new connector version no longer requires that you trim the braid prior to securing the ferrule. Simply slide the ferrule over the braid, as you would have previously, to crimp the braid beneath the ferrule (see Figure 5).

Figure 5: New LMR-600-FM-75 “No Trim” Connector

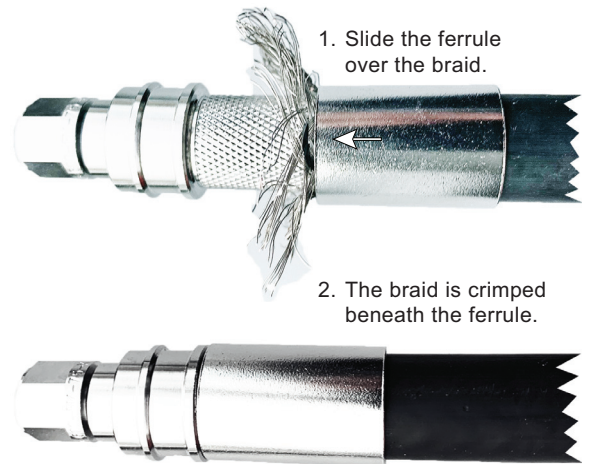



# PLEASE READ!

## Important Addendum to the Installation Guide

### Single Wi-Fi Antenna on ICM/ACU

The system's ICM/ACU now requires just a single Wi-Fi antenna. Connect the supplied Wi-Fi antenna to the Wi-Fi connector located next to the input power connector on the rear panel as shown here. The other Wi-Fi connector is no longer used.

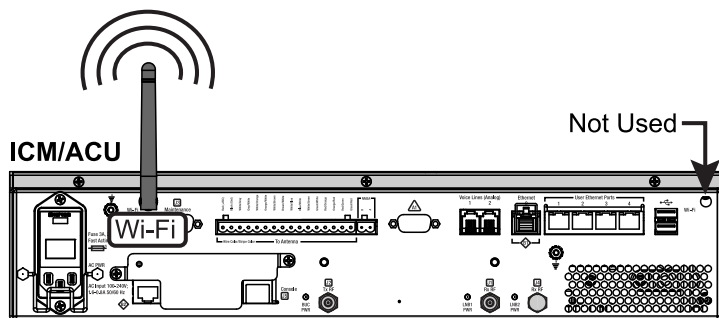

*NOTE: The new Wi-Fi module built into the ICM/ACU will provide the same performance with a single Wi-Fi antenna that two antennas provided with the previous version.*

# Please Read

## Important Addendum to Installation Guide



### New MTA Model for Adding KVH VoIP Lines

KVH is no longer selling the MTA model shown in the installation documentation (KVH part no. 19-0504), as it has been discontinued by the manufacturer. KVH is now selling a new, upgraded MTA model (KVH part no. 19-1191) (see Figure 1) as a drop-in replacement for the old model.

When connecting the new MTA model to the KVH below decks unit (BDU), refer to Figure 2 for an updated wiring diagram.

Figure 1: New MTA Model



Figure 2: New MTA Wiring Diagram

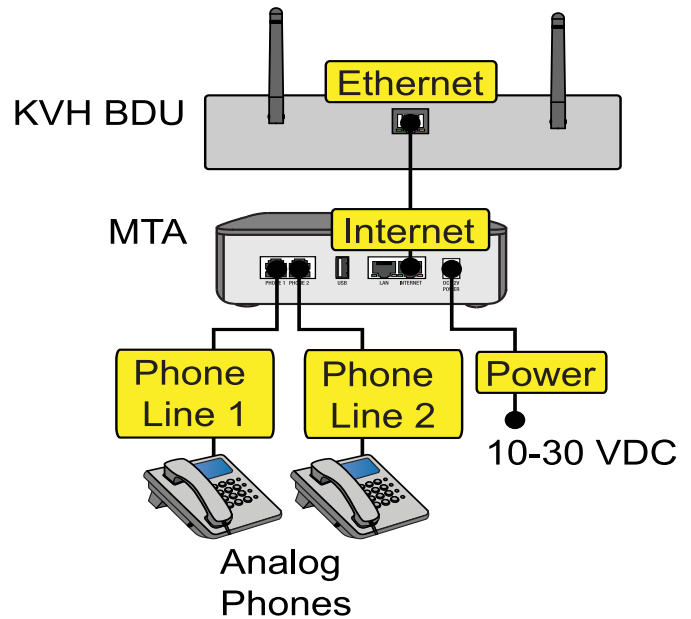

# TracPhone V11-HTS Installation Guide

## mini-VSAT Broadband™ System with Integrated CommBox™ Modem

This guide explains how to install the TracPhone V11-HTS mini-VSAT Broadband satellite communications system. Operation instructions are provided in the Quick Start Guide.

### Installation Steps

1. Inspect Parts and Get Tools .....	3	12. Connect Power .....	25
2. Plan the Antenna Installation .....	4	13. Turn On the System .....	27
3. Plan the ICM Installation.....	7	14. Update the System Software.....	28
4. Mount the ICM .....	8	15. Customize the Web Interface.....	29
5. Prepare the Antenna Site.....	9	16. Set Up No-Transmit Zones .....	30
6. Prepare the Antenna Cables .....	10	17. Commission the Modem .....	32
7. Rig and Hoist the Antenna.....	14	18. Test the System .....	33
8. Wire the Antenna .....	15	19. Configure the Network .....	34
9. Mount the Antenna .....	18	20. Connect Voice Line Equipment.....	40
10. Prepare the Data Cable .....	20	21. Educate the Customer.....	41
11. Wire the ICM.....	22		

### CAUTION - RF Radiation Hazard



The antenna transmits radio frequency (RF) energy that is potentially harmful. While the system is powered on, make sure everyone stays more than 42 feet (13 m) away from the antenna. As shown in the illustration, this distance increases to 101 feet (31 m) if a person is more than 6.5 ft (2 m) above the plane of the antenna's base.

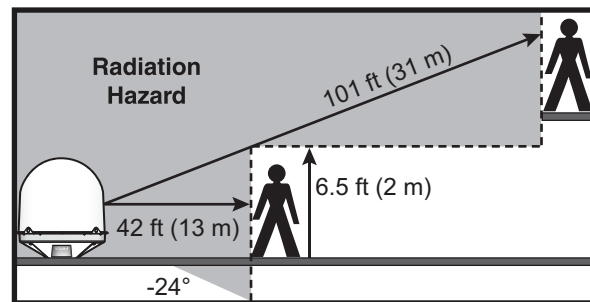

### Who Should Install the System?

To ensure a safe and effective installation, only a KVH-certified technician should install the TracPhone system. To find a technician near you, visit [www.kvh.com/wheretogetservice](http://www.kvh.com/wheretogetservice).

### Technical Support

**North/South America, Australasia:**

Phone: 1 866 701-7103 (*U.S. only*)

Phone: +1 401 851-3806

Email: [mvbsupport@kvh.com](mailto:mvbsupport@kvh.com)

**Europe, Middle East, Africa, Asia-Pacific:**

Phone: +45 45 160 180

Email: [mvbsupport@kvh.com](mailto:mvbsupport@kvh.com)

KVH, TracPhone, CommBox, and the unique light-colored dome with dark contrasting baseplate (Reg. No. 2,864,752) are trademarks, and mini-VSAT Broadband is a service mark, of KVH Industries, Inc. All other trademarks are property of their respective companies.

The information in this document is subject to change without notice. No company shall be liable for errors contained herein.

TracPhone V11-HTS is protected by U.S. patents #8,866,564, #9,520,637, and #9,966,648.

©2019-2025 KVH Industries, Inc., All rights reserved. **54-1289 Rev. E**

# Important Safety Information

---

Be sure to read these warning and caution notices carefully to avoid injury.



## **WARNING** Risk of Electric Shock

Potentially lethal voltages are present within the antenna and the ICM when the system is connected to AC power. To avoid electric shock, do not enter the antenna's hatch or remove the radome while the system is powered on. Also do not open the ICM chassis enclosure for any reason; there are no user-serviceable parts inside.



## **WARNING** Risk of Electric Shock

If any component of the TracPhone system becomes damaged and/or no longer functions normally, disconnect it from vessel power, secure it from unintended operation, and contact KVH Technical Support (see "Technical Support" on page 1). All repairs or modifications must be performed by a trained, KVH-certified technician. If you are a KVH-certified technician, you still must contact KVH Technical Support prior to conducting any repairs or modifications to the equipment.



## **WARNING** Risk of Explosion

Do not operate the ICM (or any other electrical device) in an environment where flammable gases, vapors, or dusts are present. In addition, do not operate the ICM in an environment with a temperature outside its 5° F to 131° F (-15° C to 55° C) temperature range.



## **WARNING** Risk of Electric Shock

Failure to ground the TracPhone system properly to ship's ground will cause an unsafe floating ground condition, risking potentially lethal electric shock. See "Connect Power" on page 25 for details on the proper grounding of the equipment.



## **CAUTION** RF Radiation Hazard

The antenna transmits up to 22 watts of radio frequency (RF) energy that is potentially harmful. Whenever the system is powered on, make sure everyone stays more than 42 feet (13 m) away from the antenna. The minimum safe distance increases to 101 feet (31 m) if a person is more than 6.5 feet (2 m) above the plane of the antenna's base. No hazard exists directly below the antenna.



## **CAUTION** Crushing Hazard

The antenna contains moving parts that can cause injury. Do not enter the hatch while the system is connected to AC power.

# 1 Inspect Parts and Get Tools

Before you begin, follow these steps to make sure you have everything you need for installation.

- a. Unpack the box and ensure it contains everything shown in Figure 1 and on the *Kitpack Contents List*. Save the packaging.
- b. Carefully examine all of the supplied parts to ensure nothing was damaged in shipment.
- c. Gather all of the following tools and materials that you will need:
  - Flat-head and Phillips-head screwdrivers
  - Electric drill and 5/8" (16 mm) bit
  - 3.75" (95 mm) hole saw (for cable access hole, if needed)
  - 5/32" hex key
  - 7/16" open-end torque wrench set to 20 in.-lbs (2.25 N-m)
  - 1/2" open-end wrench
  - 3/4" socket/ratchet or wrench
  - 1/4" socket/ratchet or nut driver
  - 7/16" socket/ratchet or nut driver
  - 3/4" socket/torque ratchet capable of settings between 35 and 40 ft-lbs (47 and 54 N-m) of torque
  - Light hammer and center punch
  - Adhesive tape
  - Eye protection
  - Shop towels
  - Silicone sealant, self-vulcanizing tape, or equivalent
  - Two 75Ω RF coax cables, "F" connectors, and termination tools (see page 10)
  - Power cable (see page 12)
  - Heat gun (for heat shrink)
  - Wire stripper/terminal crimper
  - Forehead light

Figure 1: TracPhone V11-HTS System Components

## Antenna

(KVH part no. 02-1982-04)

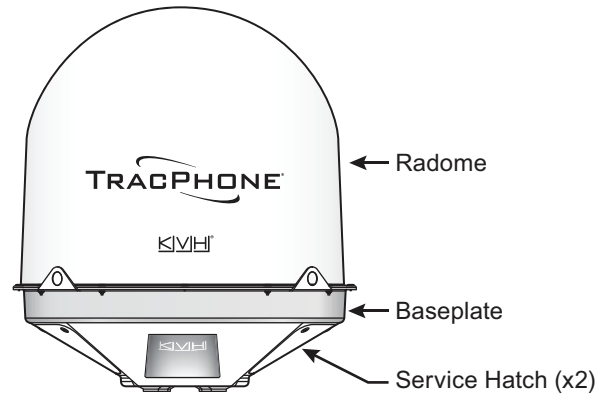

## Integrated CommBox Modem (ICM)

(KVH part no. 02-2204-03)

- NMEA 0183 talker and interface cable (see page 23)
- RS422-to-USB adapter
- Isolation transformer, if required (see page 25)
- Utility knife
- Flush cutters
- File
- Ruler or tape measure
- Voltmeter
- Laptop PC with the latest TracPhone V11-HTS ICM/antenna software downloaded from the KVH Partner Portal ([www.kvh.com/partners](http://www.kvh.com/partners))

# 2 Plan the Antenna Installation

Before you begin, consider the following antenna installation guidelines.

## Choose a Suitable Location

- Select a location that is as close as possible to the intersection of the vessel's centerline and midships.
- Both service hatches should be fully accessible for installation and service.
- Temperature must be within the operating range (-30°C to 55°C (-22°F to 131°F)).
- Avoid placing the antenna near any magnetic compasses or other onboard antennas to prevent potential interference.

## Meet Mounting Structure Requirements

If available, install the antenna on a platform or pedestal, rather than on a deck, and ensure the diameter of the mounting surface matches the antenna's base (19.01" (48.29 cm)) (see Figure 2).

Make sure the mounting surface is flat and level (within  $\pm 1^\circ$ ). Also make sure the mounting structure is strong enough to withstand the weight of the antenna (240 lbs (109 kg), excluding cables) as well as other cumulative forces related to expected operating conditions, such as ice, snow, wash down, and maximum expected values of pitch, roll, and wind pressure (including gusts).

Vibration of the mounting surface should measure less than 0.51 gRMS total, and also less than 0.11 gRMS at the following resonant frequencies and axes:

- 14.93 Hz and 60.89 Hz in Horizontal Forward X-Direction
- 16.07 Hz and 71.02 Hz in Horizontal Side Y-Direction
- 37.7 Hz and 79.89 Hz in Vertical Z-Direction

Please consult with your shipyard to assure that the antenna mounting surface vibration never exceeds the above stated conditions at any time during its life.

Figure 2: Antenna Dimensions

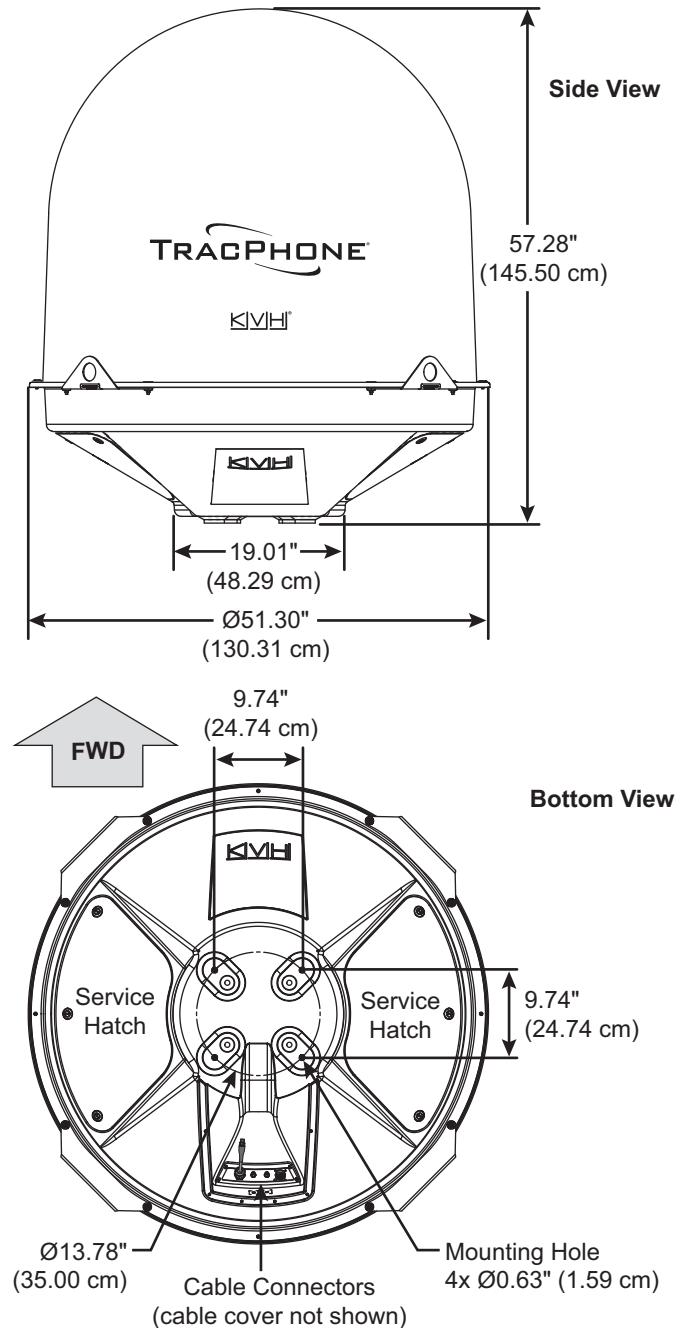

# 2

## Continued Plan the Antenna Installation

### Meet Pedestal Structure Requirements

If a pedestal is going to be used, it must meet the following minimum requirements. Refer to Figure 3.

<b>Pedestal Height (A)</b>	3.28 ft 1 m	6.56 ft 2 m	9.84 ft 3 m
<b>Tube OD (B)</b>	9.0" 230 mm	8.0" 203.2 mm	10.0" 254 mm
<b>Tube Wall Thickness (C)</b>	0.5" 12.7 mm		
<b>Brace Height (D)</b>	N/A	5.56 ft 1.7 m	7.34 ft 2.24 m
<b>Brace OD (E)</b>	N/A	3.0" 76.2 mm	6.0" 152.4 mm
<b>Brace Thickness (F)</b>	N/A	0.25" 6.35 mm	0.5" 12.7 mm
<b>Brace Angle (G)</b>	N/A	30°	25°

**NOTE:** If the pedestal exceeds 3.28 ft (1 m), braces must be placed at 120° intervals. Sizing is based on Structural Steel Tubing 60,000 psi (415 MPa) minimum yield. For more details, refer to the Antenna Pedestal Specs Wizard (go to [www.koh.com/pedestalspecs](http://www.koh.com/pedestalspecs)).

Figure 3: Pedestal and Brace Dimensions

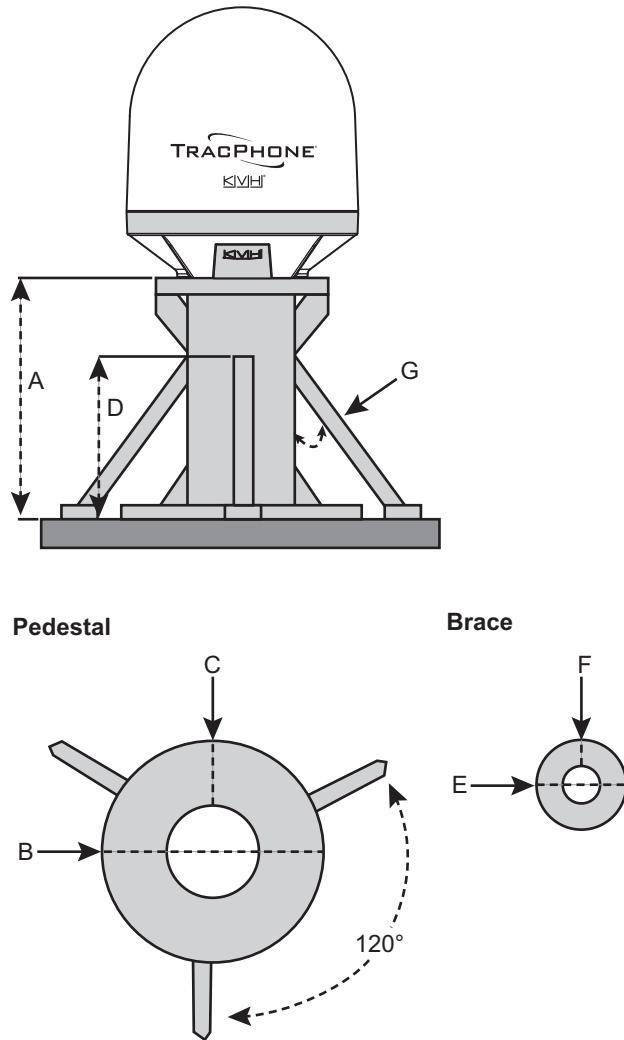

# 2 Continued Plan the Antenna Installation

## Prevent RF Radiation Exposure

Select a location that is well above any areas accessible to passengers and crew to reduce the risk of RF radiation exposure. (See page 1 for an illustration of the hazard area.)

If mounting the antenna near an accessible area is unavoidable, you may configure one or two no-transmit zones to prevent transmissions in hazardous directions. (See “Set Up No-Transmit Zones” on page 30 for details.)

## Minimize Satellite Blockage

The antenna requires a clear view of the sky to transmit and receive satellite signals (see Figure 4). The fewer obstructions, the better the system will perform.

## Avoid RF Interference

Although many variables determine the exact distance required between the antenna and radar/high-power radio transmitters, including transmitter beam properties and the reflective properties of nearby surfaces, consider the following general requirements when selecting a safe antenna location:

### IMPORTANT!

RF emissions from radars and high-power radio transmitters may damage the antenna or impair its performance if it's improperly positioned within the beam path.

- Mount the antenna as far away as possible from the radar and any high-power radio transmitters.
- The minimum safe distance and vertical separation between the antenna and the radar varies depending on the type and power level of the radar. Using the table in Figure 5, mount the antenna at least the minimum distance away from the radar and maintain at least the minimum vertical separation above/below the radar. **If mounting the antenna directly above or below the radar, minimum distance is 3 ft (0.9 m).**

Figure 4: Blockage from Obstruction

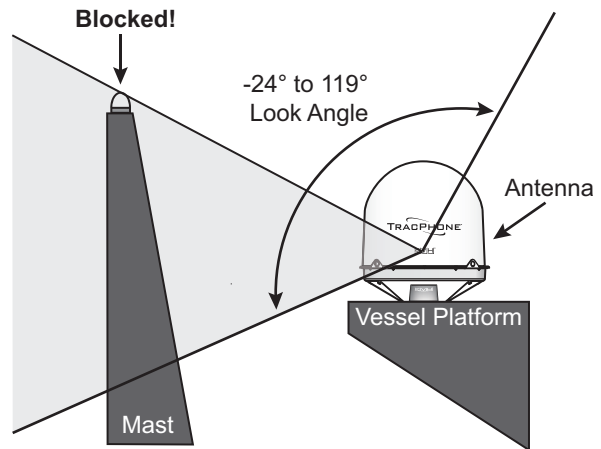
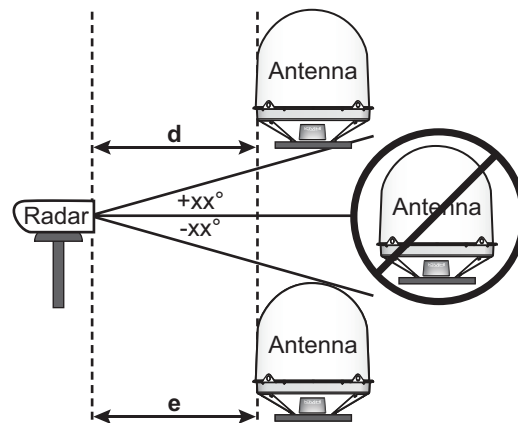

Figure 5: Minimum Distances from Radar



Radar Type	Radar Power	Minimum vertical separation ( $\pm xx^\circ$ )	Minimum distance away (d or e)
X-band	Up to 50 KW	$\pm 15^\circ$	3 ft (0.9 m)
S-band	Up to 10 KW	$\pm 20^\circ$	6 ft (2 m)
	30 KW	$\pm 30^\circ$	9 ft (3 m)
	50 KW	$\pm 30^\circ$	14 ft (4.5 m)

# 3 Plan the ICM Installation

Before you begin, consider the following installation guidelines for the ICM.

- Select a mounting location in a dry, well-ventilated area belowdecks away from any heat sources or salt spray.
- Temperature must be within the operating range (-15°C to 55°C (5°F to 131°F)).
- Be sure the front panel will be easily accessible to the user.
- Leave enough room at the rear panel to accommodate the connecting cables.
- To use the supplied power/data cable, the ICM must be located within 100 ft (30 m) of the antenna. However, you can order a longer cable run if necessary.
- Be sure the location provides adequate Wi-Fi reception. Do not install it in an area surrounded by metal or near any electrical devices that emit RF noise.

Figure 6: ICM Dimensions

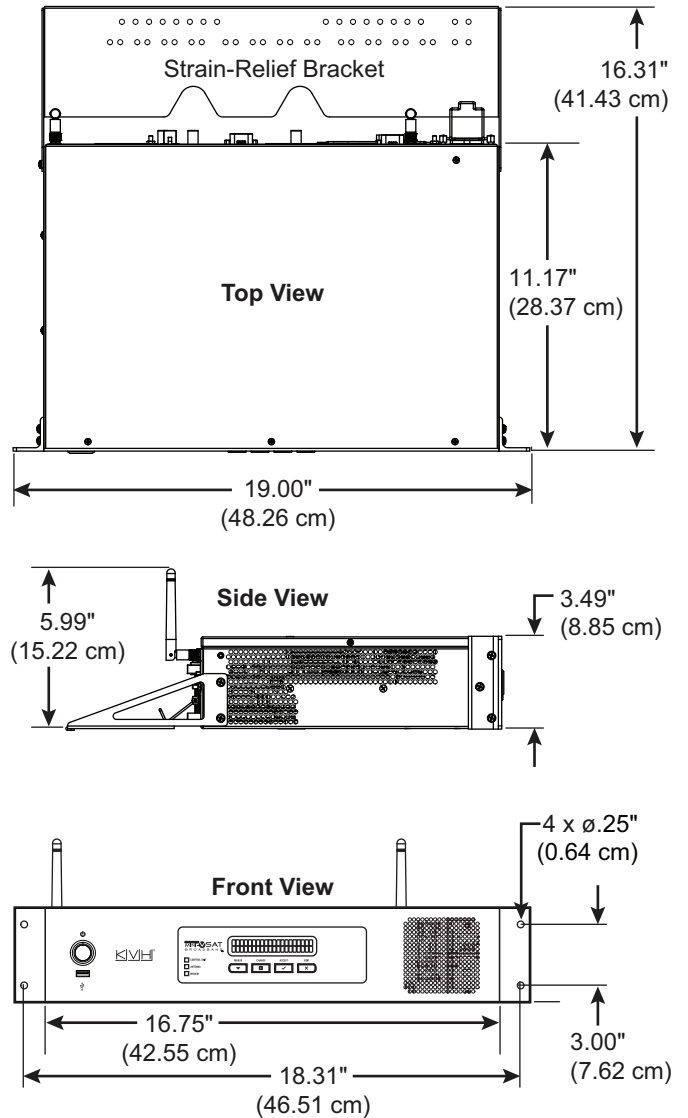

# 4 Mount the ICM

There are two options for mounting the ICM:

**Option 1** - Inside an equipment rack

**Option 2** - To a horizontal surface

*NOTE: You may choose to wait to mount the ICM until after you have completed all system wiring.*

## Option 1 – Rack Mount

The ICM is sized to fit a standard 19" (48.26 cm) rack, occupying 2U of space. Follow these steps to secure the ICM in an equipment rack.

- a. Attach the supplied strain-relief bracket to the back of the ICM using four supplied #6-32 screws and washers (see Figure 7).
- b. Insert the ICM into the rack and secure its front mounting brackets to the rack using four M6 screws and washers (see Figure 8).

## Option 2 – Horizontal Surface Mount

Follow these steps to mount the ICM to a horizontal surface.

- a. Remove the six #6-32 screws and washers securing the two rack-mount brackets to the front of the ICM (see Figure 9). Remove the brackets.
- b. Attach the supplied strain-relief bracket to the back of the ICM, and attach the supplied "L" mounting brackets to the sides of the ICM, using six supplied #6-32 screws and washers (see Figure 10).
- c. Mount the ICM to the vessel using fasteners appropriate for the mounting surface.

Figure 7: Attaching the Strain-Relief Bracket

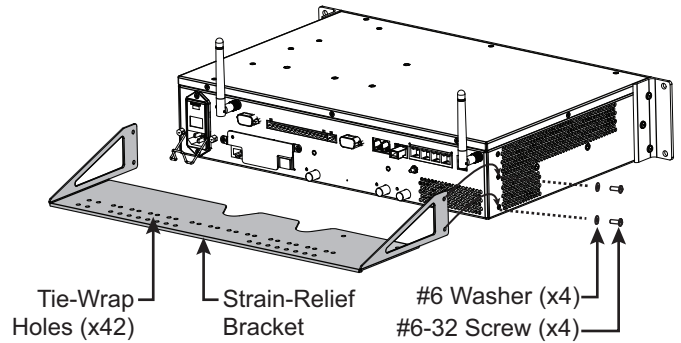

Figure 8: Securing the ICM in the Rack

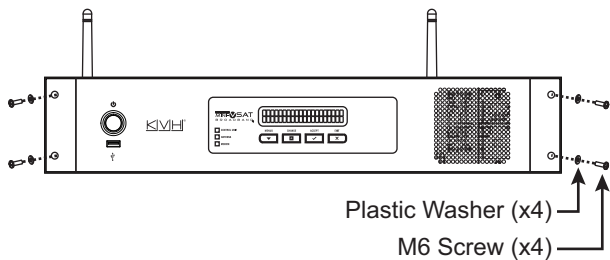

Figure 9: Removing the Rack-Mount Brackets

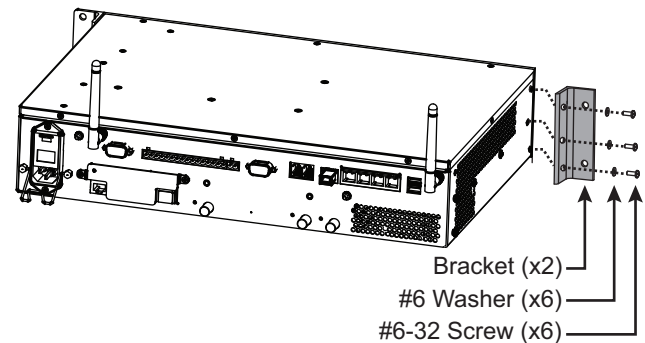
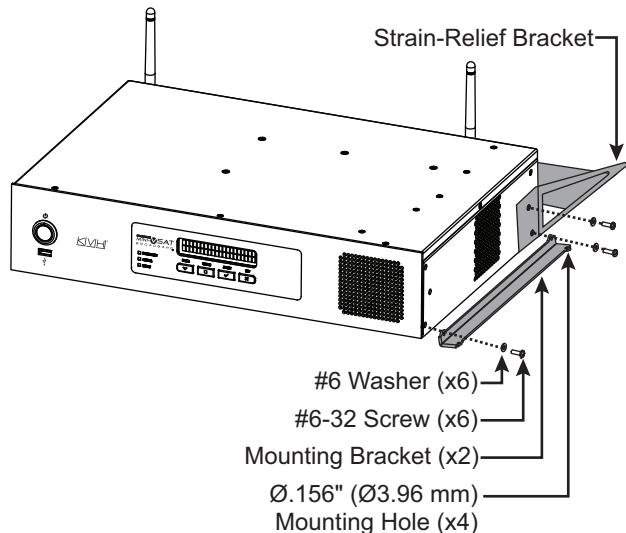

Figure 10: Attaching the Mounting and Strain-Relief Brackets



# 5 Prepare the Antenna Site

Once you have identified a suitable antenna mounting site, follow these steps to prepare the site for installation.

## Drill the Mounting Holes

- Unfold the antenna mounting template (supplied in the Customer Welcome Kit) and place it onto the mounting surface. Make sure the "FWD" (forward) arrow points toward the bow and is parallel to the vessel's centerline (see Figure 11).

**NOTE:** You don't need to mount the antenna exactly on the vessel's centerline, but the antenna's forward arrow must be parallel to it.

- Using a light hammer and center punch, mark the locations for the four mounting holes on the mounting surface in the locations indicated on the template.
- Drill a 5/8" (16 mm) hole at the four mounting hole locations. Later, you will insert four 1/2"-13 bolts through these holes to mount the antenna.

## Cut Out the Cable Access Hole, If Needed

If you plan to route the antenna cables belowdecks through a hole directly underneath the antenna, follow the steps below.

- Using the supplied template, mark the location of the cable access hole in the center of the mounting hole pattern (see Figure 11).
- Cut out the 3.75" (95 mm) cable access hole in the location you marked in Step a. Smooth the edges of the hole to protect the cables. (You may also apply anti-chafe material around the cables to prevent abrasion.)
- Clean and dry the antenna mounting surface.
- Peel off the paper backing from one of the supplied foam seals to expose the adhesive. Then press the foam seal down firmly onto the mounting surface, ensuring the hole in the foam seal aligns with the cable access hole in the mounting surface (see Figure 11).

Figure 11: Antenna Mounting Holes Layout

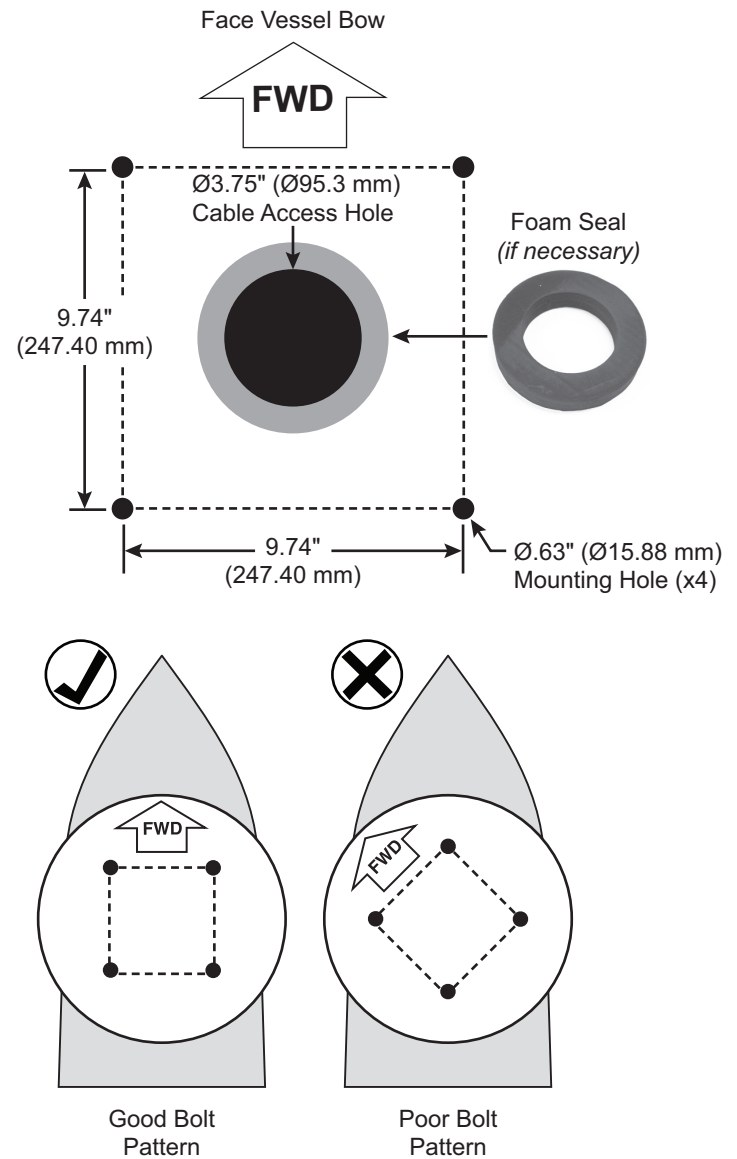

# 6 Prepare the Antenna Cables

Follow these steps to prepare and route the RF, power, and data cables to the antenna location.

## Prepare the Customer's RF Cables

You need to connect two 75Ω RF coax cables from the antenna location to the ICM. Refer to Figure 12 to determine the type of cables and connectors you can use for your cable run. Then prepare the cables as described below.

### IMPORTANT!

- If you use RG-11 RF cables 80-100 ft (25-30 m) in length, you can avoid the modem commissioning step. See “Commission the Modem” on page 32.
- RF cables must be rated for 75Ω, not 50Ω.
- Low-quality, poorly terminated, or improperly installed RF cables are the most common cause of system problems. Terminate all RF cables with high-quality “F” connectors using the proper stripping/crimping tools, exactly to the manufacturer’s specifications. See page 48 for instructions on terminating LMR cables.
- Do not use RG-6 cable, as it will damage the system. Use of any cables not specified in Figure 12 will void the warranty.
- Make sure the center conductor pin at each end of the finished cables is free of burrs and 1/4" (0.20"-0.28") (5-7 mm) in length, measured from inside the nut to the tip, to ensure proper engagement.
- (LMR cables only) Make sure there is no gap between the end of the cable jacket and the start of the connector.
- When determining cable lengths, don’t forget to account for service loops, 14" (35 cm) in diameter, at each end.

Figure 12: RF Cable Options

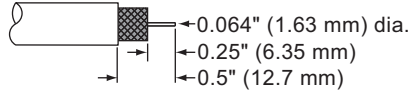
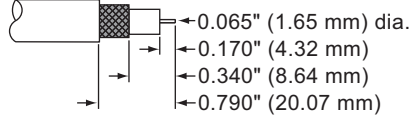
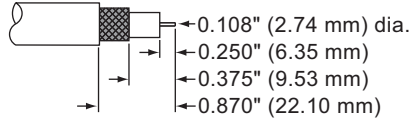
RG-11	
Max. length	100 ft (30 m)
KVH part no.	50 ft (15 m): S32-0566-50 100 ft (30 m): S32-0566-0100
Connector	Belden SNS11AS*
Tools	Belden CST596711, L3011B (KVH part no. 72-0493)
Strip lengths	
LMR-400-75	
Max. length	200 ft (60 m)
KVH part no.	100 ft (30 m): S32-0944-0100 150 ft (45 m): S32-0944-0150 200 ft (60 m): S32-0944-0200
Connector	Times Microwave EZ-400-FMH-75*
Tools	Times Microwave TK-400EZ-75 (KVH part no. 72-0374-75**)
Strip lengths	
LMR-600-75	
Max. length	325 ft (100 m)
KVH part no.	150 ft (45 m): S32-0945-0150 200 ft (60 m): S32-0945-0200 300 ft (90 m): S32-0945-0300
Connector	Times Microwave EZ-600-FMH-75*
Tools	Times Microwave TK-600EZ (KVH part no. 72-0375-75**)
Strip lengths	

\* Cables from KVH include the proper connectors.

\*\* LMR tool kits from KVH include a torque wrench.

# 6 Continued Prepare the Antenna Cables

## Connect the Customer's RF Cables to the Supplied Pigtail Cables

### IMPORTANT!

Use of the supplied pigtail cables is **mandatory**. Do not connect the customer's RF cables directly to the antenna.

- a. Clean and dry the RF cables' connectors.
- b. **Label both ends** of the customer's RF cables. Label one cable "TX," and label the other "RX."
- c. Heat shrink is supplied with each 3 ft (90 cm) pigtail cable to protect the connection between the customer's RF cables and the pigtail cables. Slide a heat shrink sleeve onto the end of each 3 ft (90 cm) pigtail cable (opposite the boot end) for later use.
- d. Fill half of the inner body of the customer's "TX" RF cable's connector with the supplied silicone grease to prevent moisture and corrosion.
- e. Connect and **SLOWLY** hand-tighten the "TX" RF cable to the feed-thru adapter of one of the supplied LMR-400-75 pigtail cables, allowing the grease to diffuse and settle into the entire space within the connector (see Figure 13).
- f. Make sure the RF cable's connector is tightened all the way into the pigtail cable's feed-thru adapter. Then tighten it with a 7/16" torque wrench set to 20 in.-lbs.
- g. Seal the RF cable-to-pigtail connection using silicone sealant, self-vulcanizing tape, or equivalent. Then protect the connection with the heat shrink (see step c).
- h. Repeat steps d-g to connect the "RX" RF cable to the other pigtail cable.

Figure 13: Connecting the Pigtail Cables to the RF Cables

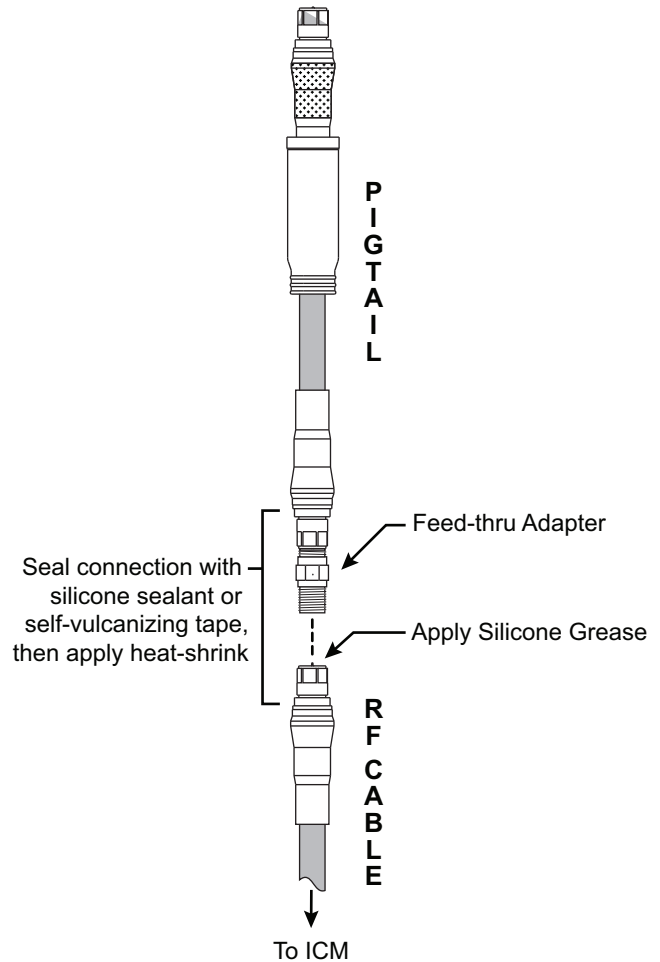

# 6 Continued Prepare the Antenna Cables

## Prepare the Customer's Power Cable

You will need to connect a power cable from the antenna to the vessel's 100-240 VAC power supply. The cable must be an above deck, marine-grade, 3-conductor, stranded (*flexible, bend radius of at least 3" (8 cm)*) power cable suitable for carrying 500 watts AC power to the antenna with less than a 5% voltage drop across its length. Refer to Figure 14 for the suggested cable gauge for your cable run.

### IMPORTANT!

Be sure to comply with all applicable electrical codes and safety standards for the vessel's country of origin and vessel type.

Follow these steps to attach the supplied AC power connector to the end of your power cable. This female connector mates with the male connector at the antenna.

- Pass the end of the power cable through the connector's nut and housing as shown in Figure 15.
- Strip the jacket from the end of the power cable  $7/8"$  (22.2 mm). Then strip back the insulation of all three wires between  $1/4"$  (6 mm) and  $5/16"$  (8 mm).
- Connect the wires to the connector as shown in Figure 15.
- Slide the housing over the connector and snap it into place.
- Tighten the nut onto the end of the housing. Tighten to approximately 3 ft-lbs (4 N-m) of torque.

Figure 14: Power Cable Recommendations

Cable Length	Suggested Gauge
Up to 100 ft (30 m)	14 AWG
101-300 ft (31-90 m)	12 AWG

Figure 15: AC Power Cable Connector

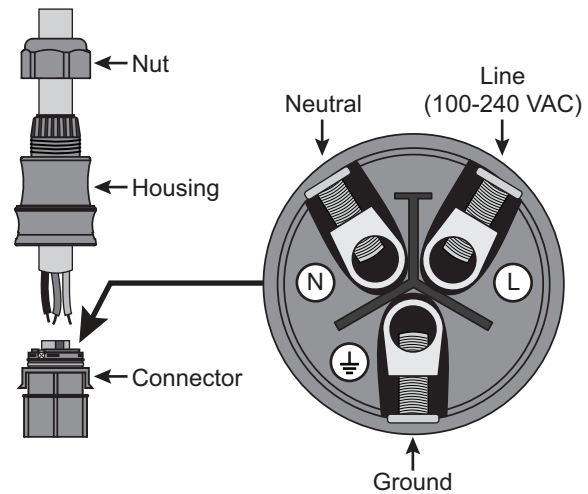

# 6 Continued Prepare the Antenna Cables

## Route the Cables Belowdecks

- Keep the ends of the data, power, and RF cables shown in Figure 16 at the antenna location.
- Route the opposite ends of the cables belowdecks through the cable access hole. Leave an adequate service loop, at least 14" (35 cm) in diameter, in all of the cables at the antenna location for easy serviceability. (Total extra length of RF cables should not exceed 6.5 ft (2 m) at each end.)
- Route the cables to the belowdecks equipment. Be sure to always maintain the minimum bend radius in the RF cables (see Figure 17). Later, you will connect the data and RF cables to the ICM, and the power cable to the vessel's AC power supply.

Figure 16: Cables Ready to Connect to Antenna

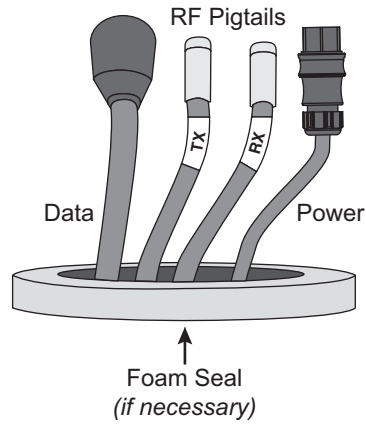

Figure 17: Minimum Bend Radius of RF Cables

**WARNING**

Do not connect the power cable to vessel AC power yet. You will connect power in Step 12 on page 25.

Cable Type	Minimum Bend Radius
RG-11	4.5" (11.5 cm)
LMR-400-75	4.5" (11.5 cm)
LMR-600-75	6" (15.3 cm)

# 7 Rig and Hoist the Antenna

Follow these steps to detach the antenna from the pallet and safely rig the antenna for crane hoisting.

**IMPORTANT!**

Take protective measures to avoid gouging or scratching the radome during the rigging operation.

- a. Using a 7/16" socket/ratchet or nut driver, unlock the three hex latches securing each of the antenna's service hatches (see Figure 18). Then gently lower the hatches. You can now access the four shipping bolts securing the antenna's baseplate to the pallet.
- b. Using a 3/4" socket/ratchet or wrench, remove the four outer 1/2"-13 bolts securing the antenna to the pallet (see Figure 19). Do not remove the four inner bolts that secure the internal antenna assembly to the baseplate.
- c. Close both antenna service hatches. Secure each hatch using the three hex latches.
- d. Secure the crane rigging to the antenna's four lift brackets (see Figure 20). Be sure the rigging and crane are suitably rated to safely lift the 240 lbs (109 kg) antenna.



**WARNING**

Be sure no personnel stand underneath the antenna at any time while it is suspended in the air.

- e. Carefully hoist the antenna to its mounting location.

Figure 18: Service Hatches

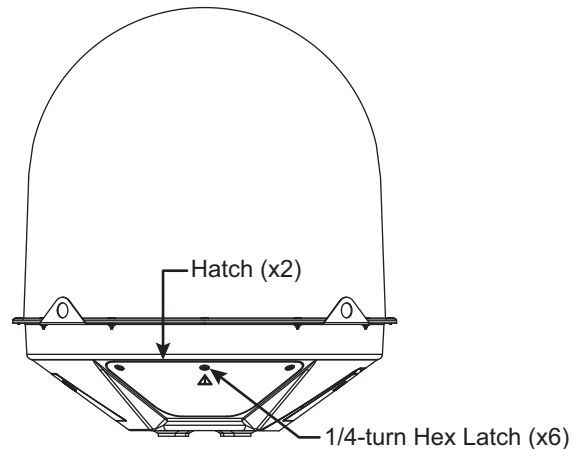

Figure 19: Shipping Bolts (Antenna Bottom View)

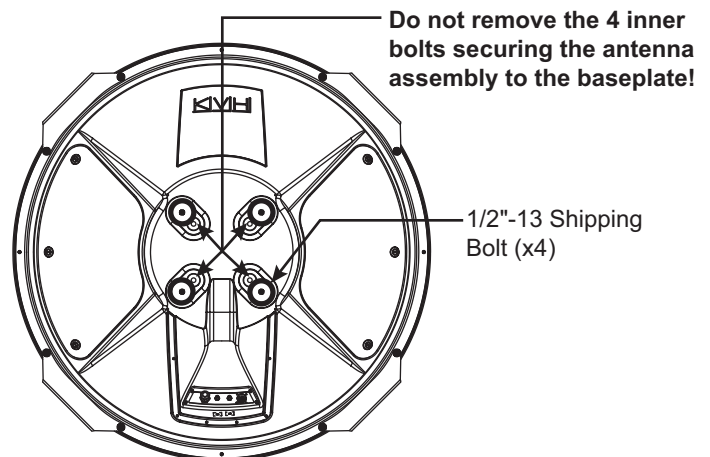
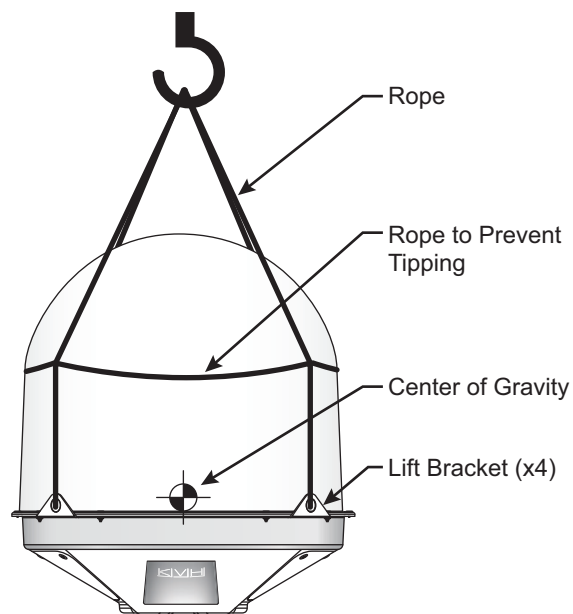

Figure 20: Crane Rigging (Example)



# 8 Wire the Antenna

Follow these steps to connect the antenna cables.

## Remove the Cable Cover

To access the antenna's connectors, you first need to detach the cable cover. Loosen the six #6-32 captive screws securing the cable cover to the base (see Figure 21). Then set the cable cover aside in a safe place.

## Attach the Second Foam Seal, If Needed

If you routed the cables through a hole directly underneath the antenna (see "Cut Out the Cable Access Hole, If Needed" on page 9), follow these steps to attach the second foam seal to the base of the antenna.

- a. Clean and dry the bottom of the antenna.
- b. Peel off the paper backing from the second foam seal to expose the adhesive. Align the foam seal so it is centered on the antenna (see Figure 22). Then press the foam seal firmly onto the underside of the antenna.

Figure 21: Cable Cover

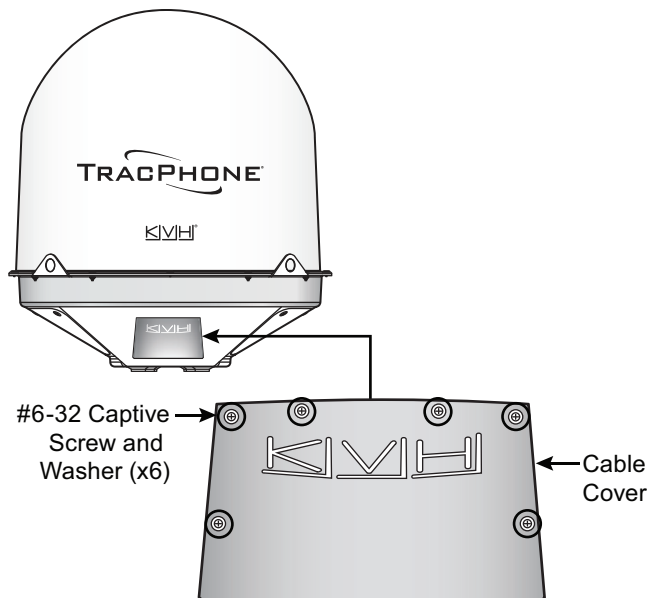
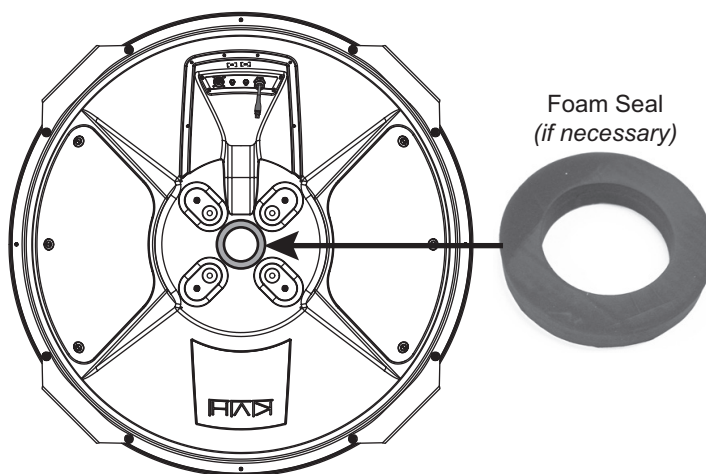

Figure 22: Foam Seal on Base of Antenna



# 8 Continued Wire the Antenna

## Connect the RF Pigtail Cables

- Clean and dry the antenna's two RF connectors, labeled "MTX" and "MRX" (see Figure 23).
- Place one of the supplied rubber connector washers over the "MTX" jack on the bottom of the antenna, as shown in Figure 24.
- Fill half of the inner body of the "TX" pigtail cable's male connector with silicone grease.
- Connect and **SLOWLY** hand-tighten the "TX" pigtail cable to the antenna's "MTX" jack, allowing the grease to diffuse and settle into the entire space within the connector.
- Make sure the "TX" pigtail cable's connector is tightened all the way into the antenna's connector and the rubber washer is compressed against the antenna's base. Then tighten the connector with a 7/16" torque wrench set to 20 in.-lbs.
- Apply a thin layer of silicone grease to the jacket of the "TX" pigtail cable, along the wider segment at the base of the connector.
- Slide the rubber boot up the cable until it covers the entire connector and mates with the rubber washer. This will protect the connection from the elements.
- Wipe off any excess grease from the cable.
- Repeat steps b-h to connect the "RX" pigtail cable to the antenna.

## Connect the Data Cable

Connect the data cable to the "Data" jack on the base of the antenna (see Figure 23). Hand-tighten until the connector locks in place; do not use excessive force.

## Connect the Power Cable

Connect the customer's power cable to the AC power pigtail cable on the base of the antenna (see Figure 23). Be sure the connector locks in place.

Figure 23: Antenna Connectors

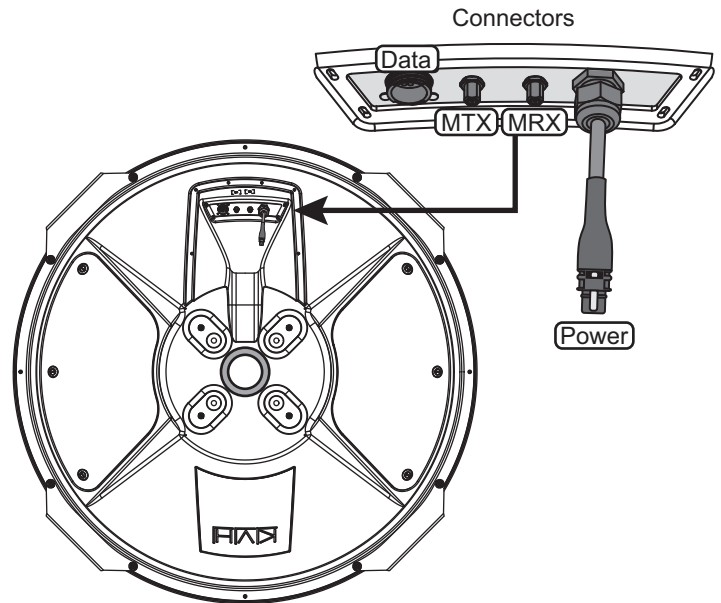
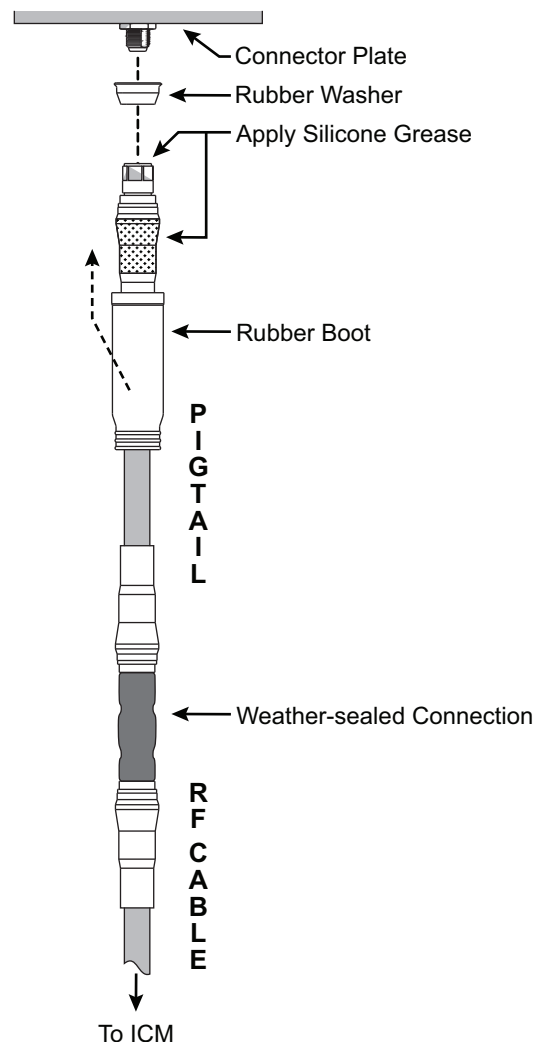

Figure 24: Connecting the RF Pigtail Cables to the Antenna



# 8 Continued Wire the Antenna

## Protect the Cables

- Position the cable cover over the antenna's cable connectors and secure in place with the six #6-32 captive screws and washers (see Figure 25).
- Secure the cables near the antenna connectors to relieve stress (such as the example in Figure 26). The cable cover is designed for aesthetics only – it does not provide any support for the cables and may become damaged if cables are not properly strain-relieved.
- Weatherproof and seal the cable access hole, as required.

### **IMPORTANT!**

The integrity and reliability of the RF cables is critically important. Make certain that these cables are properly terminated, sealed against seawater and corrosion, strain-relieved, protected from abrasion, and free of stress.

Figure 25: Cable Cover

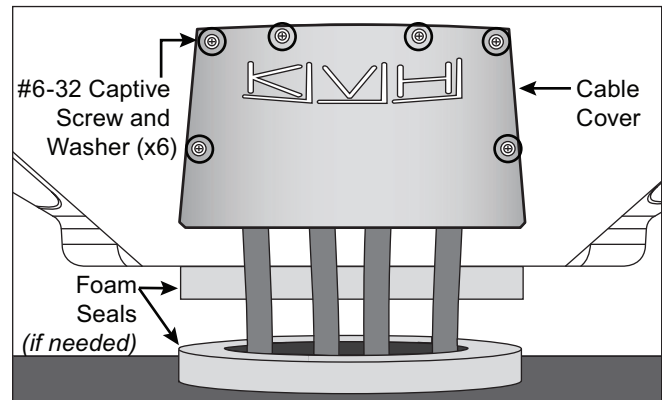
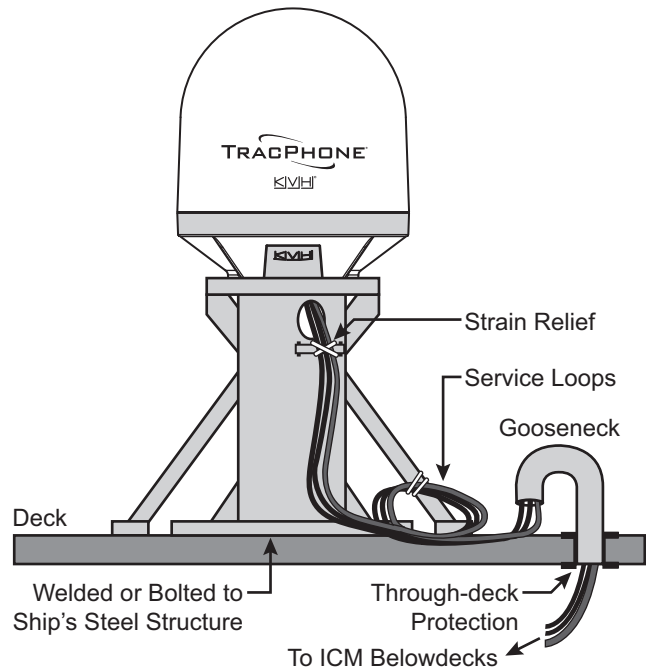

Figure 26: Strain-relief/Service Loops Example



# 9 Mount the Antenna

Follow these steps to mount the antenna to the mounting surface.

- a. Position the antenna over the holes drilled in the mounting surface and make sure the forward arrow inside the baseplate points toward the bow and is parallel to the vessel's centerline (see Figure 27).

**IMPORTANT!**

If the foam seals are used, do not reposition the antenna laterally once the antenna's foam seal has made contact with the foam seal on the mounting surface. If you need to reposition the antenna, lift the antenna first to avoid damage to the foam seals.

- b. Carefully lower the antenna onto the mounting surface and ensure the mounting holes (and foam seals, if used) are aligned.
- c. Using a 7/16" socket/ratchet or nut driver, unlock the three hex latches securing each of the antenna's service hatches (see Figure 18 on page 14). Then gently lower the hatches.



**CAUTION**

Be sure to observe the safe handling instructions in the Safety Data Sheet (SDS) provided with the anti-seize lubricant.

- d. Apply a thin layer of the supplied anti-seize lubricant to the threads of the four supplied 1/2"-13 mounting bolts to prevent galling.
- e. At each of the four antenna mounting holes, place a 1/2" flat washer on a 1/2"-13 bolt and insert the bolt into the hole from above (see Figure 28).
- f. Secure each mounting bolt to the mounting surface using a 1/2" flat washer and a 1/2"-13 lock nut from below (see Figure 28).
- g. Tighten the mounting bolts in a cross pattern until the four rubber feet on the baseplate are bottomed against the mounting surface. KVH recommends that you tighten the nuts to between 35 and 40 ft-lbs (47 and 54 N-m) of torque.

Figure 27: Forward Arrow in Antenna

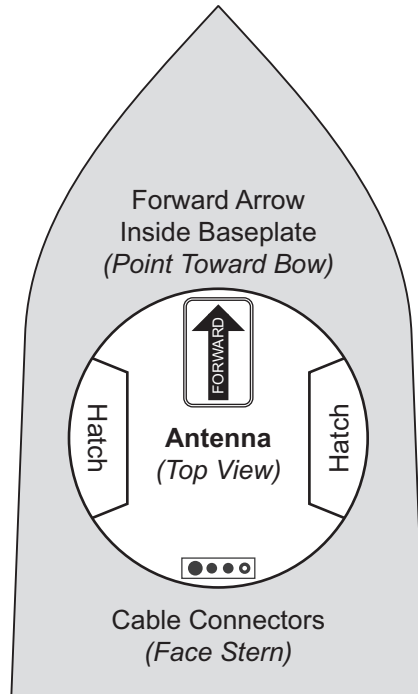
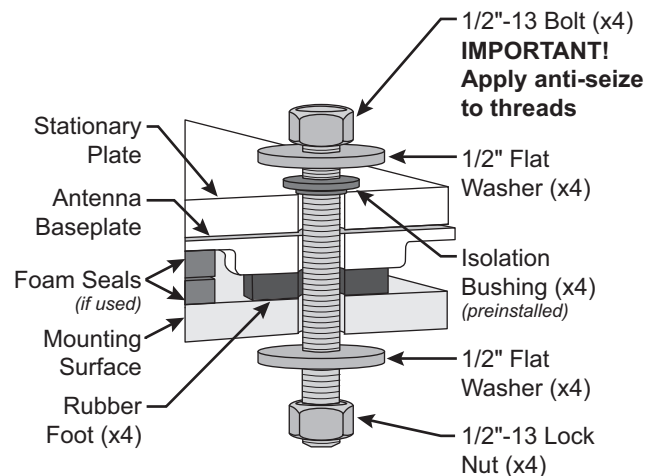

Figure 28: Mounting the Antenna (Side View)



# 9 Continued Mount the Antenna

- h. Disconnect the crane rigging.
- i. Remove the eight screws, flat washers, and lock nuts securing the four lift brackets to the antenna (see Figure 29). Use a 5/32" hex key to keep the screws from turning, and use a 1/2" open-end wrench to loosen and remove the nuts. Remove the lift brackets and hardware and set them aside.

*NOTE: Save the brackets and bracket hardware in case the antenna needs to be moved in the future.*

- j. Install eight 1/4"-20 screws and washers (supplied in the kitpack) in place of the longer mounting bracket screws you removed in the previous step (see Figure 30).
- k. Make sure the power switch inside the antenna is set to the On position (see Figure 31).
- l. Close both antenna service hatches. Secure each service hatch using the three hex latches.

Figure 29: Removing the Lift Brackets

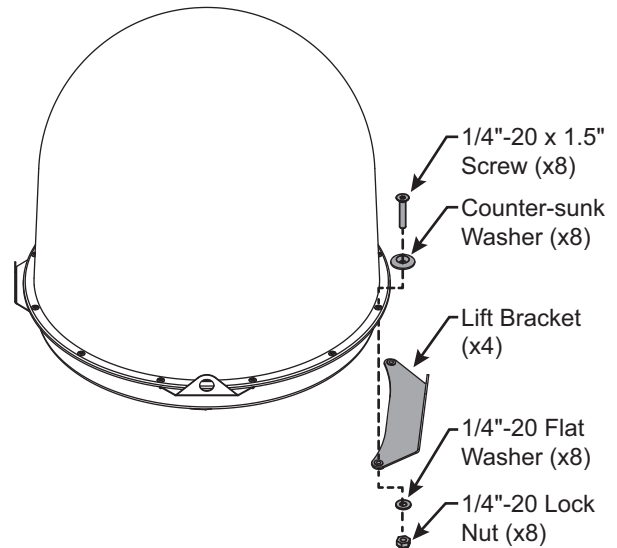

Figure 30: Reinstalling the Radome Hardware

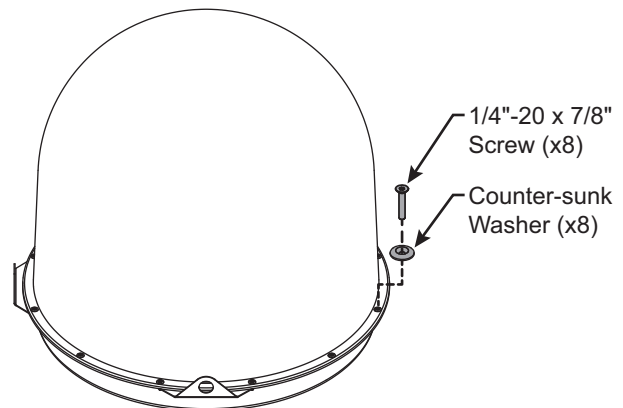
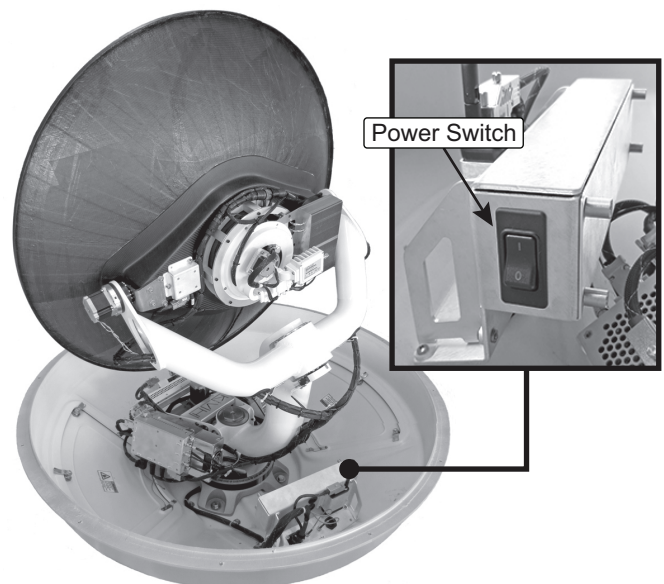

Figure 31: Power Switch Inside Antenna



# 10 Prepare the Data Cable

Follow these steps to attach the supplied grounding sleeve to the antenna's data cable.

- a. At the ICM location, cut the end of the antenna's data cable to the desired length, being sure to maintain an 8" (20 cm) service loop in the cable for easy serviceability.
- b. Using a ruler, measure 7.5" (19 cm) back from the end of the cable. Then, using a utility knife to carefully cut in a rocking motion, sever only the cable's plastic jacket (outermost layer) (see Figure 32). Then twist off the severed length of the plastic jacket.
- c. Measure 6" (15 cm) back from the end of the cable. At that point, carefully pinch the cable braid to create a bulge. Then, using needle-nose cutting pliers, cut the braid along the center of this bulge (see Figure 33).
- d. Cut the cable's drain wire, foil insulation, and fiber to the same length so that their ends are flush with the end of the cable braid (see Figure 34).

Figure 32: Removing the Cable Jacket



Figure 33: Cutting the Cable Braid Bulge

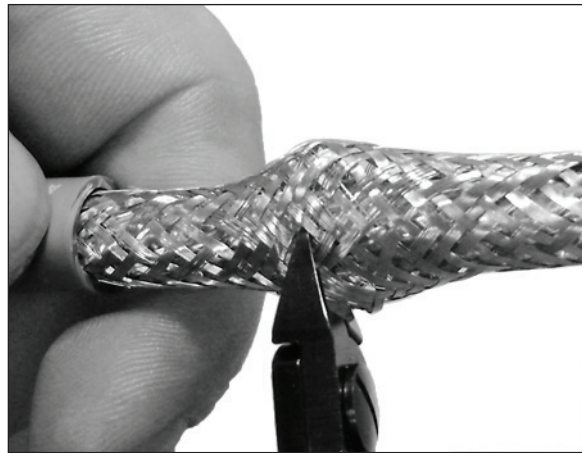
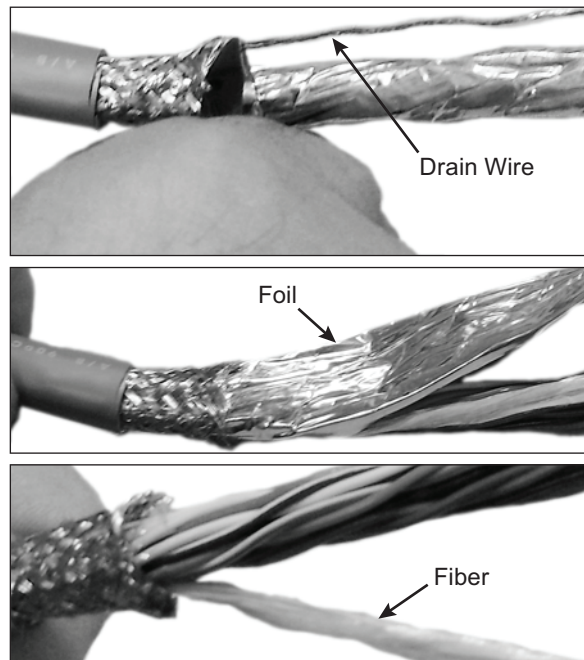

Figure 34: Cutting the Drain Wire, Foil, and Fiber



# 10 Continued Prepare the Data Cable

- e. Thread the data cable through the supplied grounding sleeve. Position the grounding sleeve by aligning the end of its attached ground wire with the ends of the other wires in the data cable (see Figure 35).
- f. Using a heat shrink gun, begin evenly heating the grounding sleeve at the end farthest from the end of the cable to create a seal with the cable's plastic jacket (see Figure 36).
- g. Slowly begin applying heat evenly to the grounding sleeve moving toward the far end of the grounding sleeve until you reach the grounding sleeve's solder ring. Continue applying heat evenly to the ring until the ring's solder begins to wick into the cable braid. Then continue applying heat while working toward the grounding sleeve's remaining length (see Figure 37).
- h. Thread the data cable through the heat shrink tubing (supplied in the kitpack). Align the tubing so that the grounding sleeve protrudes slightly and is barely visible (see Figure 37).
- i. Begin heating the tubing to create a seal by applying heat and working from one end of the tubing, in the same direction you heated the grounding sleeve.
- j. Strip a 1/4" (6 mm) length from the end of the grounding sleeve's ground wire. Then insert the wire into the supplied ring terminal and crimp it into place (see Figure 38).
- k. Dress all of the data cable's wires. Strip back the insulation of each wire approximately 1/4" (6 mm) and gently twist each wire to ensure a good electrical connection.

Figure 35: Aligning the Grounding Sleeve

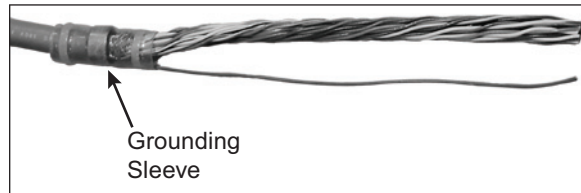

Figure 36: Attaching the Grounding Sleeve

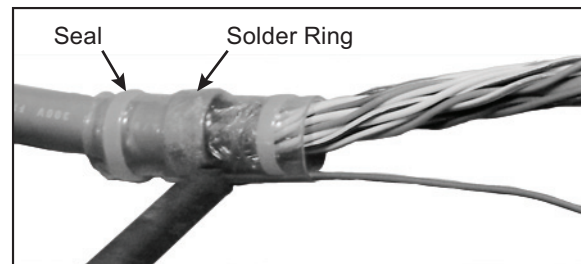

Figure 37: Heat Shrink Tubing

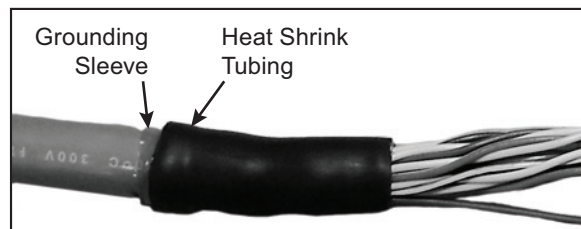

Figure 38: Ring Terminal



# 11 Wire the ICM

Follow these steps to wire the belowdecks equipment (see page 58 for a complete wiring diagram).

## Connect the ICM Jumper Cable

Connect the supplied straight-through Ethernet jumper cable from the “B1” jack to the “B2” jack on the rear panel of the ICM (see Figure 39).

## Attach the Wi-Fi Antennas

Connect the two supplied Wi-Fi antennas to the rear panel of the ICM (see Figure 39).

## Connect the Antenna Data Cable

- Connect the antenna data cable to the supplied 16-position terminal strip connector as shown in Figure 40.

### IMPORTANT!

The diagram refers to wires by **body color/ stripe color**. For example, “Brown/White” means the brown wire with white stripe.

- Place the terminal strip connector into the base of the supplied cable shroud as shown in Figure 41.
- Secure the end of the data cable to the base of the shroud using the supplied clamp. This clamp will help relieve stress on the cable. Secure the clamp in place with the two screws.
- Carefully fit all of the data cable’s wires within the base of the shroud.
- Snap the shroud’s cover onto the base. Be sure not to pinch any wires between the cover and the base.
- Plug the terminal strip connector into the rear panel of the ICM.
- Connect the data cable’s ground wire (attached to the grounding sleeve) to the ground screw on the rear panel of the ICM (see Figure 40).

Figure 39: Jumper Cable and Wi-Fi Antenna Connection

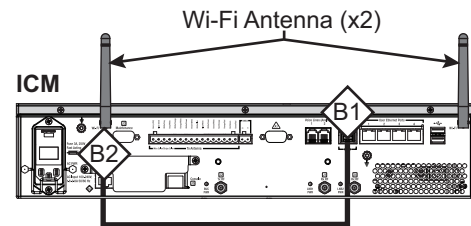

Figure 40: Antenna Data Cable Wiring

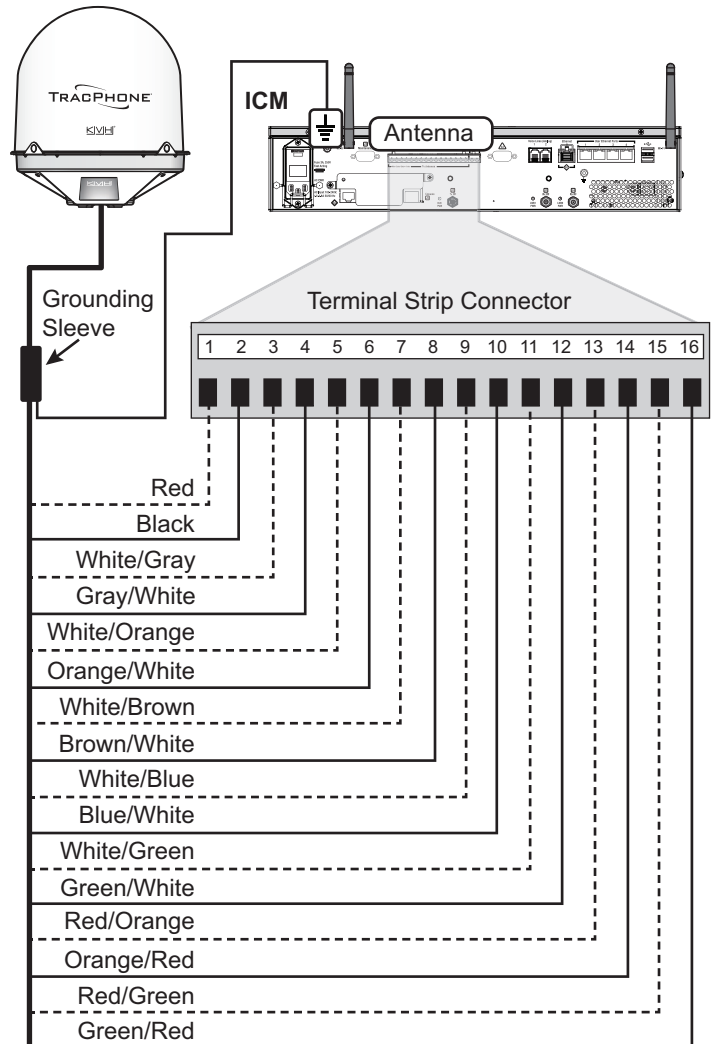
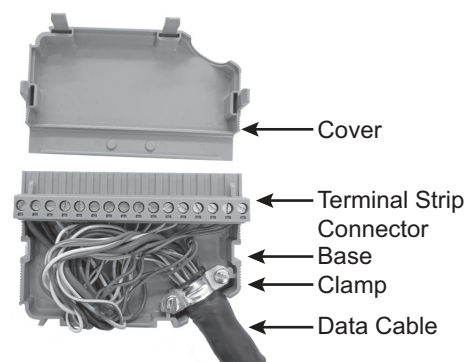

Figure 41: Data Cable Shroud



# 11 Continued Wire the ICM

## Connect an NMEA 0183 Talker

The antenna **requires** a vessel heading input from a customer-supplied NMEA talker. Optionally, you can also provide a vessel position input to serve as a backup to the antenna's internal GPS.

To supply both the required heading and the optional position to the ICM, you can either connect an NMEA 0183 talker that transmits both messages, or connect two devices using an NMEA data multiplexer, such as Actisense® model NDC-4.

- a. Configure the customer's NMEA 0183 talker(s) to transmit a compatible message or messages at 4800 baud (see Figure 42). Refer to "Verifying the NMEA 0183 Message" on page 57 to confirm that the message is transmitting successfully.

**NOTE:** The system does not accept messages that conform to either the NMEA 2000 or NMEA 0183 HS standards.

- b. Make sure the data message(s) includes the checksum, identifiable by a \*xx field at the end of the data sentence (e.g., \$HEHDT,123.4,T\*1F).
- c. Connect the NMEA 0183 talker or NMEA data multiplexer to the supplied 2-position terminal strip connector as shown in Figure 43.
- d. Plug the terminal strip connector into the rear panel of the ICM.

Figure 42: Compatible NMEA 0183 Inputs

Data Type	Compatible Messages
True or Magnetic Heading	\$--HDG \$--HDM \$--HDT \$--OSD \$--THS \$--VHW
Position	\$--RMC

Figure 43: NMEA Wiring

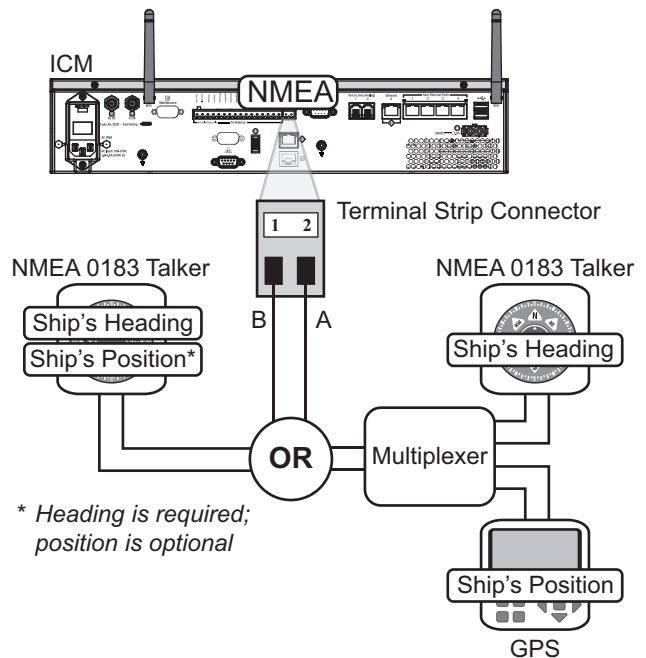

# 11 Continued Wire the ICM

## Connect the RF Cables

### IMPORTANT!

If you are using LMR-600-75 RF cables, do not connect them directly to the ICM. Connect the supplied 1 ft (30 cm) pigtail cables between the RF cables and the ICM.

- Connect the RF coax cable labeled "RX" to the "J1 Rx RF" jack on the back of the ICM (see Figure 44). Hand-tighten, then tighten with a 7/16" torque wrench set to 20 in.-lbs.
- Connect the RF coax cable labeled "TX" to the "J2 Tx RF" jack on the back of the ICM. Hand-tighten, then tighten with a 7/16" torque wrench set to 20 in.-lbs.

### IMPORTANT!

Be sure the RF cables are terminated properly with type "F" connectors.

- Remove the tag from the "J4 Rx RF" jack on the back of the ICM (see Figure 45). Then connect the supplied RF terminator to the "J4 Rx RF" jack according to the tag's instructions. Hand-tighten, then tighten with a 7/16" torque wrench set to no more than 20 in.-lbs.

### IMPORTANT!

The RF terminator (KVH part no. 19-0972) must be installed on the "J4 Rx RF" jack. Improper cable installations are not covered under KVH warranty.

Figure 44: Antenna RF Transmit and Receive Wiring

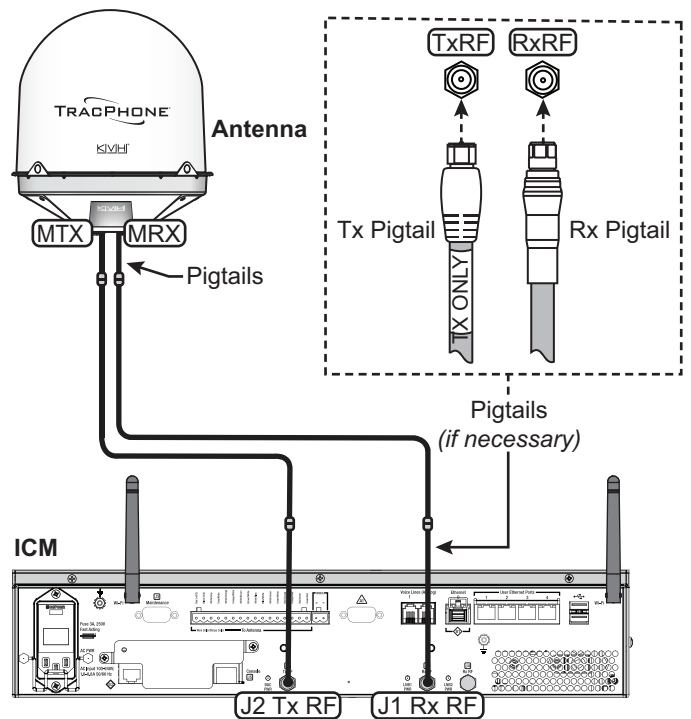
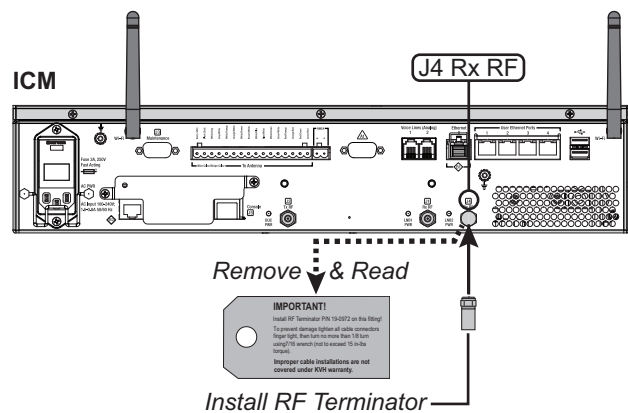

Figure 45: RF Terminator and Instructions Tag



# 12 Connect Power

Before you begin, be sure that you understand the following important requirements:

## AC Power Requirements

The TracPhone system is designed to run on 3-wire single-phase AC power (hot, neutral, and ground). Voltage between hot-neutral and hot-ground should each measure between 100-240 VAC.

Many large ships use two-phase, split-phase, or delta power instead (3 wires: hot, hot, and ground; no neutral). In this case, voltage between hot-hot measures the proper voltage (100-240 VAC); while hot-ground measures only half the voltage (50-120 VAC). Although the TracPhone system can operate on this type of power, the excess voltage present on the second phase will cause a small amount of current to leak onto ship's ground. This leakage current might be unacceptable on some vessels. So check with the customer or ship's electrician and get permission before you run the system on two-phase power. Also be sure to ground the system, as explained below.

If two-phase power is the only available power source onboard, and if leakage current is unacceptable, KVH recommends that you install a suitable isolation transformer to supply single-phase power to the antenna system and run a ground wire from the transformer to ship's ground. In addition, since ground fault protection devices cannot detect faults behind a transformer, you will also need to install a ground fault monitoring device between the isolation transformer and the antenna system if ground fault protection is required on the vessel.

## Grounding Requirements

Proper grounding of the TracPhone system to ship's ground is critically important, as it protects the equipment from electrostatic discharges (ESD). Failure to ground the chassis of the ICM risks damage to the antenna and electric shock.

Figure 46: AC Power Options

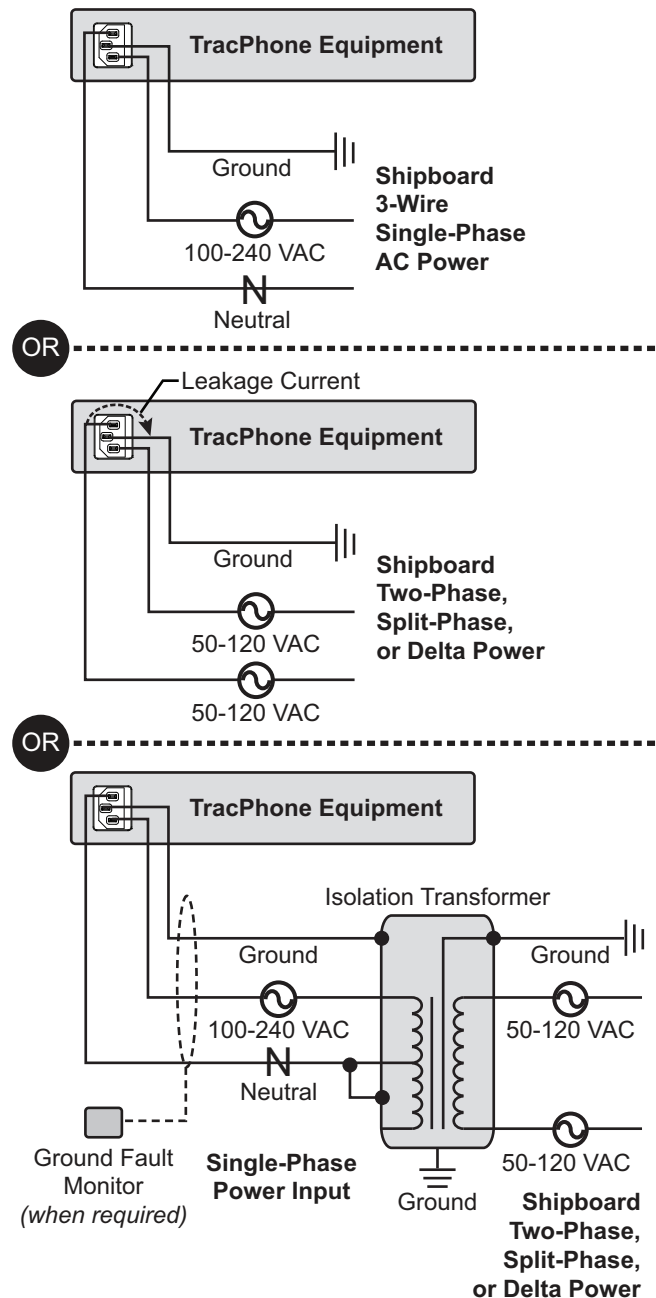

# 12 Continued Connect Power

Follow these steps to connect power.

- a. Before you begin, disconnect vessel power and be sure the vessel is properly grounded in accordance with marine standards.
- b. Connect the supplied ground wire from the ground point on the ICM rear panel to ship's ground (see Figure 47).
- c. Connect the supplied AC power cord to the ICM.

 <b>WARNING</b>	
<p><b>Failure to ground the TracPhone system properly to ship's ground will cause an unsafe floating ground condition, risking damage to the antenna and electric shock, potentially resulting in DEATH.</b> In a floating ground condition, the difference between the equipment's chassis ground and the ship's ground can measure well over 100 volts, when it normally should not exceed 2 volts. Therefore, always measure the difference in potential between chassis ground and ship's ground to make certain that there is no dangerous floating ground condition, even if the ground pin of the vessel's AC power plug appears to be intact.</p>	

- d. Using tie-wraps, secure all wires to the strain-relief bracket at the back of the ICM (see Figure 48). Leave enough slack for easy serviceability.
- e. Plug the ICM power cord into the vessel's 100-240 VAC supply.
- f. Connect the antenna's power cable to the vessel's 100-240 VAC supply via a marine-grade circuit breaker (or equivalent) that complies with applicable electrical codes and safety standards. If the breaker is not within sight of the antenna, it must be able to be locked open. **Be sure to connect the cable's ground wire to the ship's common ground.**

*NOTE: Consider installing an uninterruptible power supply (UPS) to avoid service interruptions during power outages and transitions to/from shore power.*

Figure 47: Power Wiring

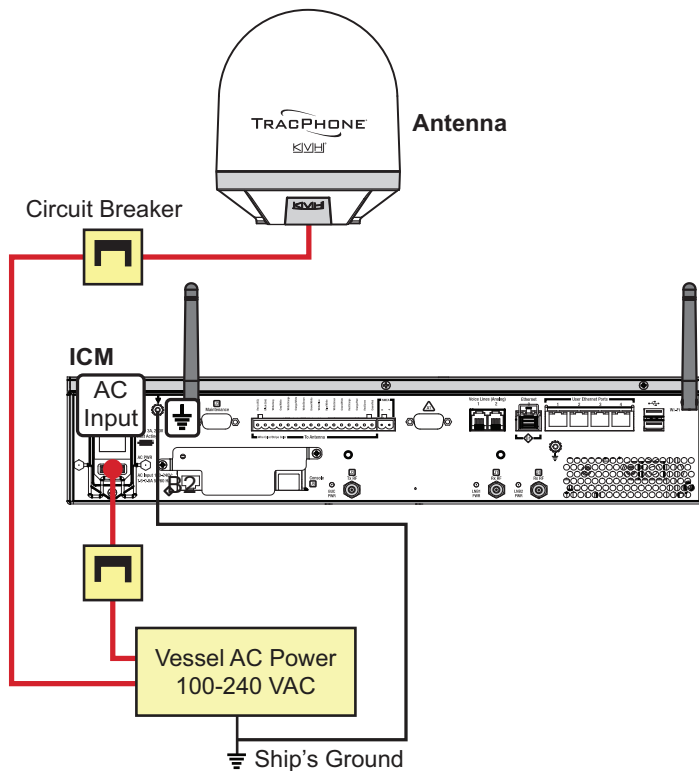
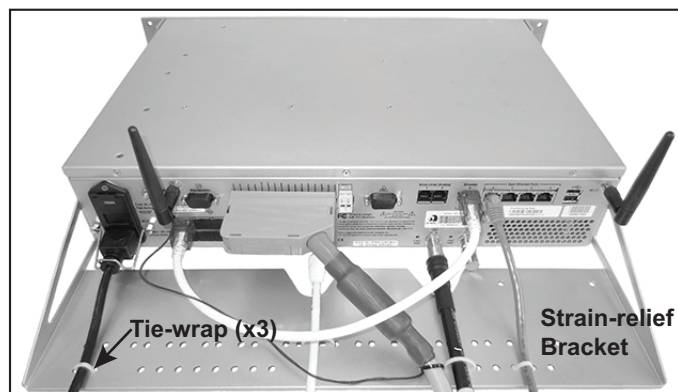

Figure 48: Strain-Relief Bracket



# 13 Turn On the System

Follow these steps to turn on the system.

- a. Ensure the antenna has a clear, unobstructed view of the sky.
- b. Apply vessel power to the TracPhone system.
- c. Press the power button on the front of the ICM (see Figure 49). The button's light should illuminate blue.
- d. Measure the AC and DC voltages between the ground point on the ICM's rear panel (chassis ground) and ship's ground. Make sure you measure less than 2 VAC/2 VDC.
- e. Wait at least 5 minutes for system startup.
- f. After the startup sequence is complete, verify that the ICM's Control Unit status light is lit solid green and the Antenna and Modem lights are lit solid or flashing green (see Figure 50).
- g. Connect your PC to the "User Ethernet 1" port on the rear panel of the ICM (see Figure 51).
- h. Turn off the Wi-Fi on your PC and keep it turned off while connected to the ICM.
- i. Open a web browser on your PC and enter the following address: **http://minivsat.kvh.**

Verify that the TracPhone V11-HTS web interface appears in your browser. If the web interface is not displayed, enter the ICM's IP address (*you can find this address on the LCD: go to Settings > Network Settings > IP Assignments*) and make sure your PC is configured for DHCP (see page 52).

Figure 49: Power Button

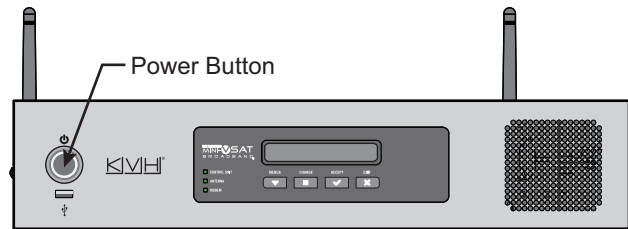

Figure 50: Status Lights

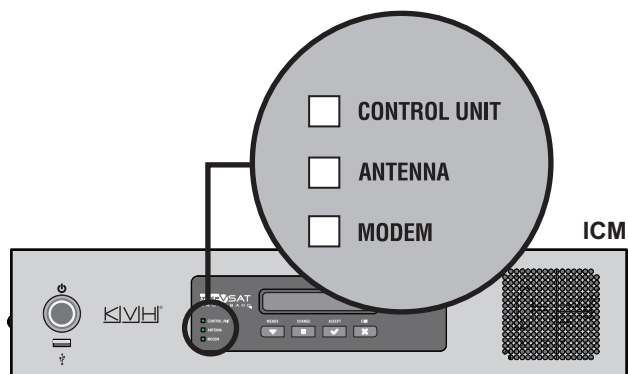
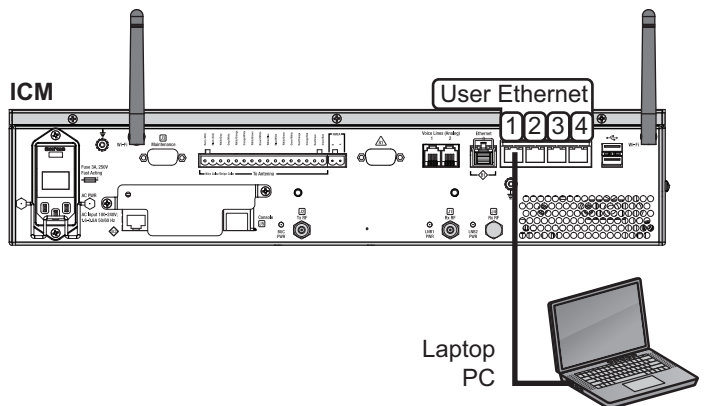

Figure 51: Connecting Your Laptop to the ICM



# 14

# Update the System Software

## If Necessary

Follow these steps to ensure the latest software is installed in the TracPhone system.

### Check the Current Software Version

- a. Go to the TracPhone V11-HTS web interface and click the **Updates** tab. Note the displayed ICM/Antenna software version (see Figure 52).
- b. If the reported software version is earlier than the latest version you downloaded from the KVH Partner Portal, update the system following the steps below.

### Update the Software, If Necessary

*NOTE: This procedure explains how to update the software using the TracPhone V11-HTS web interface. However, you can also update the software using the mini-VSAT iPhone®/iPod Touch® app, a USB drive, or, if the system is activated, via the antenna's Internet connection (airtime charges may apply). Details are available in the Help.*

- a. Click **Choose File**.
- b. At the Login window, enter the default password: “**password**”.
- c. Click **Browse** and navigate to the file you saved on your laptop (see Figure 53).
- d. Click **Check File**.
- e. At the confirmation message, click **Update**.
- f. Wait for the software update to complete. It might take up to 40 minutes.

Figure 52: Updates Page on Web Interface



Figure 53: Update File Selected for Upload

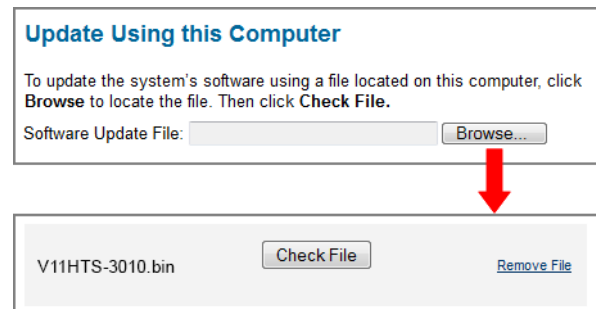

# 15 Customize the Web Interface

Follow these steps to customize the web interface for the customer's use.

## Set the Administrator Password

The user must be logged in as an administrator to make changes to the system's configuration. Follow these steps to change the administrator password to something unique.

- At the TracPhone V11-HTS web interface, click the **Settings** tab. Then click **Account**.
- In Security, click **Edit**.
- For the current password, enter the default password: "password" (see Figure 54).
- Enter and then re-enter the new password. Then click **Save Settings**.

## Enter the Vessel Name

The vessel name is displayed on the home page and in all support communications. Follow these steps to enter the correct vessel name.

- At the TracPhone V11-HTS web interface, click the **Settings** tab. Then click **Account**.
- In Vessel Name, click **Edit**.
- Enter the vessel name (see Figure 55). Then click **Save Settings**.

## Assign Phone Line Name(s)

The phone line names are displayed on the home page and in all support communications. Follow these steps to assign a name (i.e., location) to each active phone line (second line is optional).

- At the TracPhone V11-HTS web interface, click the **Settings** tab. Then click **Other**.
- In Phone Line Names, click **Edit**.
- Enter names for Lines 1 and 2, as needed (see Figure 56). Then click **Save**.

Figure 54: Setting the Administrator Password

The screenshot shows a web interface titled "Security". Below the title is the instruction "Change the administrator's login password." There are three input fields: "Enter the current password:" with a masked field of seven dots; "Enter the new password:" with a masked field of ten dots and a "Strong" indicator (a checkmark in a box) to its right. Below the new password field is a note: "(between 4 and 20 characters long, with at least one letter and one number, case sensitive)". The third field is "Re-enter the new password:" with a masked field of ten dots. At the bottom right are two buttons: "Cancel" and "Save Settings".

Figure 55: Entering the Vessel Name

The screenshot shows a web interface titled "Vessel Name". Below the title is the instruction "Change the name displayed on the Home page and in support communications." There is one input field labeled "Vessel Name:" containing the text "Britanic". At the bottom right are two buttons: "Cancel" and "Save Settings".

Figure 56: Assigning Phone Line Names

The screenshot shows a web interface titled "Phone Line Names". Below the title is the instruction "The names displayed on the home page and in support communications (see example)". There are two input fields: "Line 1:" containing "Bridge" with a note "(up to 25 characters)" to its right; and "Line 2:" containing "Crew Quarters" with a note "(up to 25 characters)" to its right. At the bottom right are two buttons: "Cancel" and "Save".

# 16 Set Up No-Transmit Zones

To prevent exposure to RF energy (see the hazard area illustration on page 1), you can configure up to two no-transmit zones for areas where crew and/or passengers frequent (see Figure 57). The system will disable the transmitter whenever the antenna is pointing within one of these zones.

Follow these steps to set up a no-transmit zone.

- Determine the necessary azimuth range for the no-transmit zone(s). You will need to enter, in clockwise order, beginning and ending azimuths that define the outer boundaries of the zone(s) **relative to the antenna's forward arrow**, which should be pointing toward the bow (see Figure 58).
- Determine the necessary elevation range for each no-transmit zone(s) (see Figure 59).

**NOTE:** Each no-transmit zone must span at least  $5^\circ$  in both azimuth and elevation.

Figure 57: Example of No-Transmit Zone Azimuth Range

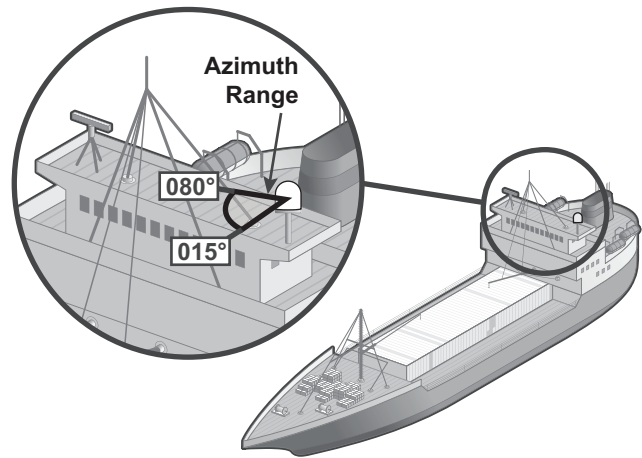

Figure 58: Azimuths Relative to Antenna's Forward Arrow

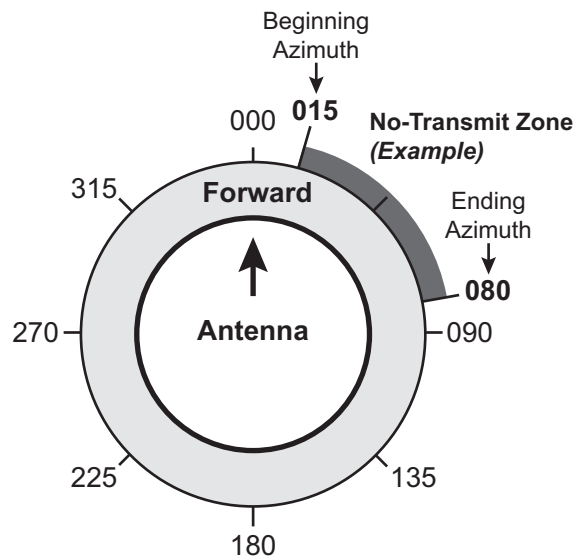
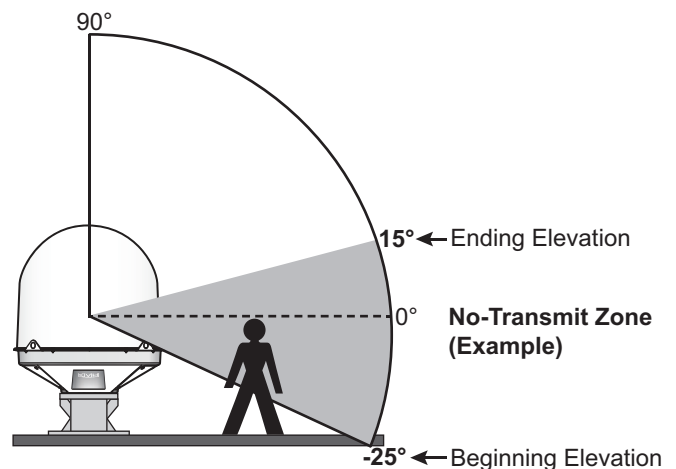

Figure 59: Example of No-Transmit Zone Elevation Range



# 16 Continued Set Up No-Transmit Zones

- c. At the TracPhone V11-HTS web interface, click the **Settings** tab. Then click **No-Transmit Zones**.
- d. Click **Edit**.
- e. Make sure **Enforce Zones** is selected (see Figure 60).
- f. Enter the azimuth and elevation ranges for Zone 1.
- g. If you need to set up a second zone, select Zone 2 from the drop-down menu then enter the azimuth and elevation ranges for Zone 2.
- h. Click **Save Settings**.
- i. At the confirmation message, click **Save**.

Figure 60: No-Transmit Zones Page of Web Interface

**No-Transmit Zone Ranges:**

**Enforce Zones**  
*The antenna will not transmit within the zone(s) specified below.*

**Ignore Zones**  
*The antenna will be able to transmit in any direction without restriction. Be sure everyone stays the minimum safe distance away from the antenna.*

**Choose a No-Transmit Zone:**

Zone 1

**Zone 1**

**Azimuth Range:**  
*Must span at least 5°*

From:  °

To:  °

**Elevation Range:**  
*Must span at least 5°*

From:  °

To:  °

Cancel Clear Zones Save Settings

# 17 Commission the Modem

Follow these steps to commission the ICM's built-in modem, if required.

**IMPORTANT!**

If the modem was commissioned at the factory (look for a notice attached to the ICM), you can skip this step as long as you are using RG-11 RF cables 80-100 ft (25-30 m) in length. If a notice is not attached to the ICM, or you used a different RF cable type or length, or you installed a different antenna from the unit that shipped with the ICM, you must complete this step.

This process is required to determine the 1 dB compression point of the BUC (block up-converter) (see Figure 61) and the maximum transmit power. The process takes about 30 minutes to complete.

- a. Ensure the antenna has a clear, unobstructed view of the sky.
- b. At the TracPhone V11-HTS web interface, verify that the antenna is tracking the service satellite and the system is online (see Figure 62).
- c. Click the **Support** tab and gather all the information listed on the Modem Commissioning Worksheet (supplied in the Welcome Kit).
- d. Call KVH Technical Support. KVH will coordinate with the Network Operations Center (NOC) to complete the remaining commissioning steps over the air. You will just need to provide the information you noted on the worksheet.

*NOTE: If the NOC is unable to access the system remotely over the satellite connection, you will need to assist with the commissioning process by adjusting settings at the modem's local web interface as directed by the NOC. Refer to "Full Modem Commissioning Steps" on page 42 for details.*

Figure 61: BUC's 1 dB Compression Point Determination

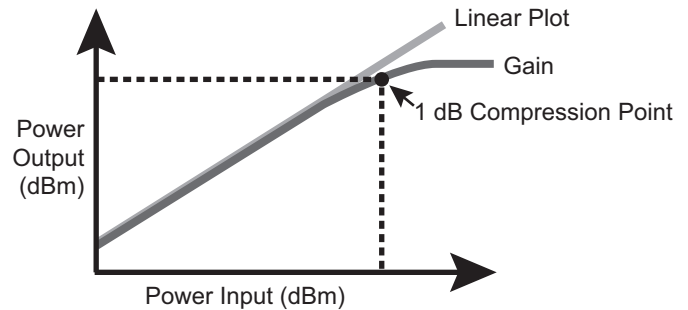

Figure 62: Good Service Connection Indicated on Home Page

My VSAT Status	
Connection Status	Antenna State
<b>ONLINE</b> SNR: 5.80dB	<b>TRACKING</b>

Figure 63: Modem Commissioning Worksheet Information

No.	Item	Value
①	Antenna State "TRACKING" required	
②	Orbital Slot	
③	Satellite Name (see table below)	
④	Beam ID	
⑤	Frequency	
⑥	Management IP	
⑦	Vessel Position	Lat:
		Long:
⑧	Modem State "IN_NETWORK" required	
⑨	FL Carrier Symbol Rate (2nd field)	
⑩	Modem S/N	

# 18 Test the System

Once the modem is commissioned, follow these steps to test the system for proper operation.

**NOTE:** Only test the system *after* you have completed modem commissioning.

- a. Ensure the antenna has a clear, unobstructed view of the sky.
- b. Verify that the antenna is tracking the service satellite and the system is online, as indicated by the Home page of the TracPhone V11-HTS web interface (see Figure 64).
- c. On the Home page, make sure the vessel's heading is displayed in the Real-time Vessel & VSAT Satellite Display (see Figure 65). If it is not shown, check your wiring to the NMEA 0183 talker.
- d. Enter the following address in your web browser: <http://test.minivsat.net>.  
  
Verify that the Welcome page appears, indicating good communication between the TracPhone system and the land-based hub (see Figure 66).
- e. Turn on all other electronic equipment above deck within the proximity of the antenna. Verify that the system continues to operate without any degradation in performance.
- f. Fill out the Installation Checklist (provided in the Customer Welcome Kit) and return it to KVH. Refer to the instructions on the form.

**IMPORTANT!**

Submission of the Installation Checklist is **required** to certify the quality of your installation.

Figure 64: Good Service Connection Indicated on Home Page

My VSAT Status	
Connection Status	Antenna State
 <b>ONLINE</b> SNR: 5.80dB	<b>TRACKING</b>

Figure 65: Heading Displayed on Home Page

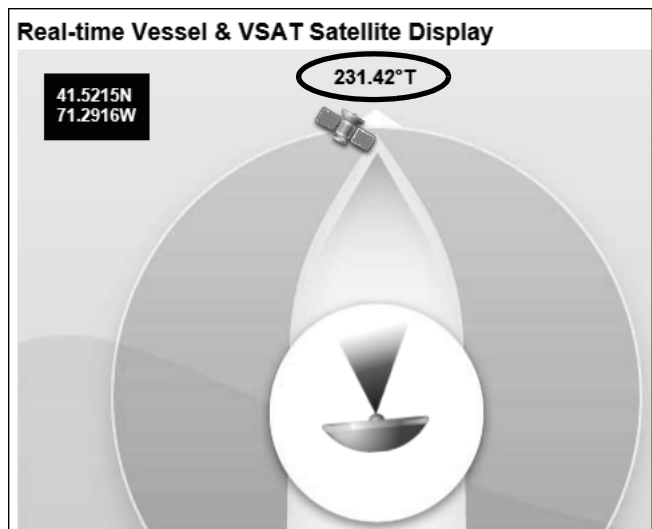

Figure 66: Welcome Page for Testing

**MINI-VSAT BROADBAND** KVH

## Welcome!

You have successfully reached the mini-VSAT Broadband<sup>SM</sup> Service.

Please educate your customer on performing the following steps to activate their new TracPhone system for mini-VSAT Broadband Service.

**Step 1** Complete Activation Orders

- mini-VSAT Broadband Airtime Services Activation Order & End User Agreement
- Additional Authorized Representatives Form (if applicable)

These forms are provided in the Customer Welcome Kit. They are also available in PDF format at [www.kvh.com/mvbservice](http://www.kvh.com/mvbservice)

# 19 Configure the Network

The ICM includes four Ethernet ports and a built-in wireless access point (WAP) that can be configured in a variety of ways to meet the customer's needs (see Figure 67). Some of the most common ICM network configurations can be selected directly from the TracPhone V11-HTS web interface. Follow these steps to select one of these configurations. If the customer requires a custom configuration, please contact KVH Network Services at [networkservices@kvh.com](mailto:networkservices@kvh.com).

**NOTE:** The customer may also change the ICM's network configuration at the mini-VSAT Manager (go to [www.mykvh.com](http://www.mykvh.com)). To access myKVH, the customer will need to log in with the username and password provided by KVH at the time of activation.

**IMPORTANT!**

The TracPhone system provides two separate data paths for Internet access:

- **High-speed** – Fastest speeds; uses Open airtime plan that includes an allotment of data usage; overage charges apply
- **Unlimited** – Minimal speeds; uses Fixed-rate airtime plan

- At the TracPhone V11-HTS web interface, click the **Settings** tab. Then click **Network Settings**.
- In Network Configuration, click **Edit**.
- Select an option from the **Configuration** drop-down menu. Then click **Save** (see Figure 68 and Figure 69).
- At the confirmation message, click **Save**.
- Follow the additional instructions on the following pages for your chosen configuration.

**Standard HTS:** Go to page 35

**Static IP HTS:** Go to page 36

**Open Access HTS:** Go to page 37

Figure 67: ICM Ethernet Ports and Wireless Access Point

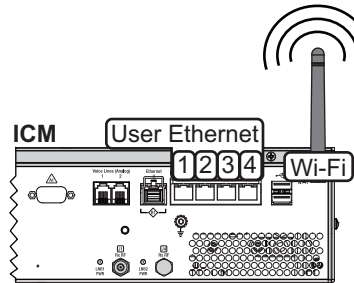

Figure 68: Selecting a Network Configuration

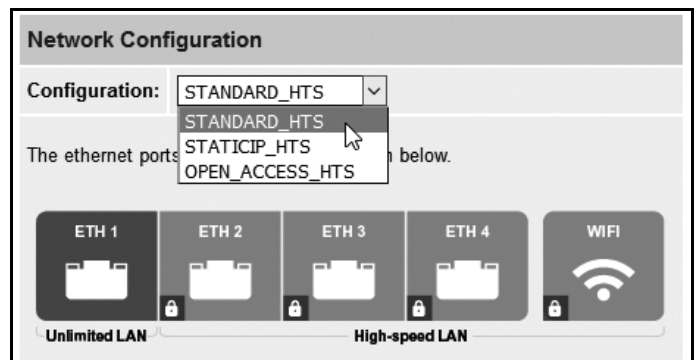

Figure 69: User Selectable Network Configurations

Option	Description
Standard HTS	Port 1: Unlimited LAN Ports 2-4, Wi-Fi: High-speed LAN with access control
Static IP HTS	Port 1: Unlimited LAN Ports 2-3, Wi-Fi: High-speed LAN with access control Port 4: Accessory LAN*
Open Access HTS	Port 1: Unlimited LAN Ports 2-3, Wi-Fi: High-speed LAN with unrestricted access Port 4: Accessory LAN*

\* Accessory LAN reserved for optional service, such as Global Static IP, external MTA, or Crew Calling.

# 19 Continued Configure the Network

## Standard HTS Configuration

In a Standard HTS configuration, Ethernet port 1 provides unlimited Internet access with no user logins or controls. Ports 2 through 4 and the built-in WAP require a user login and provide high-speed Internet access. This is the default configuration. Follow these additional steps to configure the network.

- To enable the ICM's WAP for wireless access, follow the steps in "ICM Wireless Settings" on page 38.
- Connect the customer's computers and/or other network devices to the ICM. Make sure you connect to the port(s) that correspond to the desired Internet connection path(s): Unlimited or High-speed (see Figure 71). You might wish to add an external WAP (or Wi-Fi router configured for bridge mode) to supplement Wi-Fi access.
- Make sure all computers are configured for DHCP addressing (see page 52). Devices connected to the ICM (via Ethernet cables or Wi-Fi) will receive IP addresses from the ICM via DHCP. The ICM serves as a router.
- Inform the customer that they need to set up user names and passwords and allocate data for each High-speed LAN user at the mini-VSAT Manager ([www.mykvh.com](http://www.mykvh.com)).

**NOTE:** By default, the High-speed LAN has a gateway of 192.168.6.1 and assigns IP addresses in the 192.168.6.50-150 range. If this configuration conflicts with an existing onboard network, you may change the settings at the TracPhone V11-HTS web interface (go to Settings > Network Settings). The Unlimited LAN (gateway 192.168.5.1) cannot be changed at the web interface. If it conflicts with an existing network, please contact KVH Technical Support for assistance.

Figure 70: Standard HTS Configuration



Figure 71: Standard HTS Configuration Wiring Example

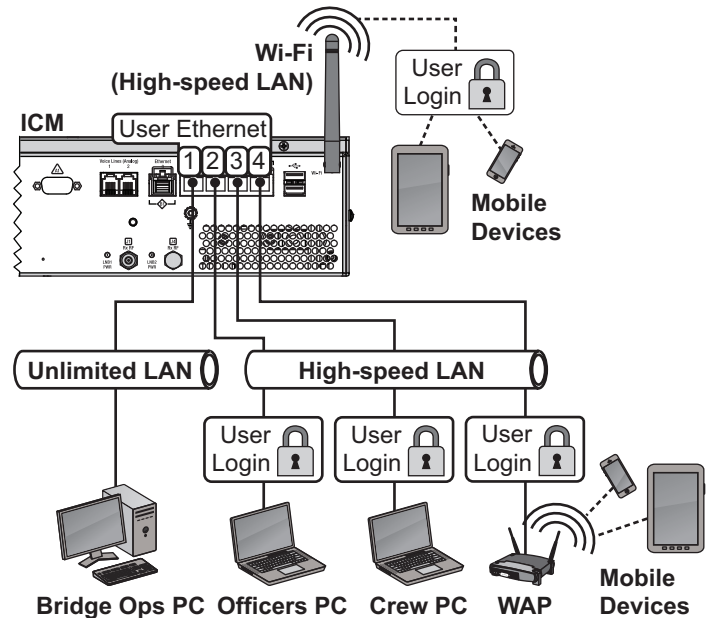

# 19 Continued Configure the Network

## Static IP HTS Configuration

In a Static IP HTS configuration, Ethernet port 1 provides unlimited Internet access with no user logins or controls. Ports 2 and 3 and the built-in WAP require a user login and provide high-speed Internet access. Port 4 is reserved for an optional KVH service, such as Global Static IP.

Global Static IP service allows you to set up a network device with an IP address that can be accessed directly from the Internet. It does not receive an IP address from the ICM. If you require Global Static IP Service, follow these additional steps to configure the network.

### IMPORTANT!

A static IP address should only be assigned to a secure device, such as a firewall router.

- Ask the customer to fill out the request form at [www.kvh.com/staticip](http://www.kvh.com/staticip). In addition, the system must be activated for mini-VSAT Broadband service, and it must remain online until KVH configures the system over the air.
- Connect the static IP device to "User Ethernet" port 4 on the ICM (see Figure 73).
- The customer will need to configure the device's TCP/IP properties according to the instructions KVH will provide in an email upon fulfilling the static IP request.
- Connect all other (non-static IP) computers and/or network devices to "User Ethernet" ports 1-3 and Wi-Fi, as required. Follow the steps in "Standard HTS Configuration" on page 35.

Figure 72: Static IP HTS Configuration

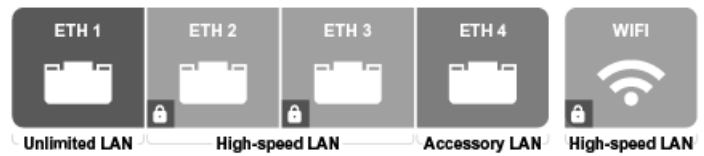
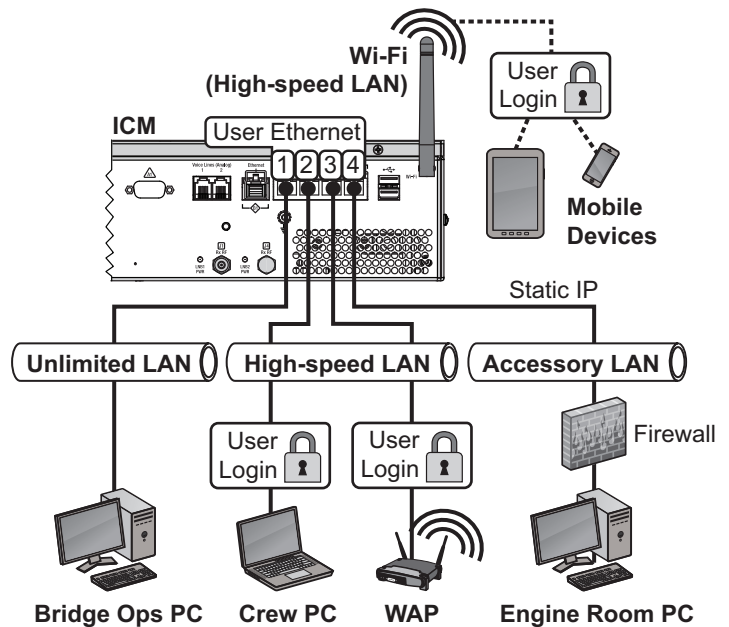

Figure 73: Static IP HTS Configuration Wiring Example



# 19 Continued Configure the Network

## Open Access HTS Configuration

In an Open Access HTS configuration, Ethernet port 1 provides unlimited Internet access, and ports 2 and 3 and the built-in WAP provide high-speed Internet access, with no user logins or controls. Port 4 is reserved for an optional KVH service, such as Global Static IP.

This configuration is identical to the Static IP HTS configuration described on the previous page with one exception: user names/passwords and data allocations are not enforced to control access to the High-speed LAN. Internet access is unrestricted.

Figure 74: Open Access HTS Configuration

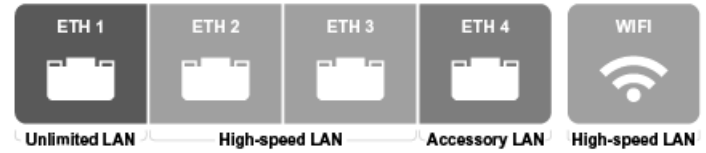
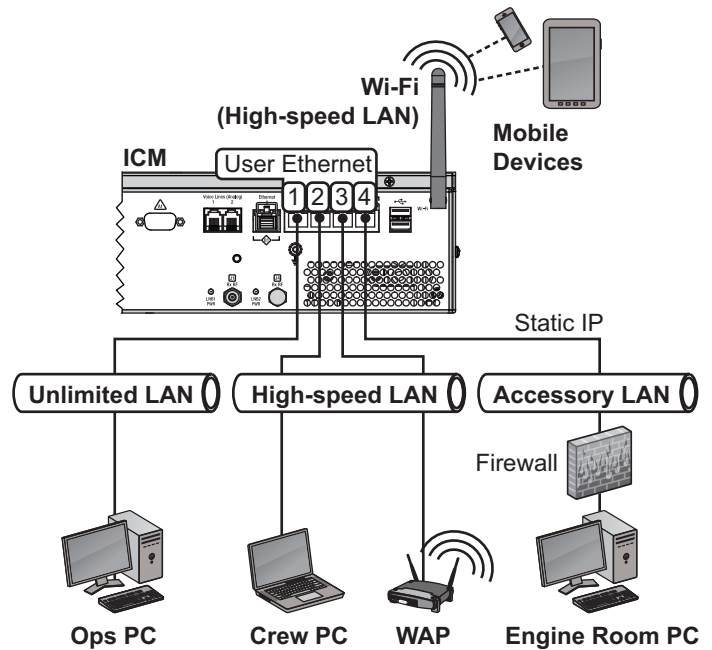

Figure 75: Open Access HTS Configuration Wiring Example



# 19 Continued Configure the Network

## ICM Wireless Settings

With Wi-Fi enabled, vessel devices can connect to the ICM via its built-in wireless access point (WAP) and receive IP addresses from the ICM via DHCP (see Figure 76). Follow these steps to enable and configure the WAP, if desired by the customer.

### IMPORTANT!

Establishing a wireless connection onboard a steel vessel might require a special external WAP and advanced networking expertise.

**NOTE:** The customer may also change the ICM's wireless settings at any time at the mini-VSAT Manager ([www.mykvh.com](http://www.mykvh.com)).

- At the TracPhone V11-HTS web interface, click the **Settings** tab. Then click **Network Settings**.
- In Wi-Fi Settings, click **Edit**.
- Set the following wireless options, then click **Save** (see Figure 77):
  - State:** Select On.
  - SSID:** Enter a unique name for the vessel network.
  - Protocol:** Select either 802.11b or 802.11g.
  - Security:** Select either security type – WPA2 or WEP (128-bit).
  - Password/Passphrase:** If you selected WPA2, enter a password (between 8-20 characters). If you selected WEP, enter a passphrase (must be 13 characters).
  - Channel:** Keep the default, or select any channel for wireless communications.

### IMPORTANT!

Failure to apply security settings will make the vessel's wireless network vulnerable to outside intrusion.

- At the confirmation message, click **Save**.

Figure 76: Wireless DHCP (Example)

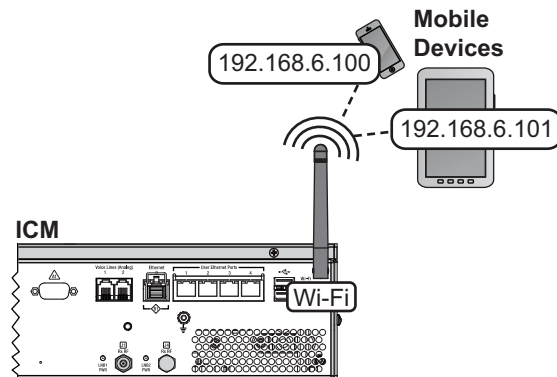

Figure 77: Wi-Fi Settings on the ICM

Wi-Fi Settings	
State:	<input checked="" type="radio"/> On <input type="radio"/> Off (default)
SSID:	<input type="text" value="MyVesselNetwork"/> (Up to 32 characters)
IP Address:	192 . 168 . 6 . 1
Protocol:	802.11b
Security:	WPA2
Password:	<input type="password" value="••••••••"/> (between 8 to 20 characters)
Channel:	7
<input type="button" value="Cancel"/> <input type="button" value="Save"/>	

# 19 Continued Configure the Network

## Optional CommBox Software

CommBox software extends the system's network capabilities (see Figure 78). Two options are available:

- **Standard Bundle:** Provides least cost routing, onboard firewall, web caching, web image compression, ad removal, and URL and content filtering
- **Enterprise Bundle:** Adds automated file transfers, differential synchronization, mail relay server, web mail client, anti-spam and anti-virus filters, roaming crew accounts, and prepaid Internet and email services; integration with a CommBox hub is required

KVH will coordinate directly with the customer to select, install, and configure the appropriate bundle to meet their needs.

Figure 78: Available CommBox Options

Option	KVH Part No.
CommBox Standard Bundle*	35-0010
CommBox Enterprise Bundle*	35-0011

\* *If the customer is interested in a CommBox solution, ask them to contact KVH Network Services at [networkservices@kvh.com](mailto:networkservices@kvh.com) for a consultation.*

# 20 Connect Voice Line Equipment

Follow these steps to connect the vessel's phone(s) and any purchased voice line accessories to the system.

## Connect Vessel Phone(s)

Using the supplied RJ-11 cables, connect the customer's analog (not digital) phone(s), fax machine, and/or PABX to the desired "Voice Line" jack(s) on the ICM (see Figure 79). Each jack is linked to a phone line.

### **IMPORTANT!**

The second phone line is optional – an additional monthly fee applies. If the customer has not purchased a second line, do not connect anything to "Voice Line 2."

Figure 79: Connecting Vessel Phones (Example)

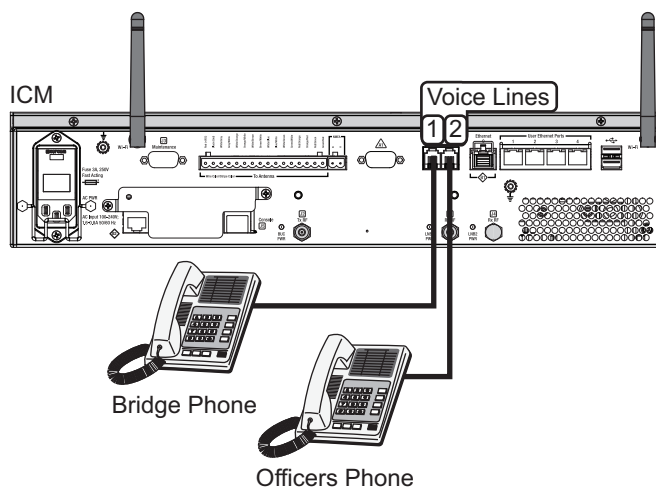

# 21

## Educate the Customer

Give the Welcome Kit to the customer, make sure they know the differences between the Unlimited LAN and the High-speed LAN, give them the administrator and Wi-Fi passwords, and show them how to use the system. Be sure they understand the following:

- **The antenna transmits RF energy that is potentially harmful.** Whenever the system is powered on, make sure everyone stays the minimum safe distance away from the antenna (see illustration on page 1). If no-transmit zones were set up, make sure the customer understands where they are.
- Read the End User Agreement (available at [www.kvh.com/mvbcustomercenter](http://www.kvh.com/mvbcustomercenter)).
- Keep the radome installed on the antenna at all times. The radome protects the antenna's moving parts from wind, rain, and debris.
- The antenna must have a clear view of the sky to communicate via satellite. Common causes of blockage include masts, trees, buildings, and bridges (see Figure 81). Dirt buildup on the radome can also affect communications.
- The vessel must be located within the coverage area of the satellite (see [www.kvh.com/htscoverage](http://www.kvh.com/htscoverage)).
- The system must be activated for mini-VSAT Broadband service (see [www.kvh.com/mvbservice](http://www.kvh.com/mvbservice)).
- Data usage and overage alerts via email and text message, as well as user logins and their associated data allocations, can be configured easily over the Internet at the mini-VSAT Manager (go to [www.mykvh.com](http://www.mykvh.com)).

### For More Information

Refer to the Help provided on the web interface's Support page (see Figure 82). The Condensed version is text only and resides on the ICM. The Extended version includes images and resides on the KVH website (airtime charges may apply).

Figure 80: Customer Welcome Kit



Figure 81: Example of Satellite Blockage

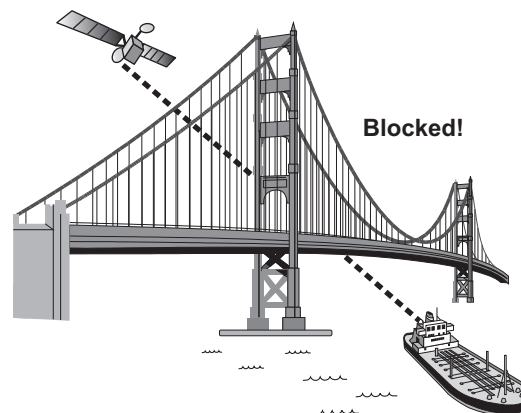
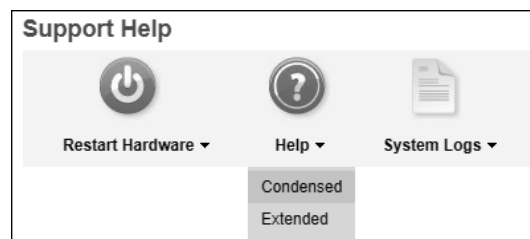

Figure 82: Help Options on Support Page



# A Full Modem Commissioning Steps

## Appendix

If you need to commission the modem (see “Commission the Modem” on page 32), and if the NOC is unable to access the TracPhone system remotely over the satellite connection (a rare case), follow the steps below to access the built-in modem’s web interface and assist the NOC with the commissioning process.

- a. At the TracPhone V11-HTS web interface, click the **Support** tab.
- b. Click the link on the Support page to open the modem commissioning wizard (see Figure 83). Then log into the wizard using the administrator password you set up earlier. The default settings are as follows:
  - User Name: **admin**
  - Password: **password**
- c. At Step 1, click **Enter Commissioning Mode** (see Figure 84).

Figure 83: Support Page Link to Commissioning Wizard and Login

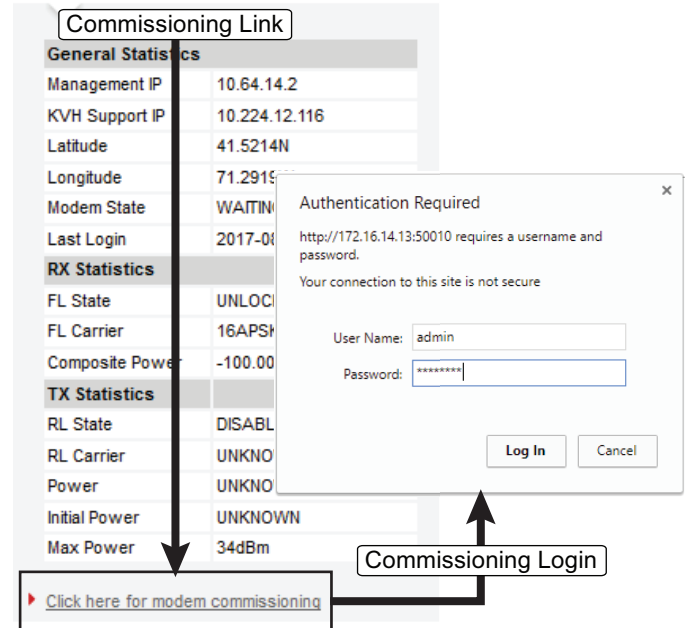
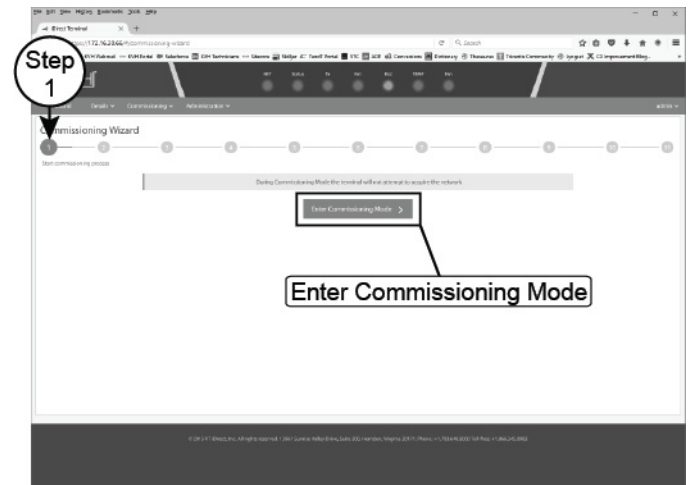

Figure 84: Commissioning Process – Step 1



# A

# Continued Full Commissioning Steps

## Appendix

- d. At Step 2, click **Continue without changes** (see Figure 85).

**IMPORTANT!**  
If you need to abort commissioning at any time, select **Exit commissioning mode**.  
*Cycling power will not revert the ICM to normal operation mode.*

- e. At Step 3, enter your latitude and longitude (see Figure 86).

**NOTE:** Select the direction (North/South, East/West) before entering each value.

- f. Enter the orbital slot (longitude) of the satellite the antenna is tracking.

**NOTE:** Select the direction (East/West) before entering the value.

- g. Click **Save remote location and continue** (see Figure 86).

Figure 85: Commissioning Process – Step 2

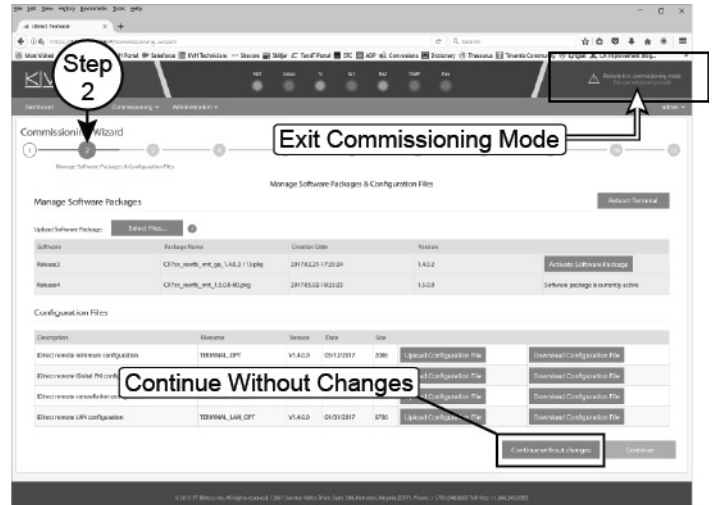
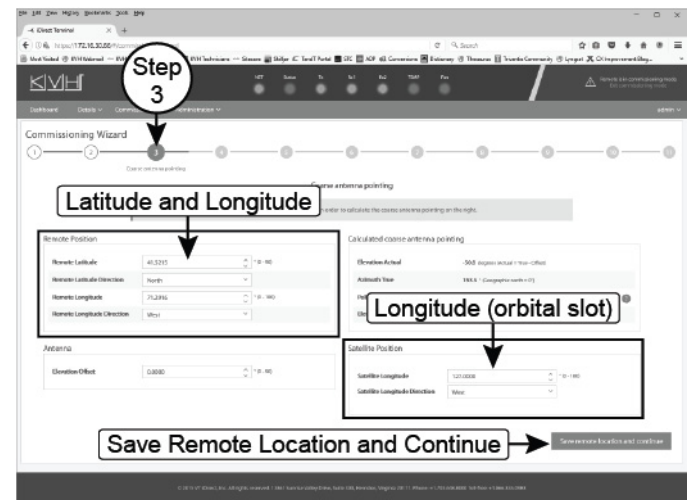

Figure 86: Commissioning Process – Step 3



# A

# Continued Full Commissioning Steps

## Appendix

- h. At Step 4, enter the satellite parameters provided by the NOC (see Figure 87). Verify that the Frequency and the FL Carrier Symbol Rate match the values on the worksheet, and enter zeros for Latitude Variance and Polarization Skew.

When you are done, click **Continue and position antenna** (see Figure 87).

- i. At Step 5, wait until you see the following (see Figure 88):

- Demod Lock Status: Locked
- Antenna Status: Functional, May Transmit

Then click **Stop Antenna pointing**.

Figure 87: Commissioning Process – Step 4

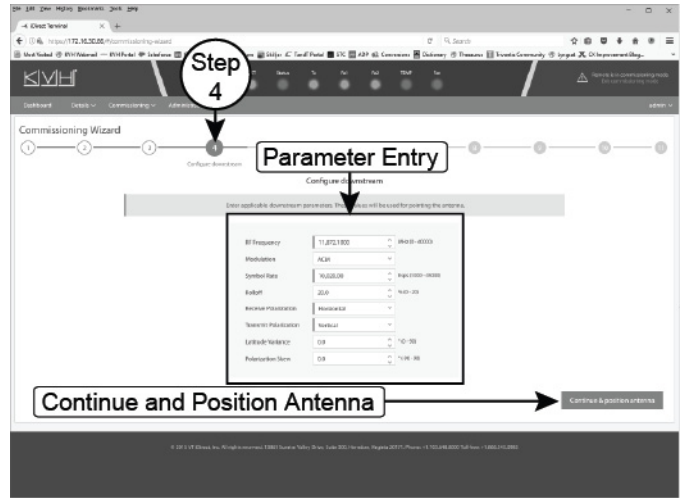
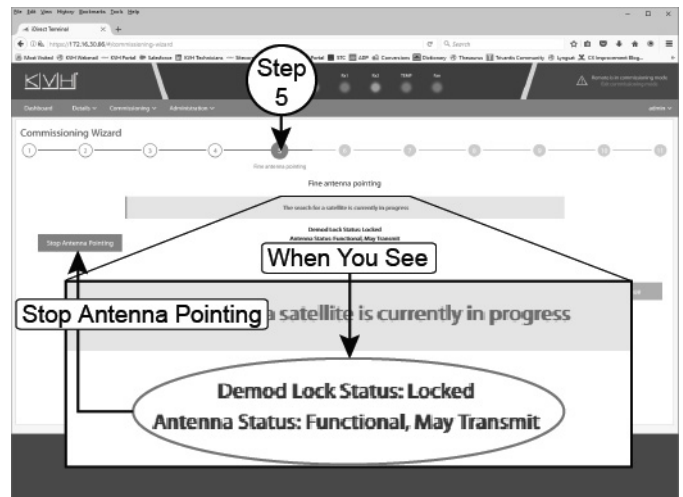

Figure 88: Commissioning Process – Step 5



# A Continued Full Commissioning Steps

## Appendix

- j. When **Start Antenna Pointing** appears, click **Continue** (see Figure 89).
- k. At Step 6, click **Continue** (see Figure 89).
- l. At Step 7, click **Skip** (see Figure 89).

Figure 89: Commissioning – Steps 5 Through 7

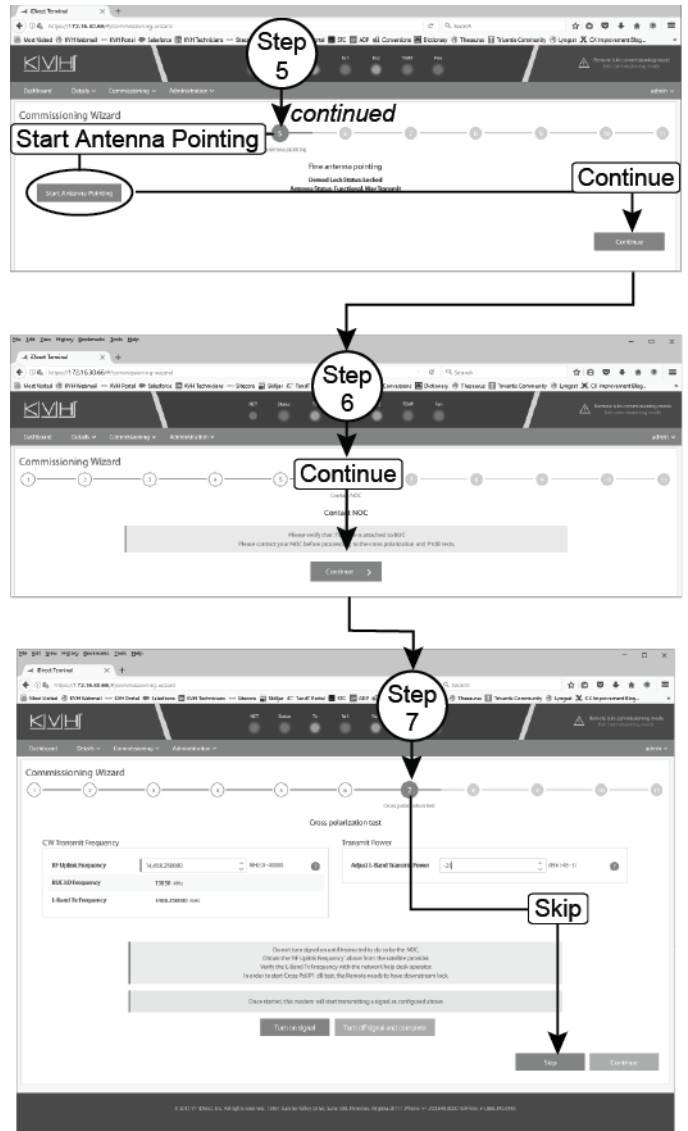

# A

# Continued Full Commissioning Steps

## Appendix

- m. At Step 8, select **CW modulation** and enter the **RF Uplink Frequency** and the initial **Transmit power** that the NOC provided (see Figure 90). Then click **Turn on signal**.
- n. Continue by using **Adjust L-Band Transmit Power** to adjust the power in 1 dB increments as directed by the NOC and selecting **Apply changes** after each increment (see Figure 91). When directed, click **Turn off signal and complete**.

*NOTE: Take note of the P1dB compression value that is also provided by the NOC. You will enter this value later.*

- o. Next, select **BPSK modulation** and enter the **RF uplink frequency** and the **Starting transmit power** (see Figure 92) provided by the NOC. Then click **Turn on signal**.

Figure 90: Commissioning – Step 8: CW Modulation

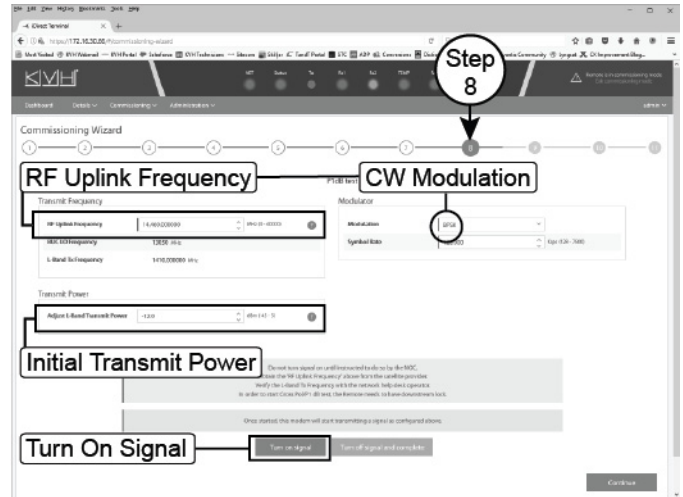

Figure 91: Commissioning – Step 8: CW Modulation continued

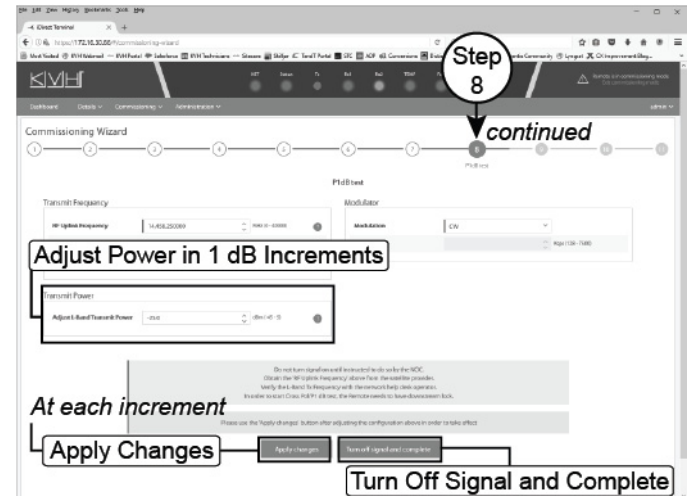
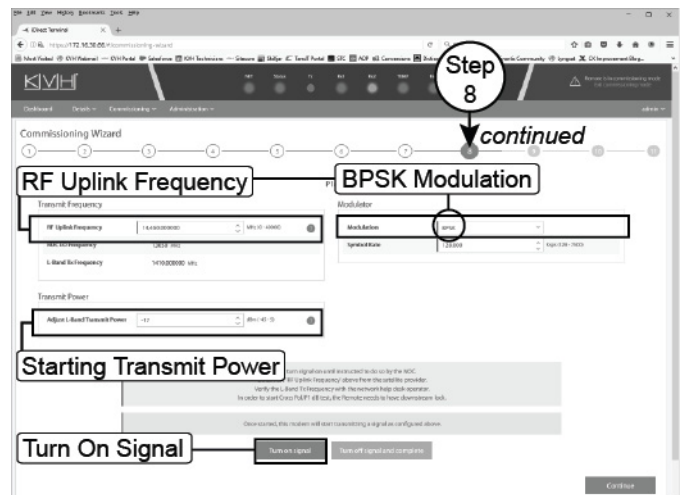

Figure 92: Commissioning – Step 8: BPSK Modulation



# A

# Continued Full Commissioning Steps

## Appendix

- p. Continue by using **Adjust L-Band Transmit Power** to adjust the power in 1 dB increments as directed by the NOC and selecting **Apply changes** after each increment (see Figure 93). When directed, click **Turn off signal and complete**.

*NOTE: Take note of the Maximum transmit (TX) power value provided by the NOC.*

- q. At Step 9, enter the **P1dB** compression value and the **Maximum transmit (TX) power** value provided by the NOC.

### IMPORTANT!

Double-check your entries for the P1dB and Maximum TX Power. Maximum TX Power should **always** be one decibel less than the P1dB value. (For example, if P1dB = -15.0 dB then Max TX power = -16.0 dB.)

Then click **Continue** (see Figure 94)

- r. At Step 10, click **Exit commissioning mode** (see Figure 95).
- s. At Step 11, click **Return to dashboard** (see Figure 95).
- t. Close the modem commissioning wizard. Commissioning is complete!

Figure 93: Commissioning – Step 8: BPSK Modulation *continued*

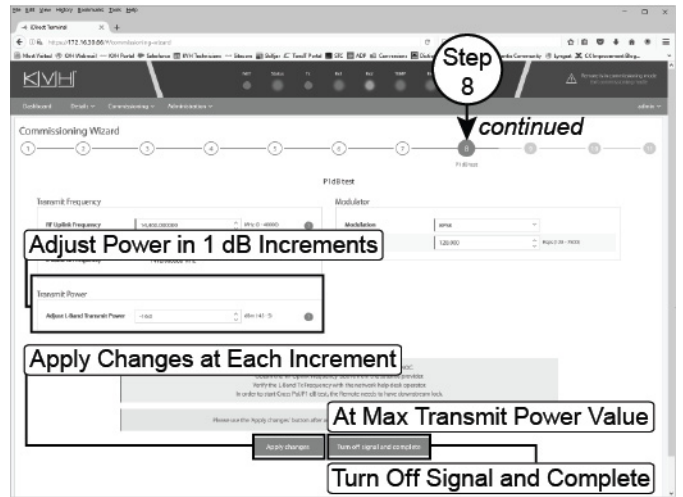

Figure 94: Commissioning – Step 9

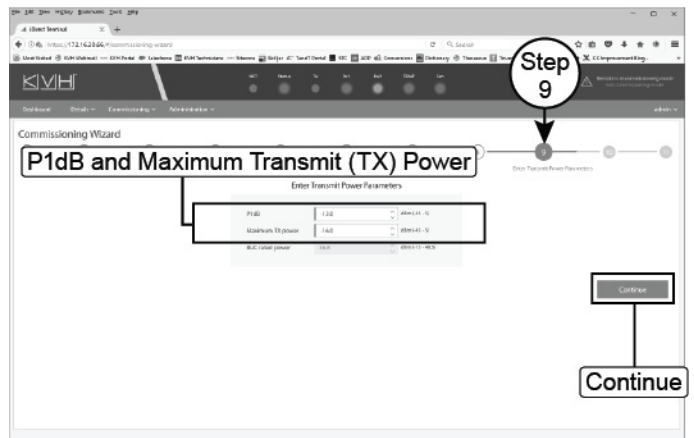
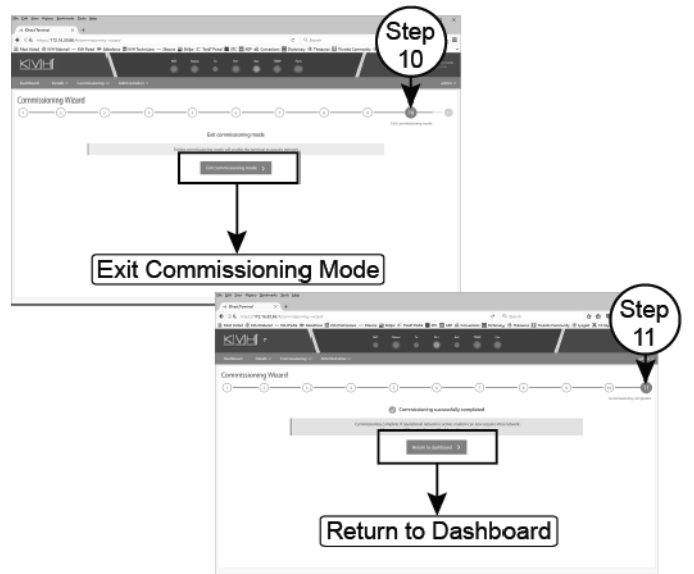

Figure 95: Commissioning – Steps 10 and 11



# B Terminating LMR RF Cables

## Appendix

These instructions explain how to terminate an LMR-400-75 RF cable with an EZ-400-FMH-75 “F” connector using the tools from the TK-400EZ-75 tool kit. The same steps also apply to an LMR-600-75 cable, with the exception of the tools used.

For more detailed instructions, refer to the Times Microwave website: [www.timesmicrowave.com](http://www.timesmicrowave.com).

1. Using the CCT-01 cutting tool, cut the cable evenly (see Figure 96).
2. Since cutting the cable can deform the end, gently round the end of the cable using a pair of needle-nose pliers (see Figure 97). Also make sure the center conductor is centered within the cable.
3. Place the heat shrink sleeve and metal ferrule onto the cable (see Figure 98).
4. Insert the end of the cable into the #1 end of the ST-400EZ stripping tool (see Figure 99). Then rotate the tool clockwise around the cable until the tool turns easily. The end of the cable should now be stripped to expose the center conductor.

Figure 96: Cutting the Cable



Figure 97: Reshaping the Cable

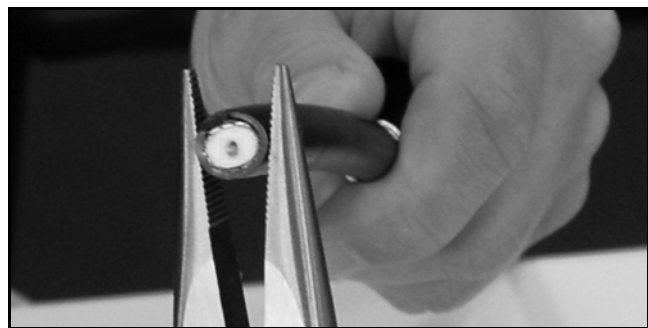

Figure 98: Placing the Heat Shrink Tubing and Ferrule

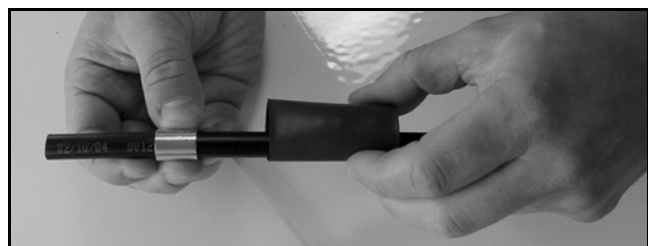

Figure 99: Stripping the End to Expose the Center Conductor



# **B** Continued Terminating LMR RF Cables

## Appendix

5. Using a utility knife, carefully remove any residual plastic from the center conductor, if necessary (see Figure 100).
6. Insert the end of the cable into the #2 end of the ST-400EZ stripping tool (see Figure 101). Then rotate the tool clockwise around the cable until the tool turns easily. This removes the cable jacket from the end of the cable, exposing the braid and dielectric (see Figure 102).
7. Using the DBT-02 tool, deburr and chamfer the center conductor (see Figure 103). Avoid nicking the aluminum tape covering the dielectric.

Figure 100: Removing Plastic Residue

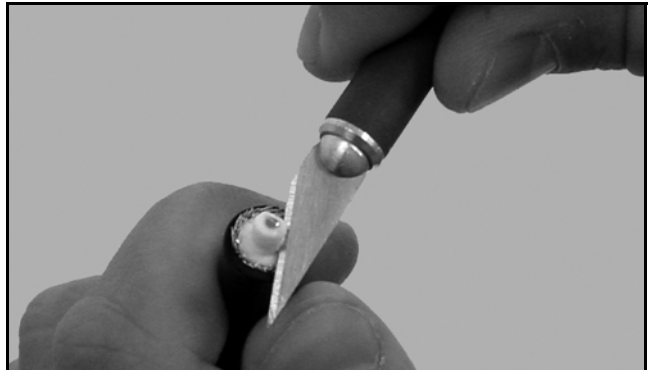

Figure 101: Stripping the Cable Jacket

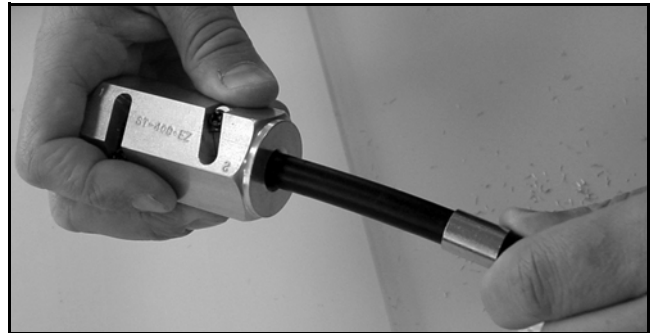

Figure 102: Cable Stripped, Exposing Dielectric



Figure 103: Deburring the Center Conductor



# B

## Continued Terminating LMR RF Cables

### Appendix

8. Gently flare the braid with your fingers (see Figure 104).
9. Insert the end of the cable into the connector body until the dielectric is firmly seated inside the connector (see Figure 105). Make sure there is no gap between the knurled end of the connector and the cable jacket. Also be sure all braid wires remain on the outside of the connector.

#### **IMPORTANT!**

A common installation failure occurs when the connector is not seated properly onto the cable. In these cases, the cable's center conductor does not fully engage the electrical contacts inside the connector. To ensure full engagement, make certain that there is no gap between the cable jacket and the knurled end of the connector before you crimp on the ferrule. You may need to deburr and center the end of the conductor to achieve a good fit.

10. Trim any excess braid (see Figure 106), if necessary. The braid should assemble flush to within 1/16" (1.6 mm) of the connector shoulder.
11. Slide the ferrule over the braid until it is flush against the connector shoulder (see Figure 107). Make sure there are no exposed strands of braid with the ferrule in place.

Figure 104: Flaring the Braid



Figure 105: Pushing On the Connector

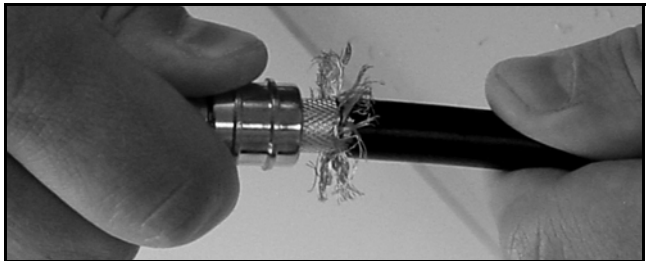

Figure 106: Trimming the Braid

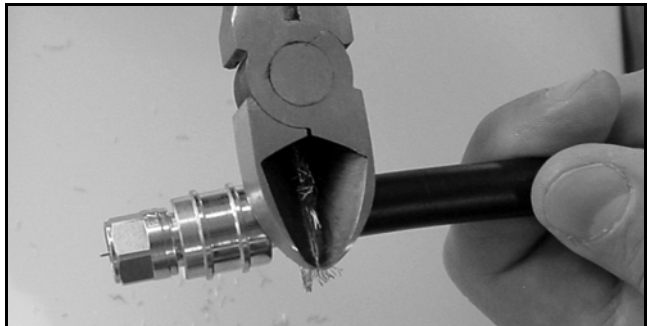
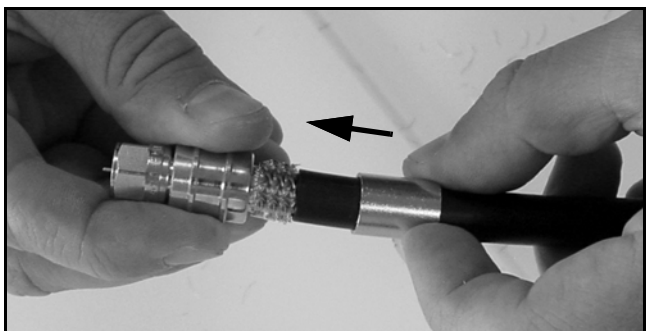

Figure 107: Sliding the Ferrule Over the Braid



# B Continued Terminating LMR RF Cables

## Appendix

12. Using an appropriate crimp tool (either the CT-400/300 or the HX-4 with Y1719 dies), crimp the ferrule in place (see Figure 108). Crimp as close to the connector body as possible.
13. Crimp the ferrule again, but further back from the connector. However, be careful not to crimp the cable jacket.
14. Slide the heat shrink sleeve over the connector body and heat it to compress it into place (see Figure 109). When you are done, the heat shrink should extend from the rear of the connector to the cable jacket. This forms a weather-tight seal.
15. Using a multimeter or similar device, check the continuity of the cable.
16. Ensure the center conductor pin measures between 0.20" and 0.28" (5-7 mm) in length, to ensure proper engagement with the mating connector (see Figure 110).

Figure 108: Crimping the Ferrule onto the Cable

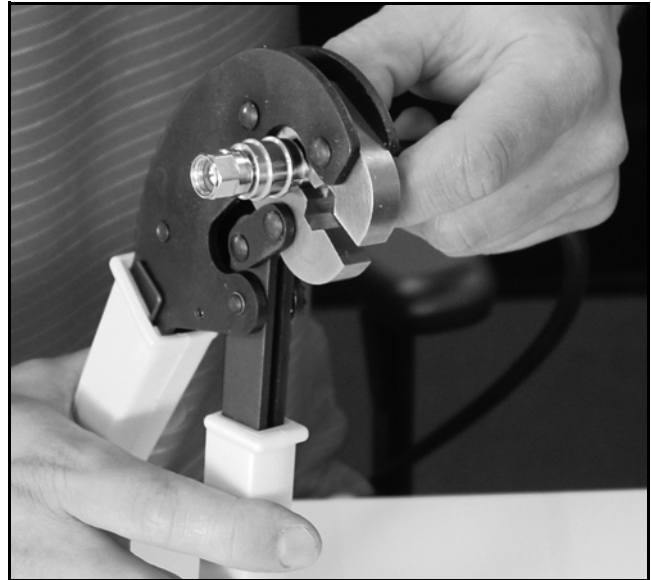
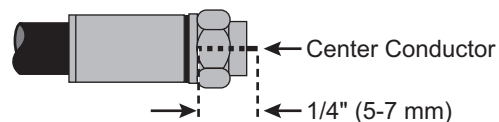

Figure 109: Applying the Heat Shrink Tubing



Figure 110: Proper Center Conductor Pin Length



# C

# Configuring Computers for DHCP

## Appendix

Follow these steps to configure your computer for DHCP to allow it to receive an IP address from the ICM. The location of this configuration setting varies slightly by operating system.

*NOTE: The computer must have a network interface card installed and all cabling must be 100 Mbps fast Ethernet UTP CAT-5 with RJ45 connectors.*

### Windows 10

1. Turn on the computer.
2. Open the **Network and Sharing Center**. The easiest way to get there is to simply enter the name in the search box on the taskbar. *You can also navigate to it from the Start menu: Settings > Network & Internet > Ethernet > Network and Sharing Center.*
3. In the Network and Sharing Center, click the **Ethernet** link for the Ethernet connection you are using.
4. In the Ethernet Status dialog box, click **Properties**. *If this screen doesn't appear, skip to Step 5.*
5. In the Ethernet Properties dialog box, on the **Networking** tab, select **Internet Protocol Version 4**, and then click **Properties**.
6. In the Internet Protocol Properties dialog box, select **Obtain an IP address automatically** and **Obtain DNS server address automatically** (see Figure 111). Then click **OK**.
7. In the Ethernet Properties dialog box, click **Close**. Then click **Close** in the Ethernet Status dialog box.

Figure 111: Windows 10 - Internet Protocol Properties

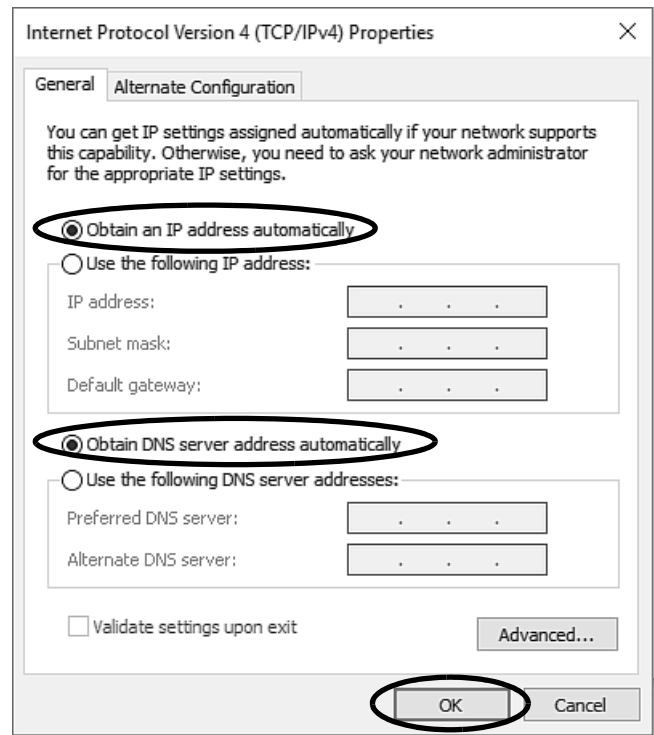

### Windows 8

1. Turn on the computer.
2. In the Control Panel, double-click **Network and Sharing Center**. *To open the Control Panel, go to the desktop, select Settings from the Charms bar, then select Control Panel.*
3. In the Network and Sharing Center, double-click the **Ethernet** link for the Ethernet connection you are using.
4. In the Ethernet Status dialog box, click **Properties**. *If this screen doesn't appear, skip to Step 5.*
5. In the Ethernet Properties dialog box, on the **Networking** tab, select **Internet Protocol Version 4**, and then click **Properties**.
6. In the Internet Protocol Properties dialog box, select **Obtain an IP address automatically** and **Obtain DNS server address automatically** (see Figure 112). Then click **OK**.
7. In the Ethernet Properties dialog box, click **Close**.

Figure 112: Windows 8 - Internet Protocol Properties

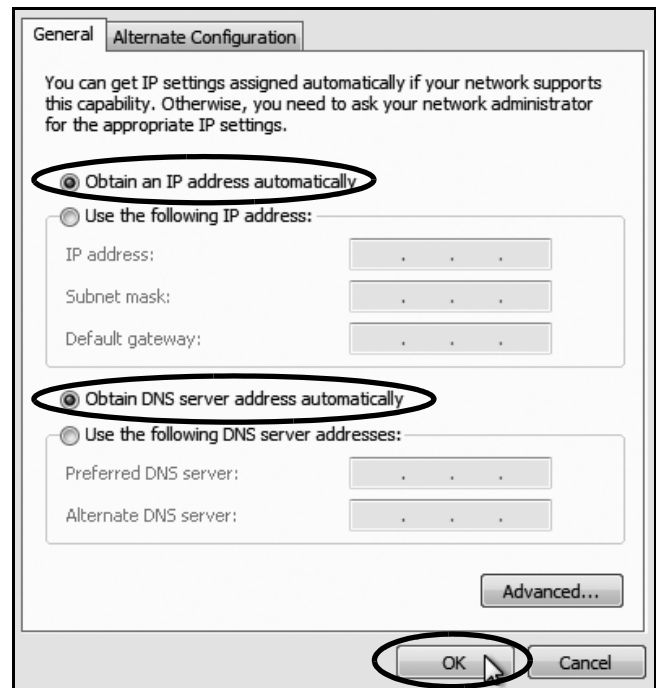

### Windows 7 or Windows Vista

1. Turn on the computer.
2. In the Control Panel, double-click **Network and Sharing Center**. (You might need to click **Network and Internet** first.) *You can find the control panel either through the Start menu or "My Computer."*
3. In the Network and Sharing Center, double-click the **Local Area Connection** link (Windows 7) or **View Status** link (Windows Vista) for the Ethernet connection you are using.
4. In the Local Area Connection Status dialog box, click **Properties**. *If this screen doesn't appear, skip to Step 5.*
5. In the Local Area Connection Properties dialog box, click the **Networking** tab, select **Internet Protocol Version 4**, and then click **Properties**.
6. In the Internet Protocol Properties dialog box, select **Obtain an IP address automatically** and **Obtain DNS server address automatically** (see Figure 113). Then click **OK**.
7. In the Local Area Connection Properties dialog box, click **OK**.

Figure 113: Windows 7/Windows Vista- Internet Protocol Properties

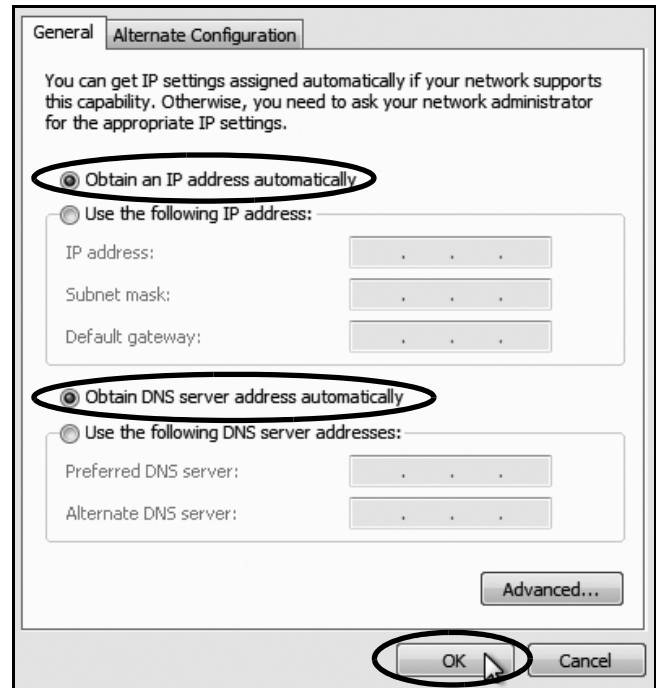

# C

# Continued Configuring Computers for DHCP

## Appendix

### Windows XP

1. Turn on the computer.
2. In the Control Panel, double-click **Network Connections**. *You can find the control panel either through the Start menu or "My Computer."*
3. In the Network Connections, double-click the **Local Area Connection** for the Ethernet connection you are using.
4. In the Local Area Connection Status dialog box, click the **General** tab. Then click **Properties**. *If this screen doesn't appear, just skip to Step 5.*
5. In the Local Area Connection Properties dialog box, click the **General** tab, select **Internet Protocol (TCP/IP)**, and then click **Properties**.
6. In the Internet Protocol (TCP/IP) Properties dialog box, click the **General** tab. Then select **Obtain an IP address automatically** and **Obtain DNS server address automatically** (see Figure 114). Then click **OK**.
7. In the Local Area Connection Properties dialog box, click **OK**.
8. Restart the computer.

Figure 114: Windows XP - Internet Protocol (TCP/IP) Properties

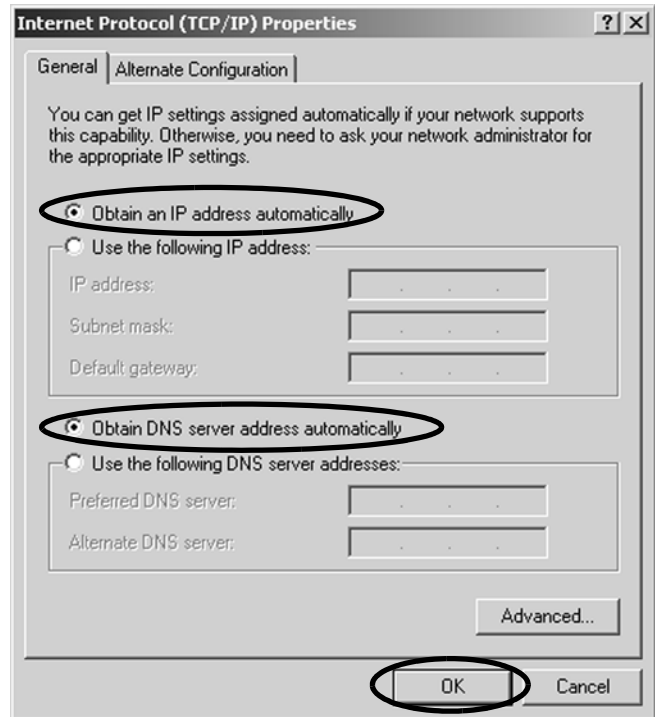

# C

# Continued Configuring Computers for DHCP

## Appendix

### Macintosh OS X

1. Turn on the computer.
2. In System Preferences, click **Network**.
3. In the Network dialog box, select **Ethernet** then set the following:
  - Location: **Automatic**
  - Configure IPv4: **Using DHCP**
4. Click **Apply**.
5. Restart the computer.

Figure 115: Macintosh OS X - Network Preferences

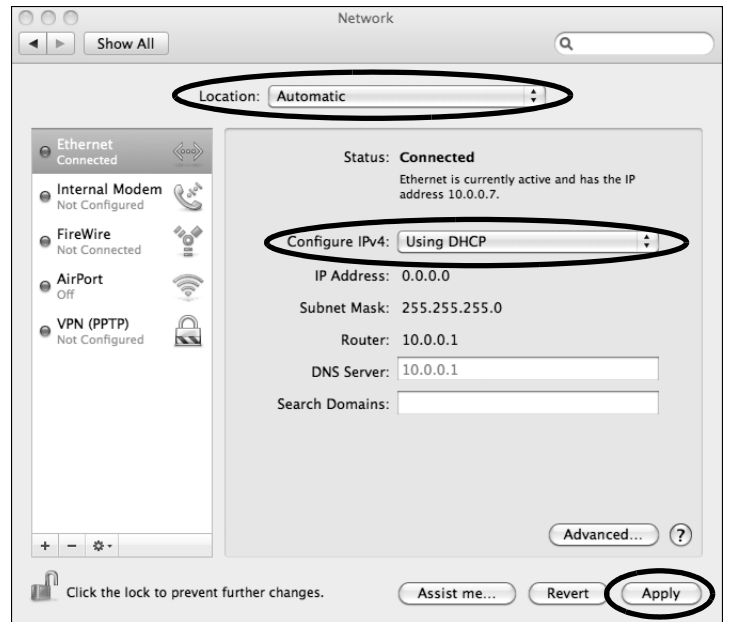

# D Verifying the NMEA 0183 Message

## Appendix

Verify the message supplied by the NMEA 0183 talker by connecting its output to a laptop using an RS422-to-USB adapter cable and viewing its data stream using PuTTY, HyperTerminal, or other terminal emulator. Follow the steps below to verify the message.

*NOTE: These example instructions assume you will be using PuTTY to enter antenna commands.*

1. Using an RS422-to-USB adapter, connect the NMEA 0183 talker to the adapter's RS422 input. Then connect the adapter to your laptop's USB port (see Figure 116).
2. Start PuTTY and specify your laptop's port, connection type, and baud rate (see Figure 117).
3. Configure options at the **Serial** configuration menu as follows (see Figure 118):
  - 4800 baud
  - 8 data bits
  - 1 stop bit
  - no parity
  - no flow control
4. Select **Open** to view the message data in a command line window (see Figure 119).

Figure 116: Connecting a NMEA 0183 Talker to a Laptop

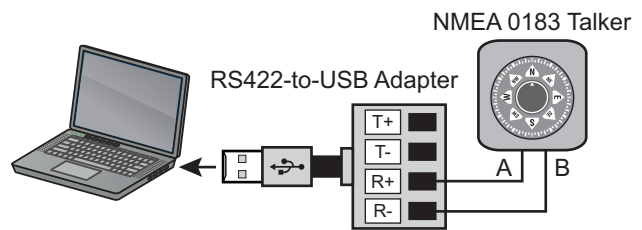

Figure 117: PuTTY Port Configuration Options (Example)

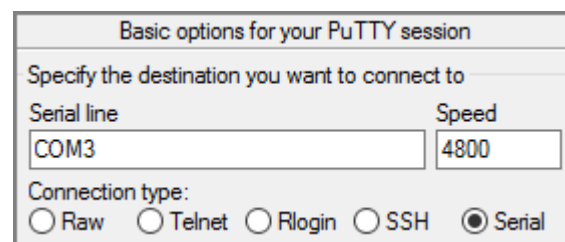

Figure 118: PuTTY Serial Configuration Options (Example)

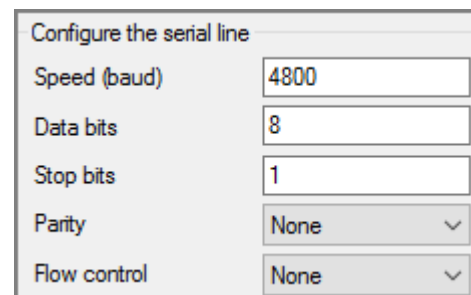
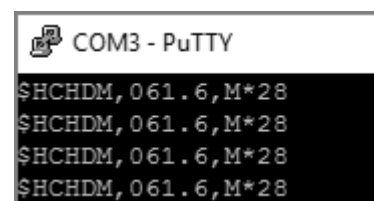
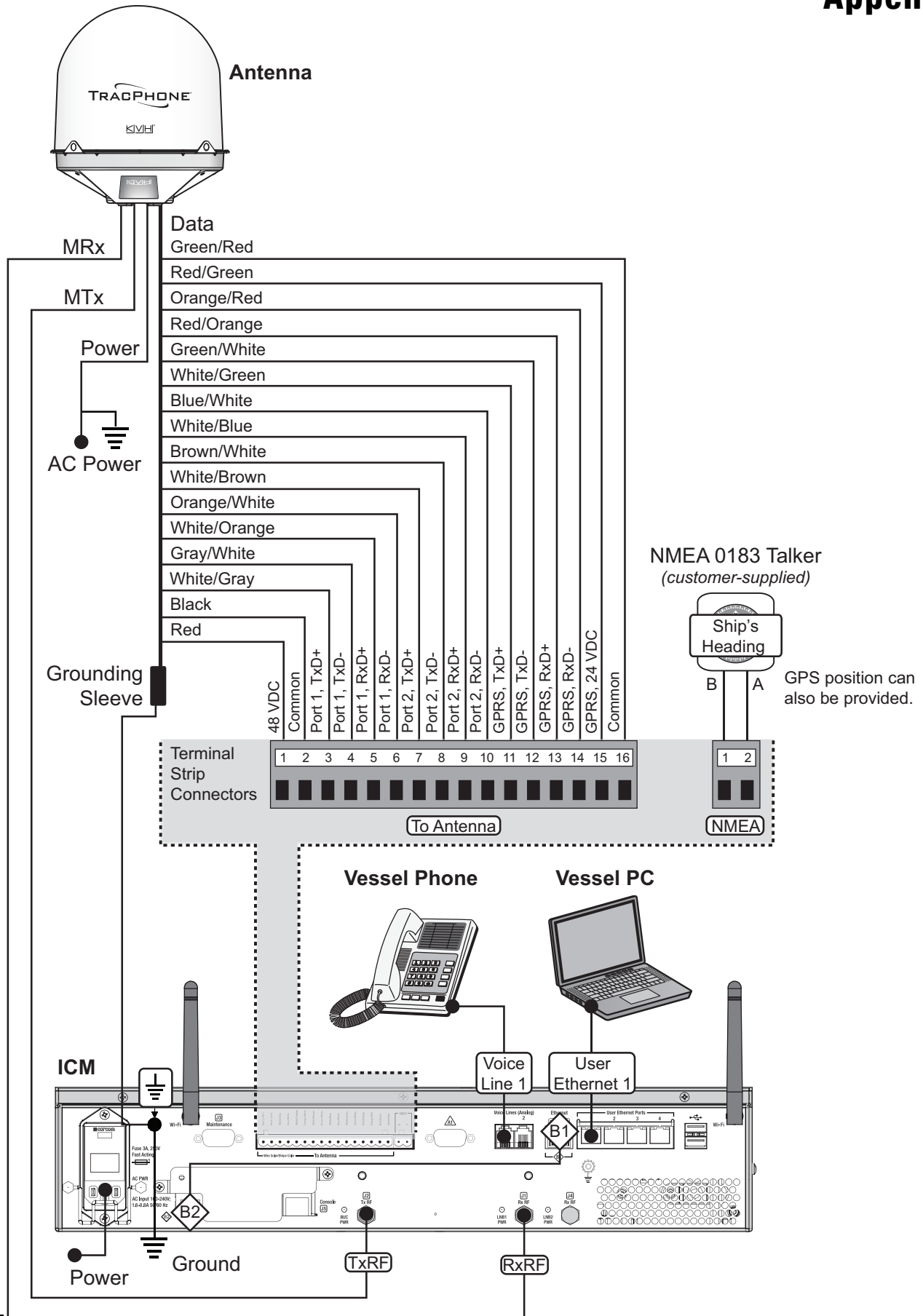

Figure 119: PuTTY Command Line Window (Example)



# E Wiring Diagram





## Regulatory Compliance

### European Union Compliance

Hereby, KVH Industries, Inc. declares that the radio equipment type TracPhone V11-HTS is in compliance with Directive 2014/53/EU. For the full text of the EU Declaration of Conformity, go to [www.kvh.com/euconformity](http://www.kvh.com/euconformity).

### Federal Communications Commission Compliance



The TracPhone system complies with Class B of Part 15 of the FCC (Federal Communications Commission) rules for radiated and conducted emissions.

FCC Identifiers: QIP-EHS6 (antenna 3G Modem)  
PPD-AR5B97 (ICM WiFi)

#### Use Conditions:

This device complies with part 15 of the FCC Rules. Operation is subject to the following two conditions:

1. This device may not cause harmful interference.
2. This device must accept any interference received, including interference that may cause undesired operation.

#### Note:

This equipment has been tested and found to comply with the limits for a Class B digital device, pursuant to Part 15 of the FCC Rules. These limits are designed to provide reasonable protection against harmful interference in a residential installation. This equipment generates, uses, and can radiate radio frequency energy and, if not installed and used in accordance with the instructions, may cause harmful interference to radio communications. However, there is no guarantee that interference will not occur in a particular installation. To determine if the equipment is interfering with radio or television reception, remove or apply power to the equipment and observe if the interference goes away, or returns, when the unit is off or on. The user is encouraged to try to correct the interference by one of the following measures:

- Reorient or relocate the receiving antenna.
- Increase the separation between the equipment and receiver.
- Connect the equipment into an outlet on a circuit different from that to which the receiver is connected.
- Consult KVH for assistance.

#### IMPORTANT:

- To meet FCC requirements, shielded Ethernet cables are required to connect the ICM to the ship's network.
- This equipment contains no user serviceable parts. Opening this unit will violate the warranty and may result in this equipment no longer complying with FCC requirements for Class B digital devices.



**CE**

**UK  
CA**



[www.kvh.com](http://www.kvh.com)



---

**KVH Industries A/S**  
*EMEA Headquarters*  
Birkerød, Denmark  
Tel: +45.45.160.180 Fax: +45.45.160.181  
Email: [info@emea.kvh.com](mailto:info@emea.kvh.com)

**KVH Industries, Inc.**  
*World Headquarters*  
Middletown, RI U.S.A.  
Tel: +1.401.847.3327 Fax: +1.401.849.0045  
Email: [info@kvh.com](mailto:info@kvh.com)

**KVH Industries Pte Ltd.**  
*Asia-Pacific Headquarters*  
Singapore  
Tel: +65.6513.0290 Fax: +65.6472.3469  
Email: [info@apac.kvh.com](mailto:info@apac.kvh.com)