

KVH Industries, Inc.

TracVision® UHD7

TracPhone® V7HTS Matching Dome Configuration



Installation Guide

TracVision UHD7 Installation Guide

TracPhone® V7HTS-Matching Dome Configuration

This guide explains how to install the TracVision UHD7 satellite TV antenna system on a vessel. Operation instructions are provided in the Help.

Installation Steps

1. Inspect Parts and Get Tools	3	12. Wire the Receivers.....	15
2. Plan the Antenna Installation	4	13. Connect a NMEA Device	20
3. Plan the TV-Hub Installation.....	6	14. Connect Power.....	21
4. Prepare the Antenna Site.....	7	15. Turn On the System	23
5. Prepare the RF Cables.....	8	16. Access the Web Interface.....	24
6. Remove the Radome	9	17. Connect to an Onboard Network.....	25
7. Remove the Shipping Restraints.....	10	18. Secure the Wi-Fi Connection	26
8. Wire the Antenna	11	19. Set Up the System.....	27
9. Mount the Antenna	12	20. Configure SWM Receivers/DVRs	29
10. Mount the TV-Hub.....	13	21. Run a Check Switch Test.....	30
11. Wire the TV-Hub.....	14	22. Educate the Customer.....	31

Who Should Install the System?

To ensure a safe and effective installation, KVH recommends that a KVH-authorized marine technician install the TracVision antenna. KVH-authorized technicians have the tools and electronics expertise necessary to install the system. To find a technician near you, visit www.kvh.com/wheretogetservice.

Technical Support

If you need technical assistance, please contact KVH Technical Support:

North/South America, Australasia

Phone: +1 401 847-3327

Email: support@kvh.com

(Mon.-Fri., 9 am-6 pm; Sat., 9 am-2 pm ET, -5 GMT)

Europe, Middle East, Africa, Asia-Pacific

Phone: +45 45 160 180

Email: support@kvh.com

(Mon.-Thu., 8 am-4:30 pm; Fri., 8 am-2 pm, +1 GMT)

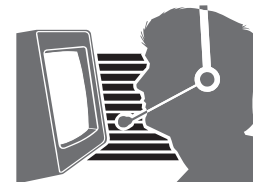

KVH, TracVision, TracPhone, and the unique light-colored dome with dark contrasting baseplate (Reg. No. 2,864,752) are registered trademarks of KVH Industries, Inc. All other trademarks are property of their respective companies. The information in this document is subject to change without notice. No company shall be liable for errors contained herein.

©2019-2021 KVH Industries, Inc., All rights reserved. 54-1306 Rev. C1 | 72-0870

Important Safety Information



This icon indicates a danger, warning, or caution notice. Be sure to read these carefully to avoid injury.



WARNING

Risk of Electric Shock

To avoid electric shock, do not open the TV-Hub chassis enclosure. There are no user-serviceable parts inside.



WARNING

Risk of Electric Shock

If any component of the TracVision system becomes damaged and/or no longer functions normally, disconnect it from vessel power, secure it from unintended operation, and contact KVH Technical Support (see [“Technical Support” on page 1](#)). All repairs or modifications must be performed by a trained, KVH-certified technician. If you are a KVH-certified technician, you still must contact KVH Technical Support prior to conducting any repairs or modifications to the equipment.



WARNING

Risk of Explosion

Do not operate the TV-Hub (or any other electrical device) in an environment where flammable gases, vapors, or dusts are present. In addition, do not operate the TV-Hub in an environment with a temperature outside its 5° F to 131° F (-15° C to 55° C) temperature range.



WARNING

Risk of Electric Shock

Failure to ground the TracVision system properly to ship's ground will cause an unsafe floating ground condition, risking potentially lethal electric shock. See [“Connect Power” on page 21](#) for details on the proper grounding of the equipment.

1 Inspect Parts and Get Tools

Before you begin, follow these steps to ensure you have everything needed to complete the installation.

IMPORTANT!

Always lift the antenna by the baseplate or the hoist holes in the internal frame, and never by the radome or any other portion of the internal antenna assembly (see Figure 1).

- a. Unpack the box and ensure it contains everything shown on the Kitpack Contents List. Save the packaging for future use.
- b. Carefully examine all of the supplied parts to ensure nothing was damaged in shipment.
- c. Gather the tools and materials listed below. You will need these items to complete the installation.
 - Flat-head and Phillips-head screwdrivers
 - Electric drill and 5/8" (16 mm) and 1/8" (3 mm) drill bits
 - 3.75" (95 mm) hole saw
 - 9/16" and 3/4" socket wrenches
 - 7/16" open-end torque wrench set to 15 in.-lbs (1.7 N-m) and 20 in.-lbs (2.25 N-m)
 - Socket wrenches
 - Light hammer and center punch
 - Adhesive tape and scribe or pencil
 - RG-6 or RG-11 RF coax cables, with "F" connectors, and termination tools (see [page 8](#))
 - Silicone sealant or equivalent
 - Additional SWM splitters, as required
 - Satellite TV receiver(s)/DVR(s) for your desired service (see Figure 2)
 - Multimeter
 - Wi-Fi-enabled laptop PC Apple® iOS or Android™ smartphone/tablet with the KVH TracVision TV-series/UHD7/RV1/A9 app, and the latest software and satellite library downloaded from the KVH Partner Portal (www.kvh.com/partners)

Figure 1: TracVision UHD7 System Components

Antenna

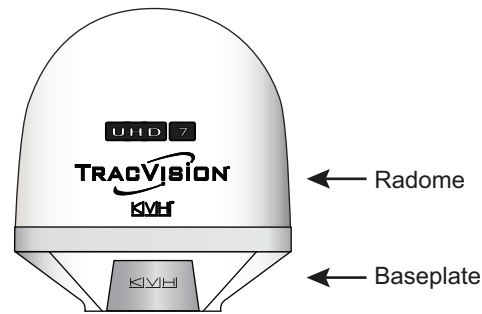

TV-Hub

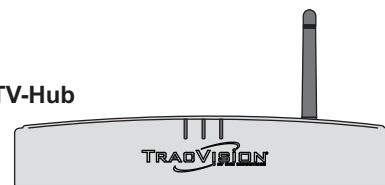

Figure 2: KVH-Validated Receivers

DIRECTV*		DISH Network*
H20	HR23	311
H21	HR24	211
H22	HR34	211k
H23	HR44	211z
H24	HR54	Wally
H25		
H44		
HR21		
HR21 Pro		
HR22		
		Bell TV*
		6100
		6131
		6400

* List is subject to change. For information on connecting different receiver models, contact KVH Technical Support.

2 Plan the Antenna Installation

Before you begin, consider the following antenna installation guidelines.

IMPORTANT!

Be sure to follow the guidelines below. Damage caused by an improper installation is not covered under KVH warranty.

- Minimize blockage. The antenna requires a clear view of the sky to receive satellite TV (see Figure 3). The fewer obstructions, the better the system will perform.
- Consider the distance between your antenna and any radar. KVH requires that you do not mount the antenna on the same level as the radar because the radar's energy may damage the LNB. Most radar transmitters emit RF energy within an elevation range of -15° to $+15^\circ$ (see Figure 4). Therefore, mount the antenna outside of this elevation range and at least 3 ft (1 m) away from the radar.

IMPORTANT!

Never place the antenna in the beam path of the radar, regardless of distance. The radar's energy may damage the antenna or impair its performance.

Figure 3: Blockage from Obstruction

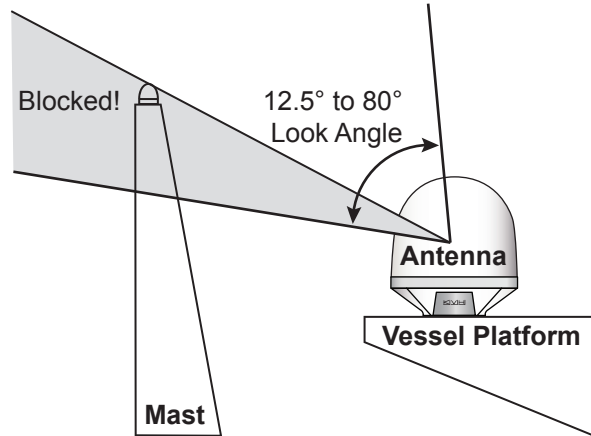
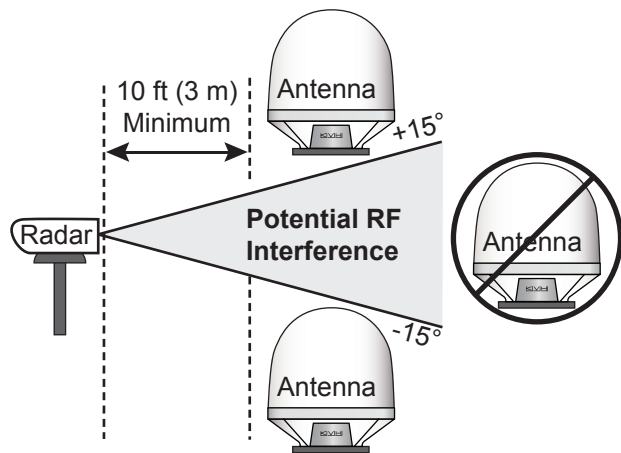

Figure 4: Distance from Radar



2 Continued Plan the Antenna Installation

- Make sure the mounting surface is wide enough to accommodate the antenna's base (see Figure 5). Also make sure it is flat, level (within $\pm 1^\circ$), strong enough to support the antenna's weight (approx. 61 lbs, 27.4 kg), and rigid enough to prevent antenna vibration.
- Select a location that is as close as possible to the intersection of the vessel's fore-and-aft centerline and midships.
- Be sure to mount the antenna near enough to the TV-Hub to allow you to connect the 100 ft (30 m) coax cables between them, while still maintaining sufficient service loops in the cables.

NOTE: If you need to use a longer cable, use a RG-11 (75 Ω) cable that does not exceed 200 ft (60 m) in length (see "Prepare the RF Cables" on page 8).

Figure 5: Antenna Dimensions

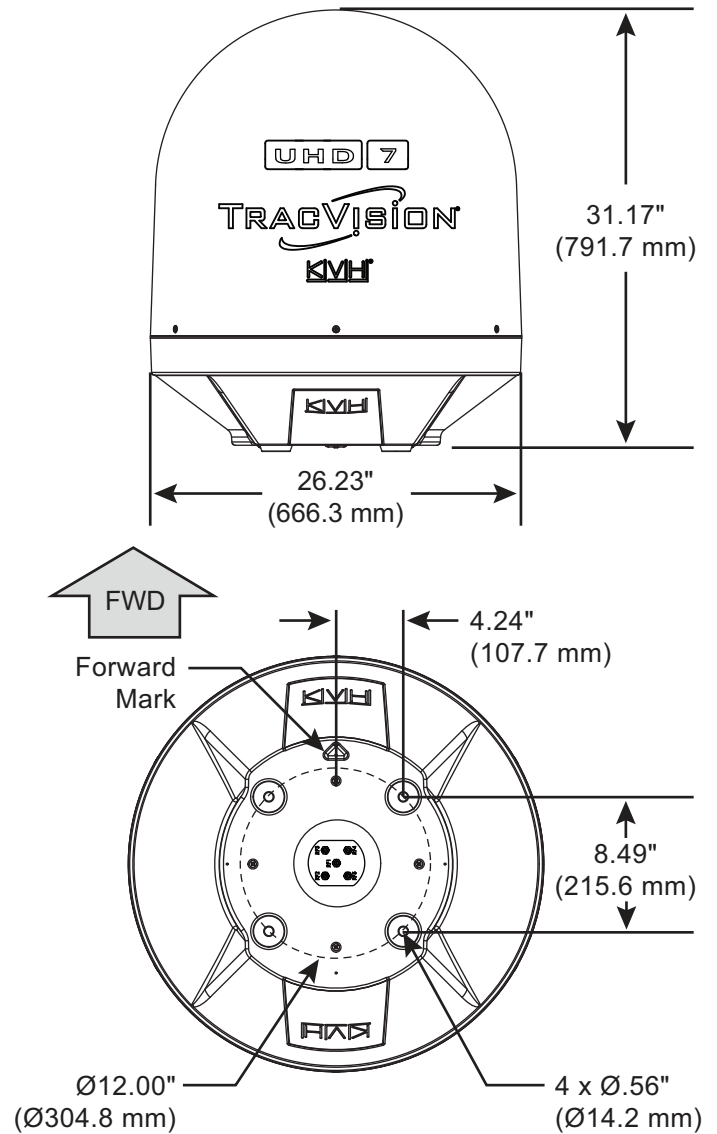

3 Plan the TV-Hub Installation

Consider the following TV-Hub installation guidelines.

- Select a mounting location in a dry, well-ventilated area belowdecks away from any heat sources or salt spray.
- Do not install the TV-Hub in an area surrounded by metal or near any electrical devices that emit RF noise.
- The TV-Hub can be mounted horizontally or vertically on a flat surface (see Figure 6 and Figure 7).
- Be sure the TV-Hub LED lights will be visible to the user.
- Select a location that will provide adequate clearance for the TV-Hub dimensions (see Figure 6 and Figure 7).
- Leave enough room behind the rear panel (horizontal mount) or below the rear panel (vertical mount) to accommodate connecting the cables and making service loops within the proper bend radius for strain-relief.
- If you plan to use the TV-Hub's Wi-Fi connections, ensure the TV-Hub mounting location provides adequate Wi-Fi reception.
- If you plan to connect the TV-Hub to the vessel's onboard local area network (LAN), choose a location near an available Ethernet port.

NOTE: A template showing the exact locations of the TV-Hub mounting holes and the dimensions between them is provided in the Welcome Kit. Installation details are provided in ["Mount the TV-Hub"](#) on page 13.

Figure 6: TV-Hub Dimensions - Horizontal Orientation

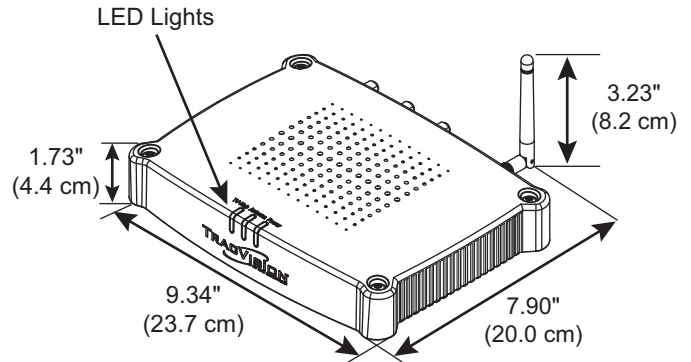
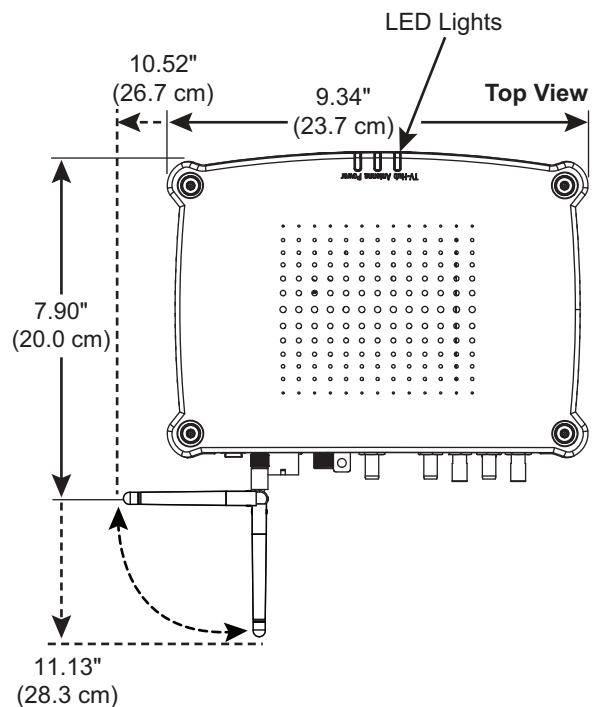

Figure 7: TV-Hub Dimensions - Vertical Orientation



4

Prepare the Antenna Site

Once you have identified a suitable antenna mounting site, according to the guidelines provided on [page 4](#), follow these steps to drill the mounting holes and cable access hole to prepare the site for installation.

- a. Unfold the antenna mounting template (supplied in the Customer Welcome Kit) and place it onto the mounting surface. Make sure the "FWD" (forward) arrow points toward the bow and is **parallel** to the vessel's centerline (see Figure 8). Tape in place.

*NOTE: You don't need to mount the antenna exactly on the vessel's centerline (the closer, the better), but the antenna's forward arrow must be **parallel** to it.*

- b. Using a light hammer and center punch, mark the locations for the four mounting holes and cable access hole on the mounting surface in the locations indicated on the template.
- c. Drill a 5/8" (16 mm) hole at the four mounting hole locations you marked in Step b. Later, you will insert four 1/2"-13 bolts through these holes to secure the antenna to the mounting surface.
- d. Cut out the 3.75" (95 mm) cable access hole in the location you marked in Step b. Smooth the edges of the hole to protect the cables. Later, you will route the RF cables through this hole and into the vessel.
- e. Clean and dry the antenna mounting surface.
- f. Peel off the paper backing from the supplied foam seal to expose the adhesive. Then press the foam seal down firmly onto the mounting surface, ensuring the hole in the foam seal aligns with the cable access hole in the mounting surface (see Figure 8).

Figure 8: Antenna Mounting Holes Layout

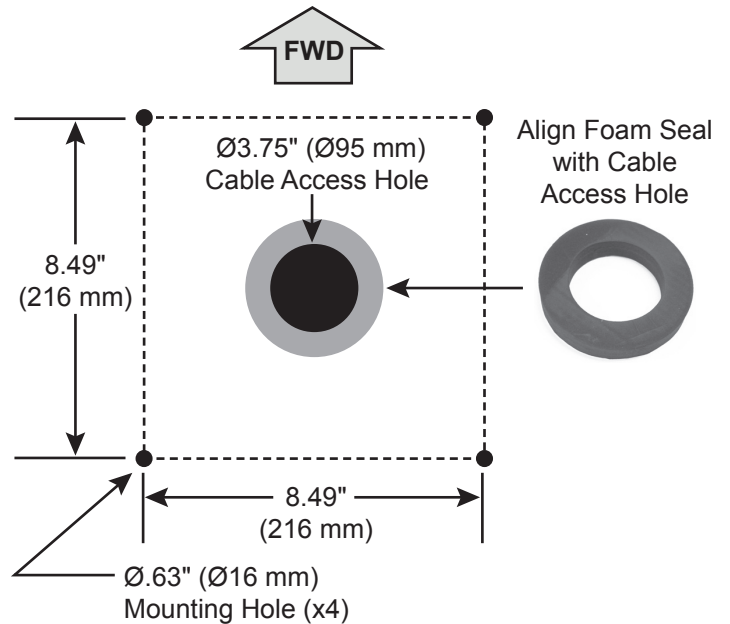

5 Prepare the RF Cables

Determine the necessary type of RF cables and connectors you need for any RF cables that are required in addition to what is supplied in the antenna kit (see Figure 9 and Figure 16 on page 11). Then follow the guidelines below to prepare the cables.

IMPORTANT!

- Do not reuse old RF cables from a previous antenna installation. The RF1 cable between the TV-Hub and the antenna carries not only satellite signal, but power and data as well. Therefore, the integrity and reliability of this cable is critically important.
- RF cables must be rated for 75Ω, not 50Ω.
- Use of any cables not specified in Figure 9 will void the warranty.
- Low-quality, poorly terminated, or improperly installed RF cables are the most common cause of system problems. Terminate all RF cables with high-quality “F” connectors using the proper stripping/crimping tools, exactly to the manufacturer’s specifications.
- When determining cable lengths, be sure to account for an adequate service loop, approximately 8" (20 cm) at both ends of each cable.

Figure 9: RF Cable Requirements

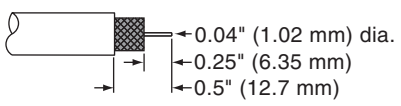
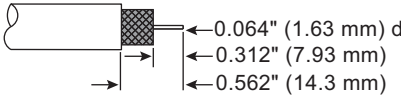
Up to 100 ft (30 m) Cable Run	
Cable	RG-6 (KVH part no. 32-0417-0100)
Connector	Belden SNS1P6 (KVH part no. 23-0170)
Tools	Augat IT1000 (KVH part no. 19-0242)
Strip Lengths	
Up to 200 ft (60 m) Cable Run	
Cable	RG-11 (KVH part no. 32-1272-0200)
Connector	PPC Belden-brand EX Series 11 (PPC part no. EX11N716PLUS) (KVH part no. 23-0917)
Tools	PPC Belden-brand VT-200, Klein Tools 63050, Belden CST596711 or Cablematic® DDT-596/11, Klein 63050 (KVH part no. 72-0493)
Strip Lengths	

Note: LMR-400-75 is a suitable substitute.

6 Remove the Radome

To access the antenna, use a #2 Phillips screwdriver to remove the six #10-32 Phillips screws securing the radome to the baseplate (see Figure 10). Carefully lift the radome straight up until clear of the antenna assembly and set it aside in a safe place.

If you keep the radome topside, secure it with a lanyard to prevent it from falling overboard. Also, do not place the radome on a hot steel deck – the heat may warp the radome.

IMPORTANT!

If necessary, use the two Ø0.5" (12.5 mm) holes in the antenna frame (see Figure 11) to hoist the antenna to its mounting location. **DO NOT** use any other structure inside the antenna — doing so might damage the antenna.

Figure 10: Removing the Radome

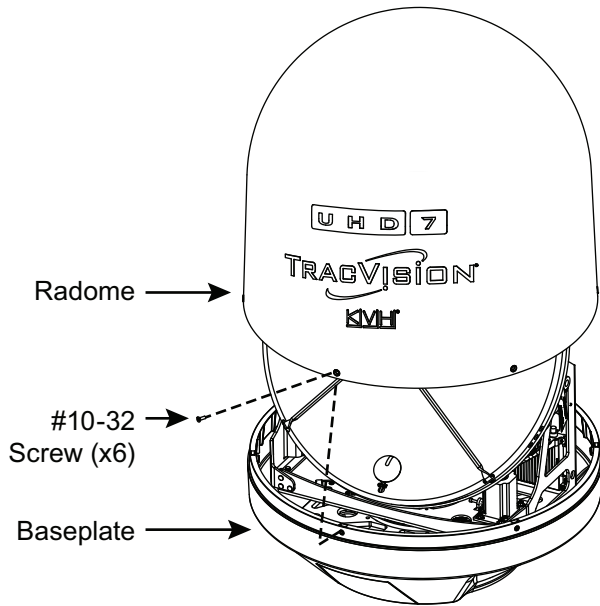
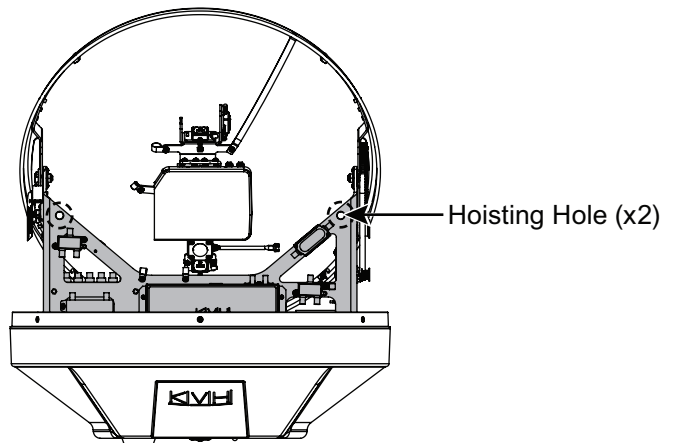

Figure 11: Antenna Hoisting Holes



7 Remove the Shipping Restraints

Follow these steps to remove the shipping restraints from inside the antenna.

IMPORTANT!

Once you have removed the restraints, keep the antenna level as much as possible and handle the antenna very carefully. Prevent the internal antenna assembly from rotating freely within the baseplate to avoid damaging the limit switch.

- a. Using a 9/16" nut driver or wrench, remove the two bolts securing the two shipping restraint brackets to the frame (see Figure 12).

NOTE: Be sure to keep the shipping restraint brackets for future use.

- b. In place of the brackets, place a 3/8" flat washer (supplied in kit) on each of the two 3/8" bolts that you just removed (see Figure 13). Then reinstall the bolts.
- c. Using cutting pliers, cut and remove the two tie-wraps equipped with paper tags (see Figure 14).

Figure 12: Shipping Restraint Bracket Removal

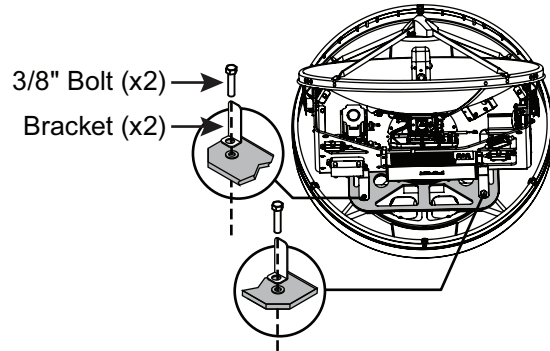

Figure 13: Mounting Bolt Reinstallation

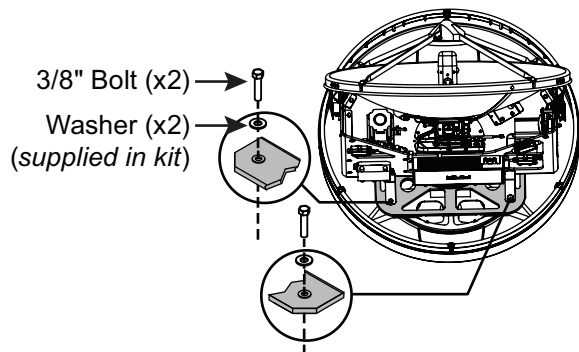
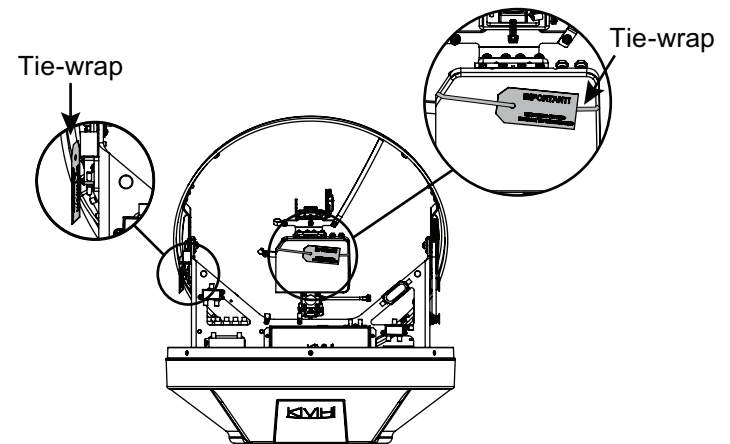



Figure 14: Antenna Restraints



8 Wire the Antenna

Determine the number of tuners the system will need to support and the number of RF cables you will need for your installation (refer to the tables in Figure 15 and Figure 16). Then follow the steps below to connect the cables to the antenna.

- a. Clearly label all RF cables at both ends of each cable to match the connector. This will make it easier to identify them later.
- b. Route the RF cables belowdecks through the 3.75" (95 mm) cable access hole. Leave an adequate service loop, approximately 8" (20 cm) of slack, in the cables for easy serviceability.
- c. Remove the rubber caps from the RF connectors on the bottom of the antenna that you will use (see Figure 17). Leave the caps on all unused connectors.
- d. Clean and dry the connectors on the RF cables and the antenna with a solvent or alcohol.

	CAUTION
<p>Observe the safe handling instructions in the Material Safety Data Sheet (MSDS) provided with the silicone grease.</p>	

- e. Fill half of the inner body of the RF1 cable's connector with the supplied silicone grease.
- f. Connect and **SLOWLY** hand-tighten the RF1 cable to the "RF1" connector on the bottom of the antenna, allowing the grease to diffuse and settle into the entire space within the connector.
- g. Make sure the RF cable is hand-tightened all the way into the connector. Then tighten it with a 7/16" torque wrench to 20 in.-lbs.
- h. Wipe off any excess grease from the outside of the connector.
- i. Repeat steps e-h to connect any additional RF cables to the antenna's RF2-RF5 connectors, as necessary.
- j. Seal the RF cable connections with silicone sealant or equivalent and weatherproof the cable access hole as required.

Figure 15: Number of Tuners Per SWM Device

SWM Device	No. Tuner(s)
SWM Receiver	1
SWM DVR	2
Genie (HR34/HR44)	5
Genie (HR54)	7
Genie Client	0

Figure 16: Number of RF Coax Cables to Connect to Antenna

SWM Tuners	No. Cables	Antenna Connectors
13 or fewer	2	RF1 and RF2
14 or more	3	RF1, RF2, and RF3
27 or more*	5	RF1, RF2, RF3, RF4, and RF5

* Two SWM expansion kits are available for installations that require 27 to 52 tuners (KVH part no. 72-0897) or 53 to 104 tuners (72-0898).

Figure 17: Connectors on Bottom of Antenna

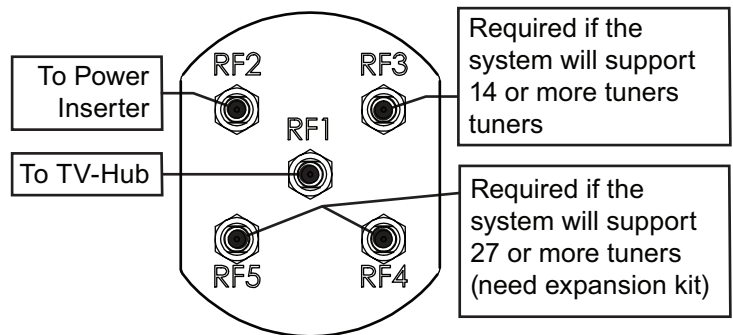

9 Mount the Antenna

Follow these steps to mount the antenna.

- a. Place the antenna over the holes drilled in the mounting surface. Ensure the forward arrow points toward the bow and is **parallel** to the vessel's centerline (see Figure 18).

IMPORTANT!

You will need to rotate the antenna assembly by hand to see all four mounting holes. Rotate it slowly to avoid damaging the limit switch.



CAUTION

Be sure to observe the safe handling instructions in the Material Safety Data Sheet (MSDS) provided with the anti-seize lubricant.

- b. Apply a thin layer of the supplied anti-seize lubricant to the threads of the four 1/2"-13 mounting bolts (see Figure 19).
- c. Using a 3/4" socket, secure the antenna through the baseplate pedestal to the mounting surface using four 1/2"-13 bolts and flat washers from above and flat washers and lock nuts (see Figure 19). Tighten all four bolts until the four rubber feet on the baseplate are bottomed against the mounting surface and the foam seal is fully compressed. KVH recommends that you tighten the bolts to between 25 and 30 ft-lbs (34 and 41 N-m) of torque.
- d. Rotate the antenna through its full range of motion, to ensure there is no interference, and inspect the inside of the antenna to make sure you have not left any tools or debris inside.
- e. Reinstall the radome onto the antenna. Secure it in place with the screws you removed in ["Remove the Radome" on page 9](#). Hide and protect the screws with plastic screw caps (supplied in kit).

Figure 18: Forward Arrow in Antenna Baseplate

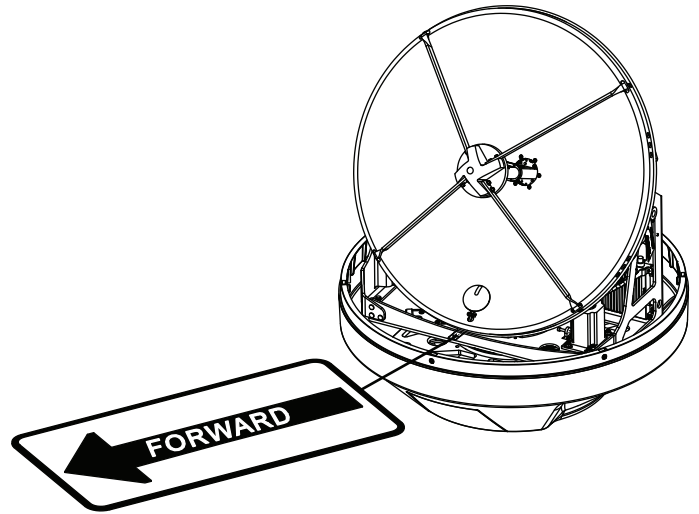
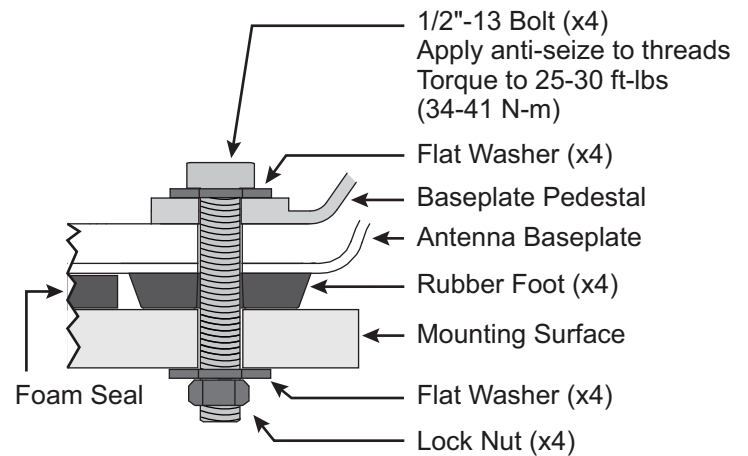

Figure 19: Mounting the Antenna (Side View)



10 Mount the TV-Hub

Follow these steps to install the TV-Hub inside the vessel.

IMPORTANT!

Before continuing, locate the serial number on the bottom of the TV-Hub and record it on the Installation Checklist (supplied in the Welcome Kit) for future reference.

- Tape the mounting template in the location selected for the TV-Hub. Punch holes at each of the two keyhole locations and at the mounting tab location.
- Remove the template.
- Drill a 1/8" (3 mm) hole at the three hole locations you marked in Step a.
- Install a #8 Phillips thread-forming screw partway into one of the keyhole holes leaving a small gap for hooking the TV-Hub onto it. Use the thickness (2.5 mm) of the M10 washer (supplied in kit) as a gauge for the size gap to leave.
- Repeat step d for the other keyhole.
- Peel off the backing on the adhesive-backed washer (supplied in kit) and place it over the mounting tab hole (see Figure 20).
- Align the wide part of the TV-Hub's keyholes, as shown in Figure 21, over the screws, then slide downwards to secure the screws into the narrow part of the keyholes.
- Press the rear mounting tab of the TV-Hub onto the adhesive washer and install the third #8 Phillips thread-forming screw in the mounting tab hole.

Figure 20: TV-Hub Mounting Template

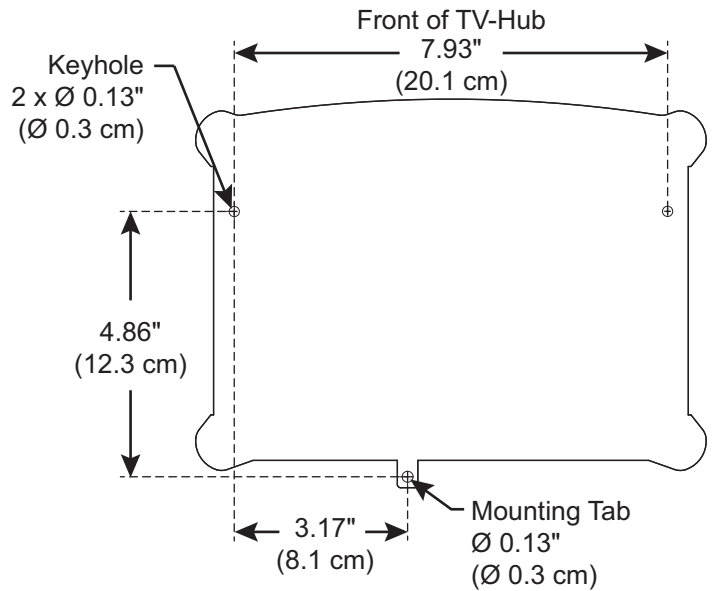
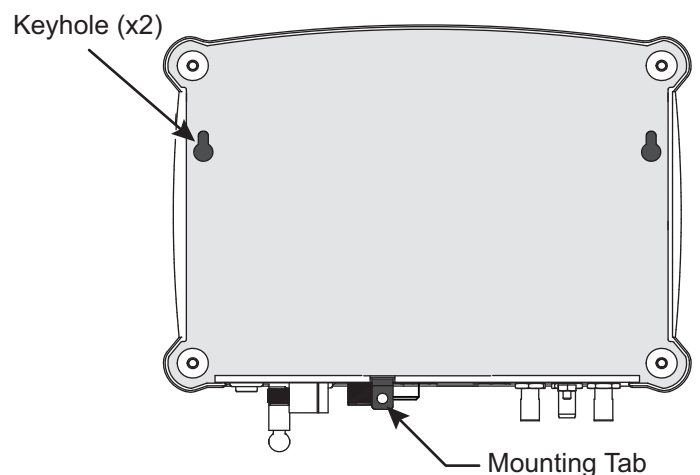

Figure 21: TV-Hub Keyholes and Mounting Tab



11 Wire the TV-Hub

Follow these steps to connect the antenna cables to the belowdecks equipment.

- a. Connect a grounding block in-line with each RF cable from the antenna (see Figure 22 and “Grounding Requirements” on page 21).
- b. Connect the RF1 cable from the antenna to the “Antenna” jack on the TV-Hub (see Figure 22).

IMPORTANT!

Do not connect anything other than the antenna’s RF1 cable to the “Antenna” jack. The TV-Hub supplies voltage that will damage other devices, such as multiswitches, receivers, DVRs, etc.

- c. Hand-tighten the RF cable until it is all the way into the “Antenna” jack. Then tighten it with a 7/16” torque wrench set to 15 in.-lbs.
- d. Connect the RF2 cable from the antenna to the “Power to SWM” connector on the SWM power inserter (see Figure 22).
- e. Using fasteners appropriate for the mounting surface, secure the power inserter to the mounting surface.

NOTE: Do not connect the SWM power inserter’s AC power cable to vessel power at this time. Power will be connected in “Connect Power” on page 21.

Figure 22: TV-Hub Antenna Connection

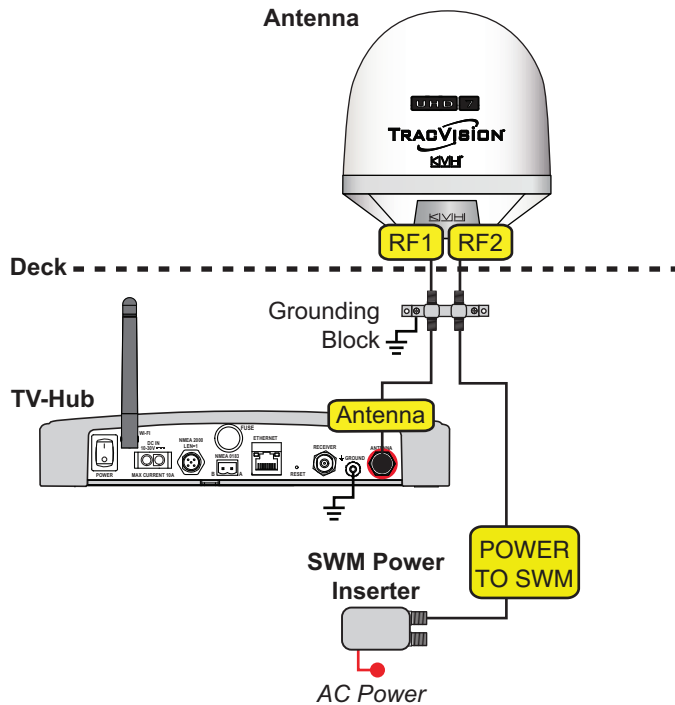

12 Wire the Receivers

The steps for connecting the customer's receiver(s) to the TracVision system and setting them up depends upon the customer's satellite TV service.

Follow the steps in the applicable section below to wire the receivers. Then connect the receiver(s) to the customer's television(s).

IMPORTANT!

If you have any DISH/Bell receiver(s) other than a Wally, during setup, you will need to temporarily connect the receiver(s), one at a time, directly to the "Receiver" port on the TV-Hub and run a Check Switch test. Refer to "Run a Check Switch Test" on page 30 or to the Help for more details.

DIRECTV (SWM) Wiring page 16

DISH Network/Bell TV Wiring . . page 19

NOTE: The DISH Network/Bell TV section includes steps to connect most non-Wally DISH receivers. To connect Wally receivers, refer to "Using Wally Receivers" on page 32.

Figure 23: Receiver/DVR Wiring

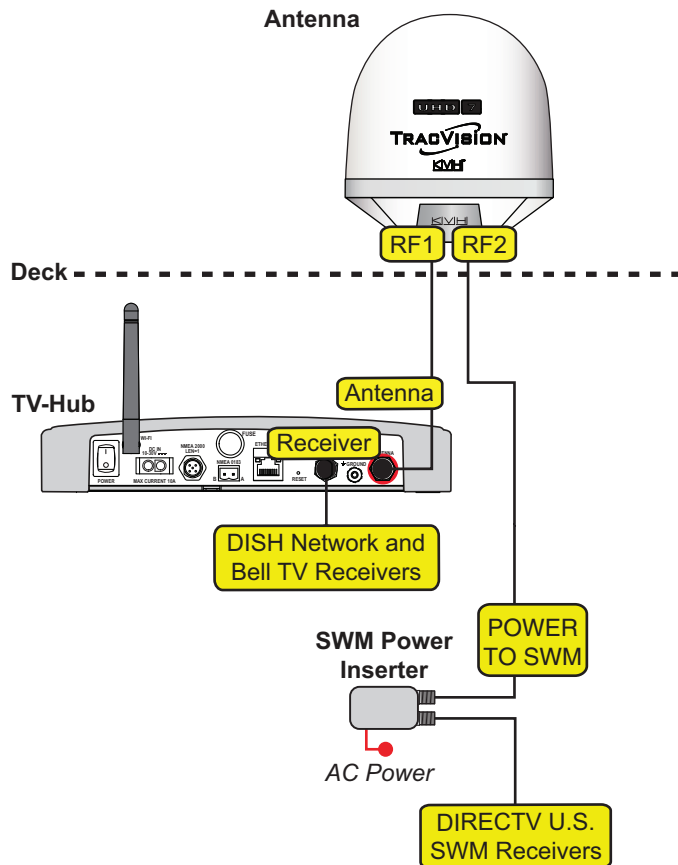

Note: The system does not support DIRECTV non-SWM receivers.

12 Continued Wire the Receivers

DIRECTV – SWM Wiring

Follow these steps to connect DIRECTV receivers to the TracVision system.

Connecting 1 SWM Receiver/DVR

Connect an RF cable from the “Signal to IRD” connector on the SWM power inserter to the “Satellite In” jack on the receiver (see Figure 24).

Connecting Up to 8 SWM Receivers (13 Tuners Max)

- Connect an RF cable from the “Signal to IRD” connector on the SWM power inserter to the “SWM” input on an 8-way SWM splitter (see Figure 25).
- Connect the SWM splitter’s outputs to the “Satellite In” jack on the receivers/DVRs (or “Network” jack when connecting a Genie client). You can connect up to 8 SWM devices that add up to 13 or fewer tuners. Refer to Figure 25 to determine the tuners consumed by each type of device.

NOTE: HR34 and HR44 Genies both reserve 5 tuners. The HR54 Genie reserves 7 tuners.

- Terminate any unused outputs on the splitter with 75Ω terminators and tighten with a 7/16" torque wrench set to 20 in.-lbs.

Figure 24: Wiring 1 DIRECTV Receiver

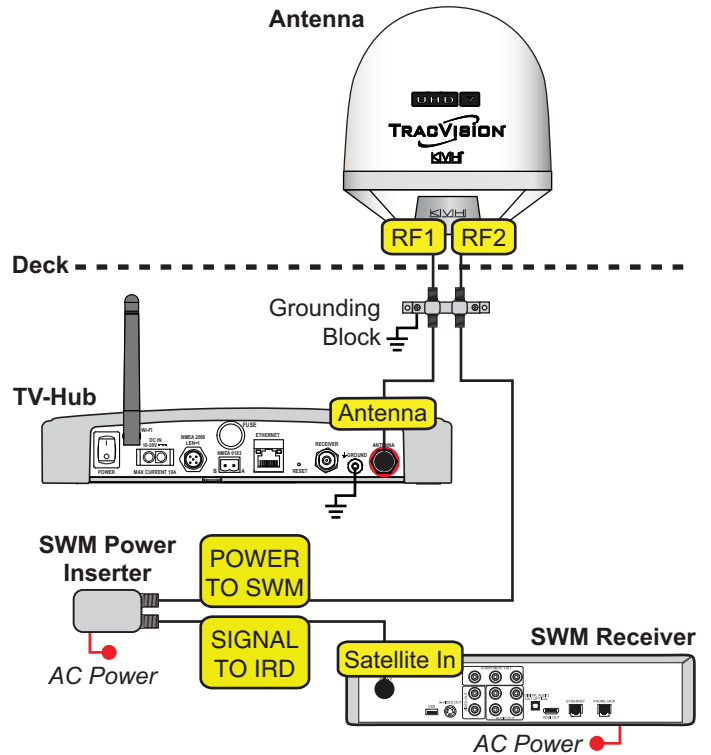
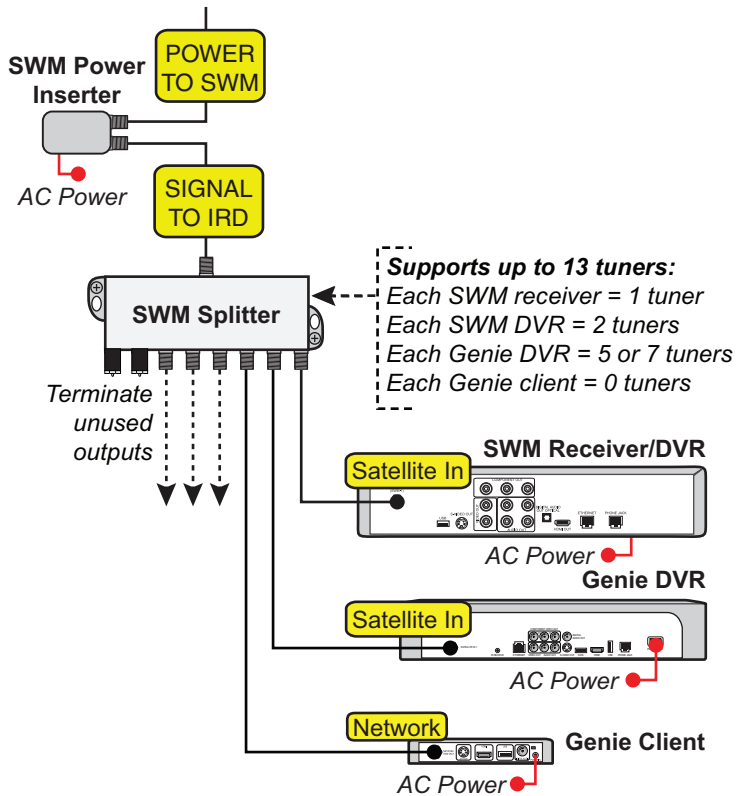

Figure 25: Wiring Up to 8 DIRECTV Receivers



Note: Connect any combination of receivers, DVRs, and Genie clients that add up to 13 or fewer tuners on the RF2 cable. Only 3 Genie clients can be active at one time.

12 Continued Wire the Receivers

Connecting 9 -13 SWM Receivers (13 Tuners Max)

- Connect an RF cable from the "Signal to IRD" connector on the SWM power inserter to the "SWM" input on a 2-way SWM splitter (see Figure 26).

IMPORTANT!

When wiring the receivers, be sure to keep the number of splits to no more than two per path.

- Connect the 2-way SWM splitter's outputs to the "SWM" inputs on two 8-way SWM splitters.
- Connect the 8-way SWM splitter's outputs to the "Satellite In" jacks on the receivers/DVRs (or "Network" jack when connecting a Genie client). Connect any combination of SWM devices that add up to 13 or fewer tuners. Refer to Figure 26 to determine the tuners consumed by each type of device.

NOTE: HR34 and HR44 both reserve 5 tuners. The HR54 reserves 7 tuners.

- Terminate any unused outputs on the splitters with 75Ω terminators and tighten with a 7/16" torque wrench set to 20 in.-lbs.

Figure 26: Wiring Up to 13 DIRECTV Receivers

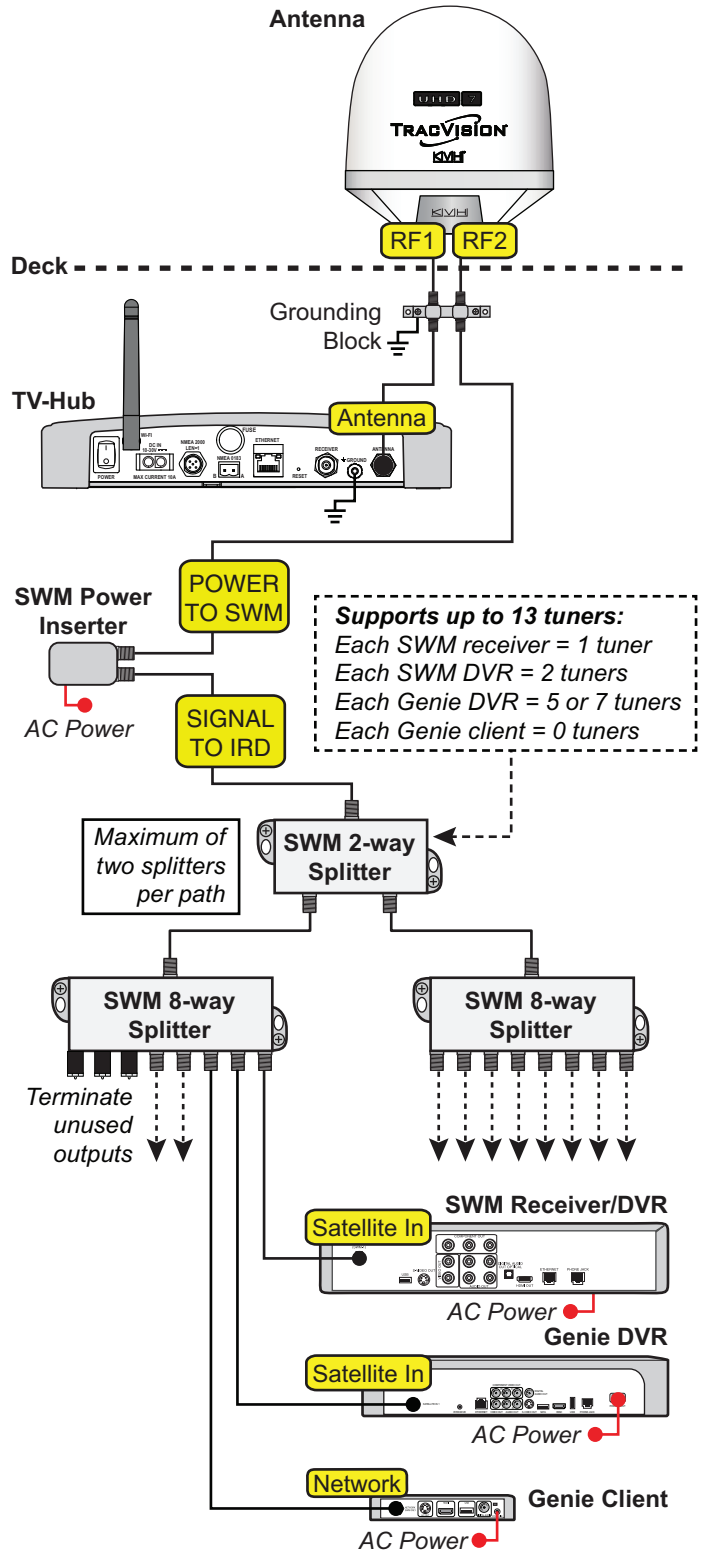

Note: Connect any combination of receivers, DVRs, and Genie clients that add up to 13 or fewer tuners on the RF2 cable. Only 3 Genie clients can be active at one time.

12 Continued Wire the Receivers

Connecting 14-26 Receivers (26 Tuners Max)

- a. First connect up to 13 receivers to the antenna's RF2 cable, as explained in "Connecting 9-13 SWM Receivers (13 Tuners Max)" on page 17).

IMPORTANT!
When wiring the receivers, be sure to keep the number of splits to no more than two per path.

NOTE: Only use DIRECTV-approved SWM splitters. Additional 2-way (KVH part no. 19-1016), 4-way (19-1017), and 8-way (19-0618) SWM splitters are available.

- b. Connect the RF3 cable to any combination of 2-, 4-, and/or 8-way SWM splitters, as necessary. Do not exceed two splitters per path.
- c. Connect the SWM splitter's outputs to the "Satellite In" jacks on the receivers/DVRs (or "Network" jack when connecting a Genie client). You can connect any combination of SWM devices that add up to 13 or fewer tuners on RF2 and up to 13 or fewer tuners on RF3 (26 total). Refer to Figure 27 to determine the tuners consumed by each type of device.
- d. Terminate any unused outputs on the splitters with 75Ω terminators and tighten with a 7/16" torque wrench set to 20 in.-lbs.

Figure 27: Wiring Up to 26 DIRECTV Receivers

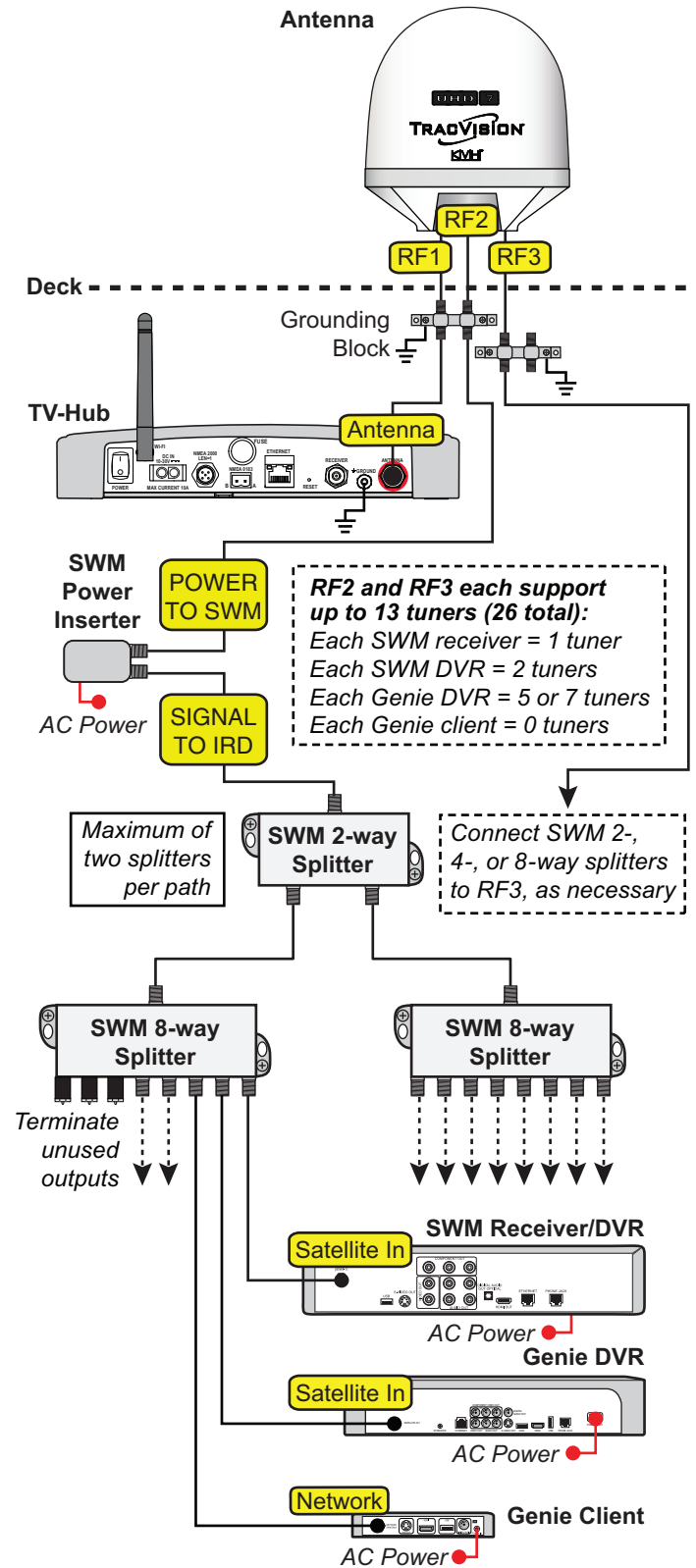

Note: Connect any combination of receivers, DVRs, and Genie clients that add up to 13 or fewer tuners on each RF cable (RF2 and RF3). Only 3 Genie clients can be active at one time.

12 Continued Wire the Receivers

DISH Network and Bell TV Wiring

Follow these steps to connect most DISH Network (non-Wally) or Bell TV receivers to the TracVision system. (To connect Wally receivers, refer to “Using Wally Receivers” on page 32.)

IMPORTANT!



Receivers must be DISH Pro-compatible. Look for the DISH Pro logo on the box.

IMPORTANT!

You **must** connect the SWM power inserter to the antenna’s RF2 cable for all DISH/Bell configurations. The SWM power inserter supplies power to the antenna’s LNB.

Connecting 1 Receiver

Connect an RF cable from the “Receiver” jack on the TV-Hub to the “Satellite In” jack on the receiver (see Figure 28).

Connecting 2 Receivers

- Connect an RF cable from the “Receiver” jack on the TV-Hub to the “Antenna” jack on the DC block splitter (supplied in kit).
- Connect the “Primary” jack on the DC block splitter to the “Satellite In” jack on the first receiver.
- Connect the “Secondary” jack on the splitter to the “Satellite In” jack on the second receiver (see Figure 29).

Connecting 3 or More Receivers

- Connect an RF cable from the TV-Hub to the DC block splitter and connect the DC block splitter to the first receiver, as explained in “Connecting 2 Receivers” on page 19.
- Connect the “Secondary” jack on the splitter to the “18V” port on a multiswitch (see Figure 30). KVH offers a 4-output passive multiswitch (KVH part no. 72-0676) and an 8-output active multiswitch (KVH part no. 72-0310).
- Connect the multiswitch outputs to the “Satellite In” jacks on the additional receivers.

Figure 28: Wiring 1 DISH/Bell Receiver

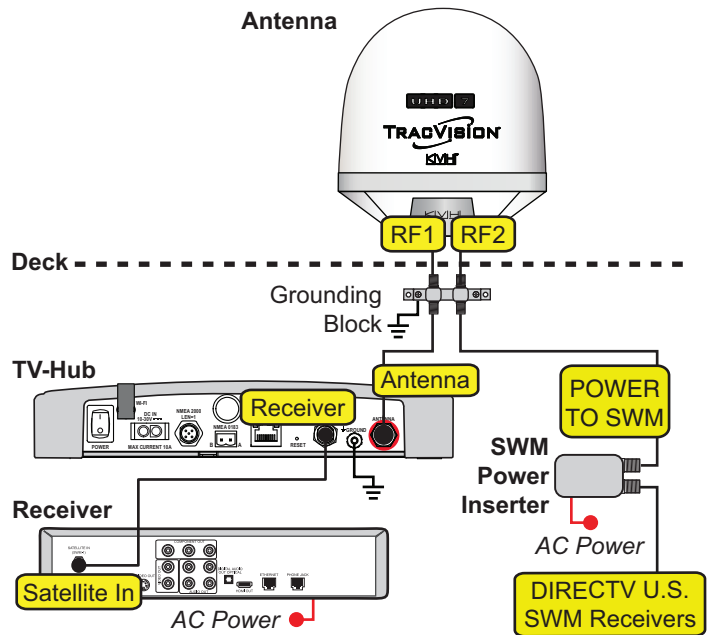

Figure 29: Wiring 2 DISH/Bell Receivers

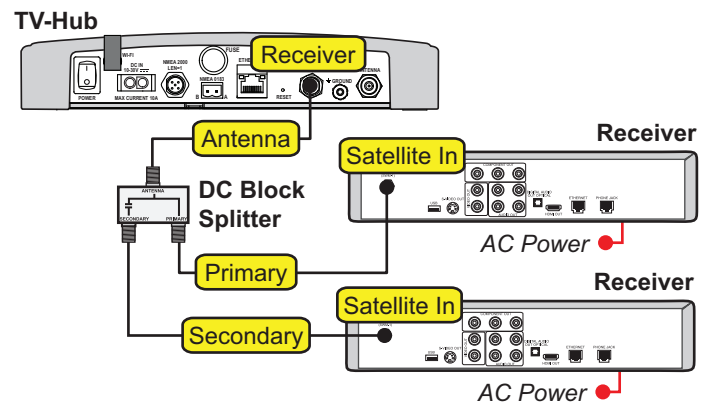
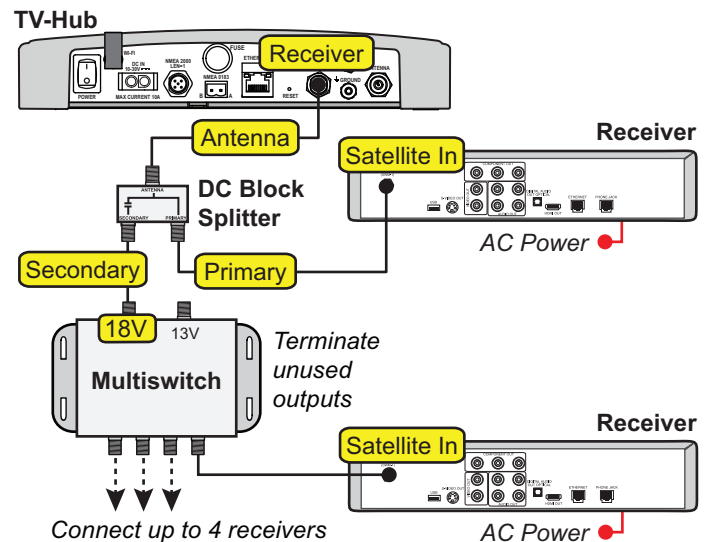

Figure 30: Wiring 3+ DISH/Bell Receivers



13 Connect a NMEA Device

Optional

At the customer's option, you can connect a NMEA device to the TV-Hub, allowing the antenna to use its GNSS heading data to speed up satellite acquisition. A NMEA device will also provide position data as a backup to the antenna's built-in GPS. The current heading will also be displayed on the Home page of the web interface.

NOTE: The antenna system can only use and display true heading. If only magnetic heading is input, the TV-Hub will use the current location data to convert magnetic heading to true heading.

Follow these steps to connect a NMEA device to the TV-Hub, if desired.

NMEA 0183

- Wire and connect the 2-position terminal strip connector (supplied in kit) as shown in Figure 31.
- Configure the NMEA device to transmit one or more of the supported NMEA 0183 messages at 4800 baud (see Figure 32).
- Make sure the data message(s) includes the checksum, identifiable by a *xx field at the end of the data sentence (e.g., \$HEHDT,123.4, T*1F). Do not exceed a 10 Hz input rate.

NMEA 2000

- Connect the TV-Hub to the vessel's NMEA 2000 CAN network backbone via a "T" connector, as shown in Figure 31. Be sure to use a standard drop cable: 5-wire (4 conductors + shield) twisted pair with micro-C connectors.
- Configure the NMEA device to transmit one or more of the supported NMEA 2000 messages (see Figure 33).

Later, you will select the NMEA source at the TracVision Setup Wizard (see "Setup Wizard" on page 28).

Figure 31: TV-Hub NMEA Connections

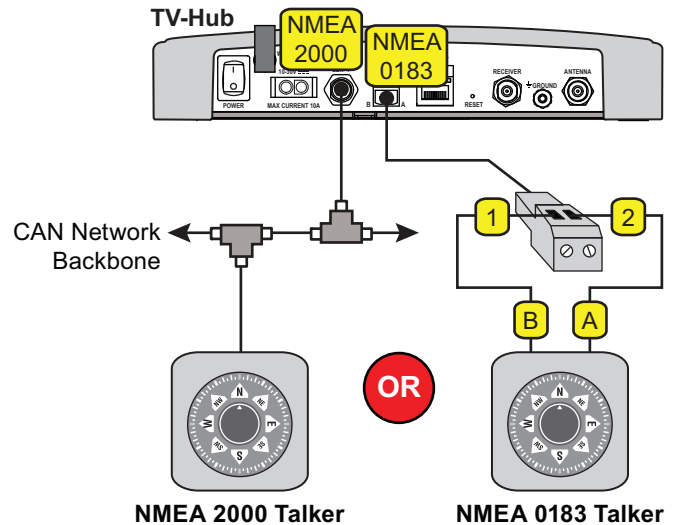

Figure 32: Supported NMEA 0183 Messages

NMEA 0183 \$--xxx	Description
HDG	Heading, Deviation & Variation
HDM	Heading, Magnetic
HDT	Heading, True
OSD	Own Ship Data
THS	True Heading & Status
VHW	Water Speed and Heading
RMC	GNSS Position Data

Figure 33: Supported NMEA 2000 Messages

PGN	Description
127250	Vessel Heading
129029	GNSS Position Data

14 Connect Power

Before connecting power, be sure the vessel is properly grounded in accordance with marine standards.

Grounding Requirements

Proper grounding of the TracVision system to ship's ground is mandatory for electromagnetic compatibility (EMC) and safety regulatory compliance. It protects the equipment from electrostatic discharges (ESD) and prevents interference with other electronic equipment. Follow these steps to ground the system.

IMPORTANT!

The TV-Hub and any grounding blocks must be connected to the ship's common ground to maintain the same electrical ground potential.

- Connect the hoop of the grounding wire (supplied in kit) to the "Ground" screw on the rear panel of the TV-Hub. Connect the other end to ship's common ground.
- Connect grounding blocks in-line with all of the RF cables. Attach a ground wire from each grounding block to ship's ground. Then mount each grounding block using the two supplied #6 screws (see Figure 34).



WARNING

Failure to ground the TracVision system properly to the vessel's ground will cause an unsafe floating ground condition, risking damage to the antenna and electric shock, potentially resulting in DEATH. In a floating ground condition, the difference between the equipment's chassis ground and the vessel's ground can measure well over 100 volts, when it normally should not exceed 2 volts. Therefore, always measure the difference in potential between chassis ground and the vessel's ground to make certain there is no dangerous floating ground condition.

Figure 34: Grounding Block Example

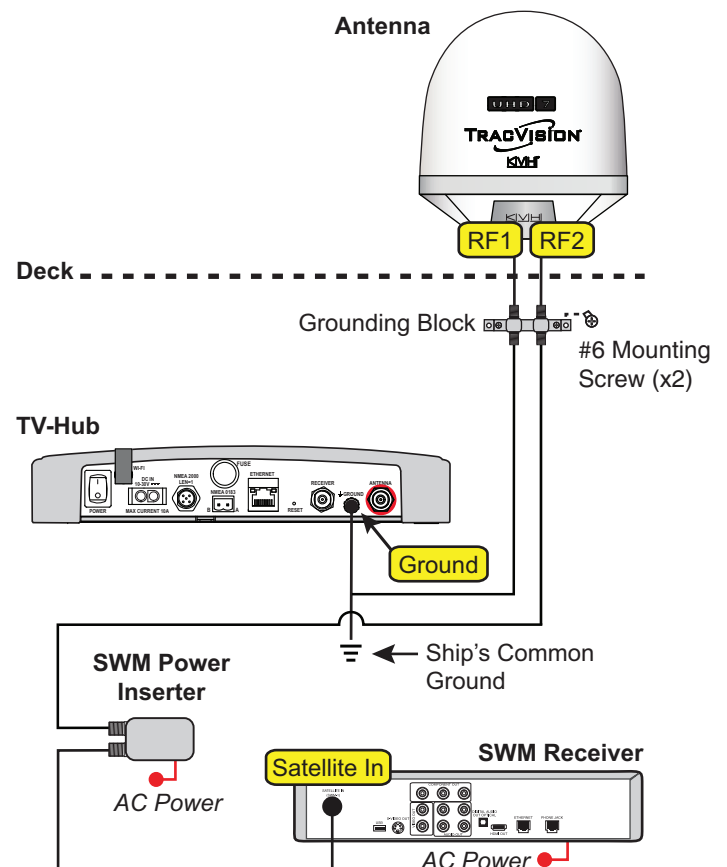

14 Continued Connect Power

Connect Power to the System

NOTE: Apply power to all other system components before powering up the receivers and DVRs (tuners are assigned SWM channels during startup).

Follow these steps to connect power to the TracVision system, but do **not** power it on.

IMPORTANT!

All power connections must be hard wired.

- Make sure the TV-Hub's ground wire has been connected as described on the previous page.
- Connect the TV-Hub power cable (supplied in kit) to the 10-30 VDC power input on the rear of the TV-Hub.
- Connect the black wire of the TV-Hub power cable to DC return (ship's ground), and the red wire to the vessel's DC power supply (see Figure 35).
- Connect the SWM power inserter's power cable to an AC power supply.

NOTE: The TV-Hub requires 10-30 VDC from an appropriate DC power source. An optional 24 VDC AC-DC power supply (5 A, 120 W) is available from KVH (part no. 72-0669). The SWM power inserter requires 120 VAC. DC-AC power inverters are available from third party suppliers, if required.

- Check for proper grounding by using a multimeter to measure the AC and DC voltages between the ground stud on the rear of the TV-Hub and ship's ground. The measured voltage should be less than 2 VAC and 2 VDC.
- Repeat step e with the TV-Hub powered on, looking for the same measured result (see "Turn On the System" on page 23).



WARNING

If you measure 2 volts or greater, notify the ship's electrician or authorized vessel representative immediately. This is a dangerous condition. Do not touch the TV-Hub rear panel or connect anything to it until the problem is fixed.

Figure 35: TracVision System Power

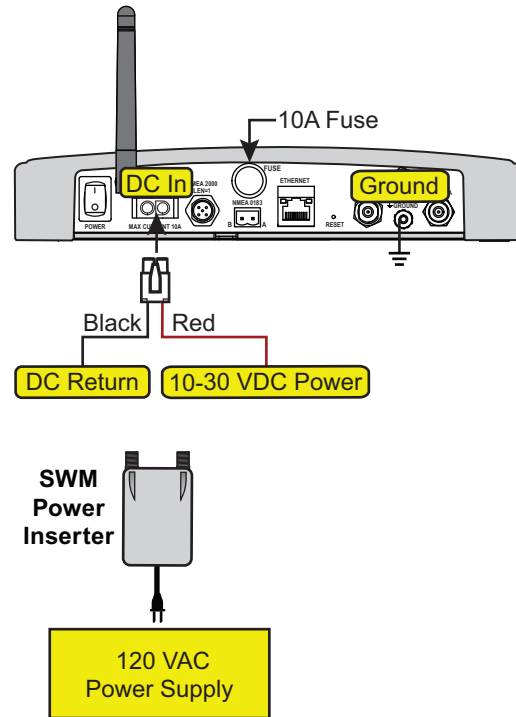

15 Turn On the System

Follow these steps to turn on the system for the first time.

- a. Ensure the antenna has a clear, unobstructed view of the sky.
- b. Press the power switch on the rear panel of the TV-Hub to apply power to the TracVision system (see Figure 36).

IMPORTANT!

During startup, the TV-Hub checks the software versions installed in the antenna and updates them if necessary to match the versions it has stored for that model. All three status lights (see Figure 37) will alternate orange while this update is in progress. **Do not turn off the system during this time.** Updates might take up to 40 minutes.

- c. Within a few minutes, the TV-Hub and Power lights should be lit green (the Antenna light will flash green until the antenna finds a satellite).
- d. Plug in and turn on any connected receivers, DVRs, Genie clients, and televisions.

Figure 36: TV-Hub Power Switch

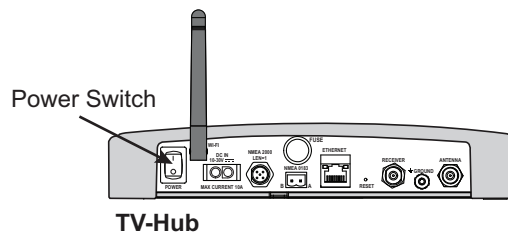
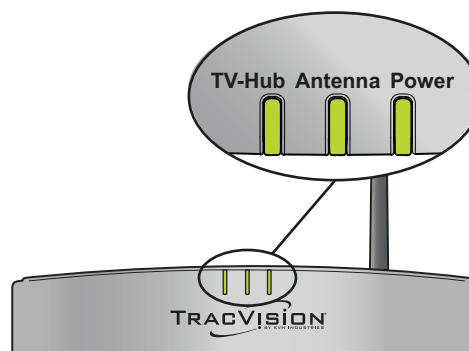

Figure 37: TV-Hub Status Lights



16 Access the Web Interface

Follow the steps for either option below to access the TV-Hub's web interface.

Option 1: Using the Wireless Connection

- a. Select the TVHub-<TV-Hub serial number> network from your device's Wi-Fi settings to connect to the TV-Hub (see Figure 38).
- b. Start your web browser and enter **http://tvhub.kvh**. If the web interface does not appear, try entering **http://172.16.0.1**, which is the default IP address of the TV-Hub.

Option 2: Using the Ethernet Connection

- a. Connect a laptop PC configured for DHCP directly to the "Ethernet" port on the TV-Hub (see Figure 39).
- b. Start your web browser and enter **http://169.254.253.1**.

NOTE: When connected to a vessel's LAN (see "Connect to an Onboard Network" on page 25), you will need to enter the IP address (dynamic or static) assigned to the TV-Hub. If your laptop has Bonjour[®] installed, you can use it to find the TV-Hub on the network without knowing its IP address.

Figure 38: Wi-Fi Connection

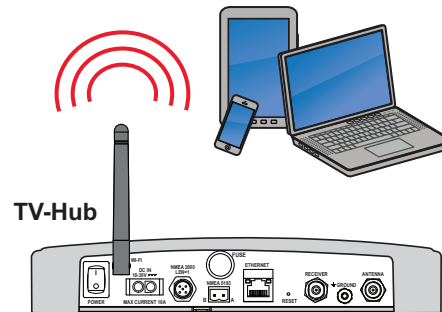
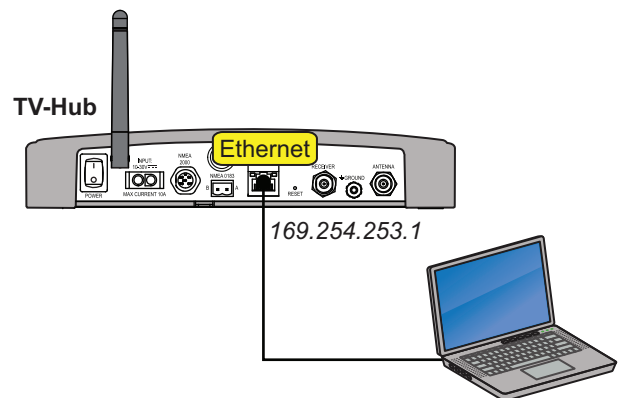

Figure 39: Wired Ethernet Connection



17 Connect to an Onboard Network

Optional

Connecting the TV-Hub to an onboard local area network (LAN) allows the user to access the TV-Hub's web interface using any device connected to the network (see Figure 40).

NOTE: Connecting the TV-Hub to the onboard network using its Wi-Fi rather than an Ethernet cable is not recommended because you lose the ability to connect directly to the TV-Hub's built-in Wi-Fi. You will always need to connect via the network.

NOTE: The Reset button on the rear panel of the TV-Hub (see Figure 41) reverts all network settings back to their original factory settings.

Wired LAN Connection

NOTE: Before connecting via wired LAN, KVH recommends that you set the TV-Hub to **Static** mode and assign a static IP address (see Figure 42). Be sure to choose a static IP address that is outside the router's DHCP range (refer to the router's manual).

- To assign a static IP address, first connect your laptop or mobile device to the TV-Hub (see "[Access the Web Interface](#)" on page 24).
- At the web interface, go to **Settings > Network Settings**. Set the TV-Hub to a static IP address on the onboard network.
- Connect the "Ethernet" port on the TV-Hub to the onboard network (LAN) using the supplied Ethernet cable.

Figure 40: TV-Hub Network Connections

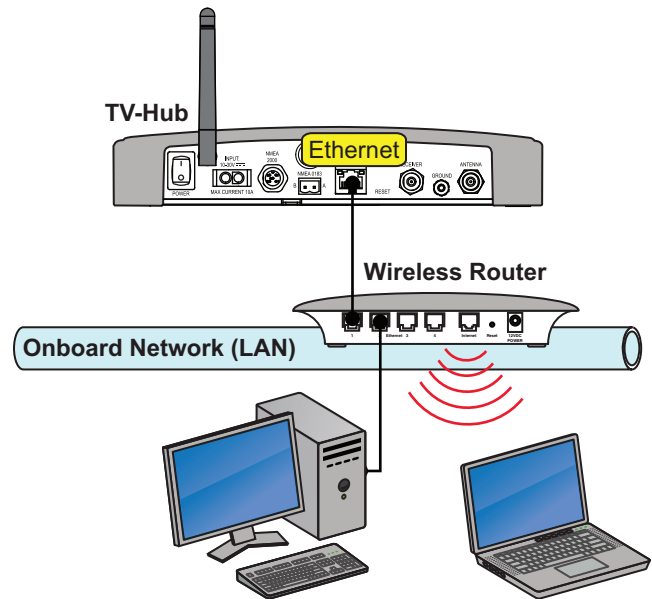

Figure 41: TV-Hub Reset Button

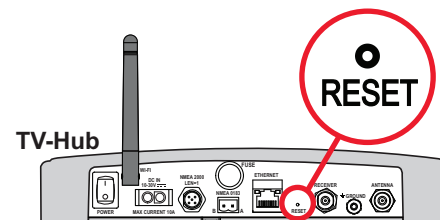

Figure 42: Web Interface Ethernet Settings

Ethernet Settings	
Mode	STATIC
IP Address	172.16.223.92
Subnet	255.255.255.0
Gateway	172.16.223.1
Broadcast	172.16.223.255

18 Secure the Wi-Fi Connection

Connect the “Ethernet” port on the TV-Hub to the onboard network (LAN) using the supplied Ethernet cable. By default, the TV-Hub’s wireless settings are configured for the following:

- Wireless Mode: AP (Access Point)
- SSID: TV-Hub-<TV-Hub serial number>
- IP Address: 172.16.0.1
- Security Mode: Off

KVH requires that you select the **WPA_PSK** security mode as shown in Figure 43 and assign a unique password to prevent unauthorized access to the TV-Hub (at the web interface, go to Settings > Network Settings). If you keep the default settings, you’re allowing anyone to access the TV-Hub with their mobile device.

IMPORTANT!

KVH strongly recommends that you keep the TV-Hub set to AP (Access Point) wireless mode. If you select IF (Infrastructure) mode to connect the TV-Hub to your onboard network, you will no longer be able to access the TV-Hub’s web interface directly.

Figure 43: TV-Hub Security and Password Setting

Wireless Settings	
Wireless Mode	AP (Access Point) ▾
SSID	TVHub-140311659
IP Address	172.16.0.1
Subnet	255.255.255.0
Gateway	172.16.0.1
Broadcast	172.16.0.1
Security Mode	WPA_PSK ▾
Password	240300659

19 Set Up the System

The Setup Wizard appears upon initial startup to step you through system configuration (see Figure 44). Before you begin to set up the system:

- Know the service provider and associated satellite(s)
- Check the latest software version (see below)
- Verify all system components are connected

Update Software and Satellite Library

Before you start the Setup Wizard, update the system software and satellite library to the latest versions. Use the Apple® iOS or Android™ smartphone/tablet mobile app, or follow these steps to use a laptop PC that has the latest update files downloaded to it from the KVH Partner Portal (www.kvh.com/partners).

- Select **Exit** in the Setup Wizard page. The web interface appears.
- At the Updates page of the web interface, select the antenna model. Then select **Install Update** (see Figure 45). Find the **.kvh** file in your downloads folder, then double-click to install.
- Wait for the update to complete. It may take up to 45 minutes. The TV-Hub's lights will alternate orange while the update is in progress. Once complete, the web interface will report that the latest version is installed.
- When the software update is complete, select the Satellite Library. Then select **Install Update**. Find the **.xml** file in your downloads folder, then double-click to install.
- Navigate to **Settings > General Settings** and launch the Setup Wizard.
- Select **Proceed with Setup Wizard**.

Figure 44: Setup Wizard Welcome Page

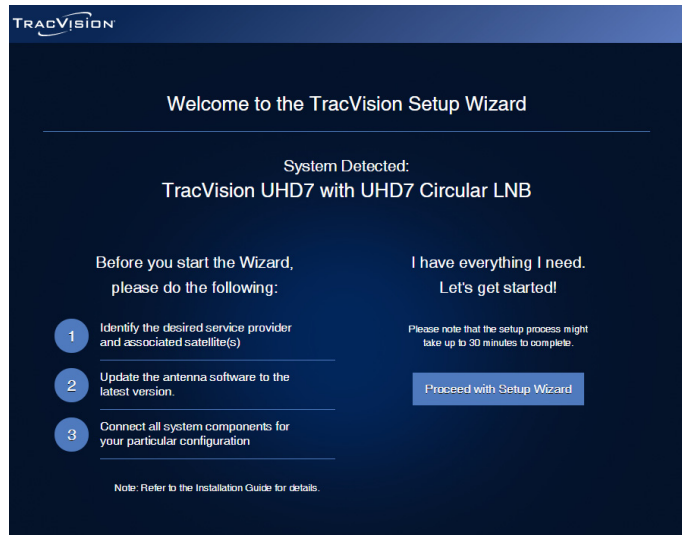

Figure 45: Software Updates Page



19 Continued Set Up the System

Setup Wizard

System configuration continues by prompting you to enter information or perform certain tasks, as necessary. For example:

- Enter installer and vessel information
- Select a backup source for GNSS position data, if desired
- Select a backup source for heading data (if NMEA device is connected)
- Select the satellite TV service
- Select a satellite to track; default is DIRECTV TRI-SAT, but you can make your own selections from the satellite library (see Figure 46)
- Run a Check Switch test for DISH Network/Bell TV receivers (see [“Run a Check Switch Test” on page 30](#) for most receivers and [“Running a Check Switch Test on Wally Receivers” on page 37](#) for Wally receivers)

Additional Setup Information

Once the Setup Wizard has been completed, perform follow-up tasks such as:

- Set up receivers to operate with the system (as instructed by the Wizard)
- Activate the receivers (as instructed by the Wizard)

Figure 46: Satellite Library



Select	Name	Orbital Slot	Region	Favorites
<input type="radio"/>	Bell TV HD	82W	North America	♥
<input type="radio"/>	DIRECTV LA	95W	Central/South America	♥
<input type="radio"/>	Anik F3	118W	North America	♥
<input type="radio"/>	Nimiq 5	72W	North America	♥
<input type="radio"/>	Bonum 1	56E	Asia	♥
<input type="radio"/>	DIRECTV 11	99W	North America	♥
<input type="radio"/>	EchoStar 1 - Mexico	77W	Central/South America	♥
<input checked="" type="radio"/>	DIRECTV TRI-SAT	101W	North America	♥
<input type="radio"/>	User Circular 1	N/A	N/A	♥
<input type="radio"/>	User Circular 2	N/A	N/A	♥

20 Configure SWM Receivers/DVRs

Follow these steps to set or verify the dish type or configuration of each SWM receiver and/or DVR connected to the TracVision system.

NOTE: Refer to your selected receiver/DVR manual for specific configuration instructions.

- a. Press the Menu button on the receiver's/ DVR's remote control to display its menu on the connected television.
- b. Navigate to the Satellite screen (Settings > Settings & Help > Satellite) and select **Repeat Satellite Setup**.
- c. At the Satellite Dish Setup menu, set the Dish Type and RB/INTL to the settings below. Switch Type should auto-populate:
Dish Type: **SL3 LNB**.
RD/INTL: **None Selected**
Switch Type: **SWM Module 15 CH**
- d. Make any necessary changes, then choose **Continue** to complete setup (see Figure 47).
- e. Repeat this procedure for each connected receiver and DVR.

Figure 47: DIRECTV SWM Receiver/DVR Configuration

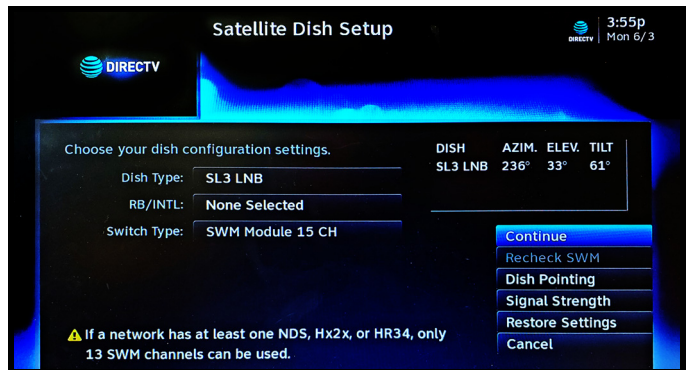

21

Run a Check Switch Test

Follow these steps to run a Check Switch test of each DISH Network/Bell TV receiver and/or DVR connected to the TracVision system. (To run a Check Switch test on Wally receivers, refer to "Running a Check Switch Test on Wally Receivers" on page 37.)

- a. Ensure the antenna is tracking a DISH Network (e.g., 77W) or Bell TV (e.g., 91W) satellite, as applicable.

IMPORTANT!

To run a Check Switch test on any DISH/Bell receiver other than a Wally, you will need to temporarily connect each DISH/Bell receiver, one at a time, directly to the "Receiver" port on the TV-Hub. Refer to the Help for more details.

- b. Connect each receiver directly to the "Receiver" port on the back of the TV-Hub.
- c. Navigate to the Point Dish/Signal Screen by pressing **MENU, 6, 1, 1** on your remote control.
- d. Choose Check Switch, then press **SELECT**.
- e. Choose Check (Bell TV) or Test (DISH Network), then press **SELECT**.
- f. Wait up to 10 minutes for the test to complete and the receiver's Program Guide to load. Once complete, the Check Switch test displays the current satellite, switch type "DP34", and OK (see Figure 48).
- g. Return the receiver to its proper location.

DISH Network/Bell TV Only

Figure 48: DISH Network/Bell TV receiver/DVR Check Switch Screen

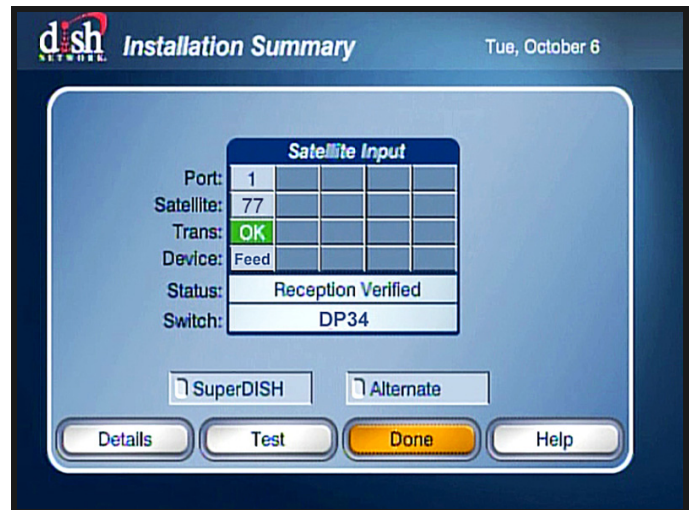

22 Educate the Customer

Before you leave the vessel, test the system to ensure the antenna works properly. Fill out the Installation Checklist (provided in the Welcome Kit) and return it to KVH. Refer to the instructions on the form.

Give the Welcome Kit to the customer, provide any passwords and static IP addresses you set up, and explain how to use the system. Ensure the customer understands the following.

- How to:
 - Turn on the system
 - Access the web interface
 - Interpret TV-Hub status information
 - Download software and satellite library updates (using web interface and/or mobile app)
 - Perform general troubleshooting
- Keep the radome installed on the antenna at all times. The radome protects the antenna's moving parts from wind, rain, and debris.



CAUTION

In the unlikely event that you need to remove the radome, remove power from the antenna first because the antenna's moving parts can cause injury.

- The antenna must have a clear view of the sky to receive satellite TV. Common causes of blockage include trees, buildings, bridges, and onboard equipment (see Figure 49). Heavy rain or snow might also temporarily interrupt reception.
- Clean the antenna regularly. Dirt buildup on the radome can affect satellite TV reception.
- You must be located within the satellites' coverage area to receive TV signals. Visit www.kvh.com/footprint for coverage maps.
- Please register the system to ensure the best possible service from KVH. Visit www.kvh.com/register for details.

Figure 49: Blockage Example

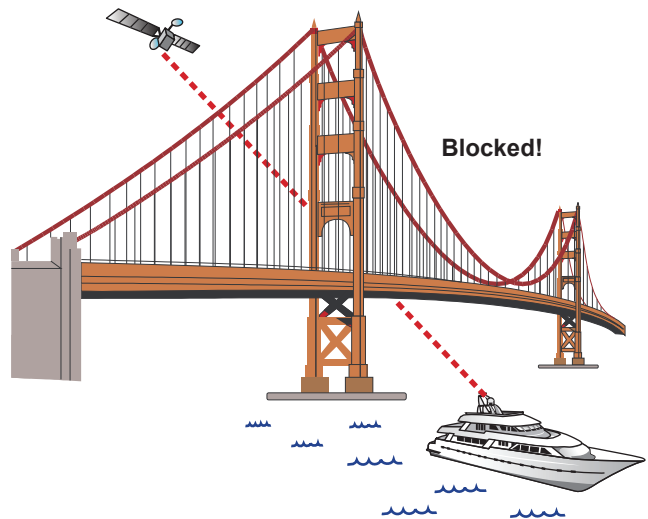

A Using Wally Receivers

Appendix

Wiring DISH Network Wally receivers requires additional equipment and modified wiring configurations, as explained below.

Wiring Wally Receivers

To wire Wally receivers, you need to install a DISH Pro hybrid switch (model DPH42) (KVH part no. 19-1122) in-line between the TV-Hub and the receivers. To connect more than two Wally receivers (up to a maximum of 32) to the DPH42, you also need one or more 2-way (19-1120) or 4-way (19-1121) channel stack splitters.

NOTE: Additional 2-way and 4-way channel stack splitters are available from KVH.

Follow the steps below and on the preceding pages to connect Wally receivers to the TracVision system.

IMPORTANT!

You must connect the SWM power inserter to the antenna's RF2 cable for all DISH configurations. The SWM power inserter supplies power to the antenna's LNB.

Connecting 1 or 2 Wally Receivers

- Connect an RF cable from the "Receiver" jack on the TV-Hub to the first "To Dish" jack on a DPH42.
- Connect the first "Receiver Satellite In" jack on the DPH42 to the "To Switch Input" jack on the power inserter (supplied with the DPH42).

NOTE: The SWM power inserter requires 120 VAC. DC-AC power inverters are available from third party suppliers, if required.

- Connect the "To Receiver Satellite In" jack on the power inserter to the "Satellite In" jack on the receiver.
- If desired, connect the second "Receiver Satellite In" jack on the DPH42 to the "Satellite In" jack on the second receiver (see Figure 28).

Figure 50: Wiring 1 or 2 DISH Wally Receiver

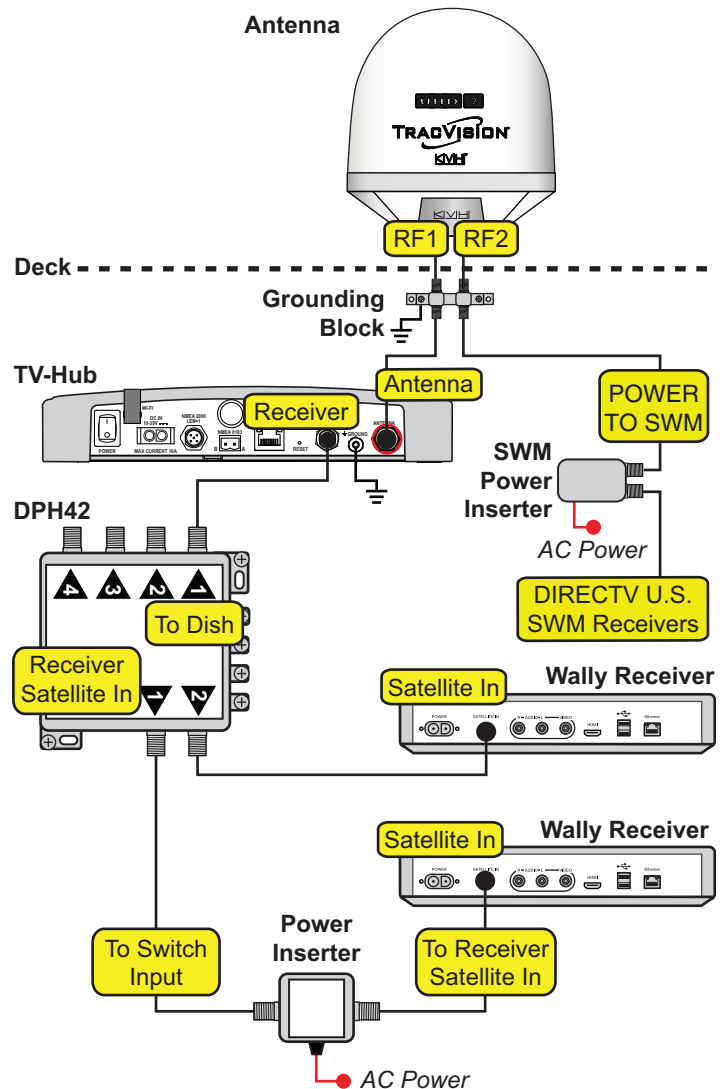

A

Continued Using Wally Receivers

Appendix

Connecting Up to 5 Wally Receivers

- Connect an RF cable from the "Receiver" jack on the TV-Hub to the first "To Dish" jack on the DPH42.
- Connect the first "Receiver Satellite In" jack on the DPH42 to the "To Switch Input" jack on the power inserter (supplied with the DPH42).

NOTE: The SWM power inserter requires 120 VAC. DC-AC power inverters are available from third party suppliers, if required.

- Connect the "To Receiver Satellite In" jack on the power inserter to the "In" jack on a 2-way or 4-way channel stack splitter.
- Connect the channel stack splitter's outputs to the "Satellite In" jacks on four receivers.
- Connect the second "Receiver Satellite In" jack on the DPH42 to the "Satellite In" jack on a fifth receiver (see Figure 51).

Figure 51: Wiring Up to 5 Wally Receivers

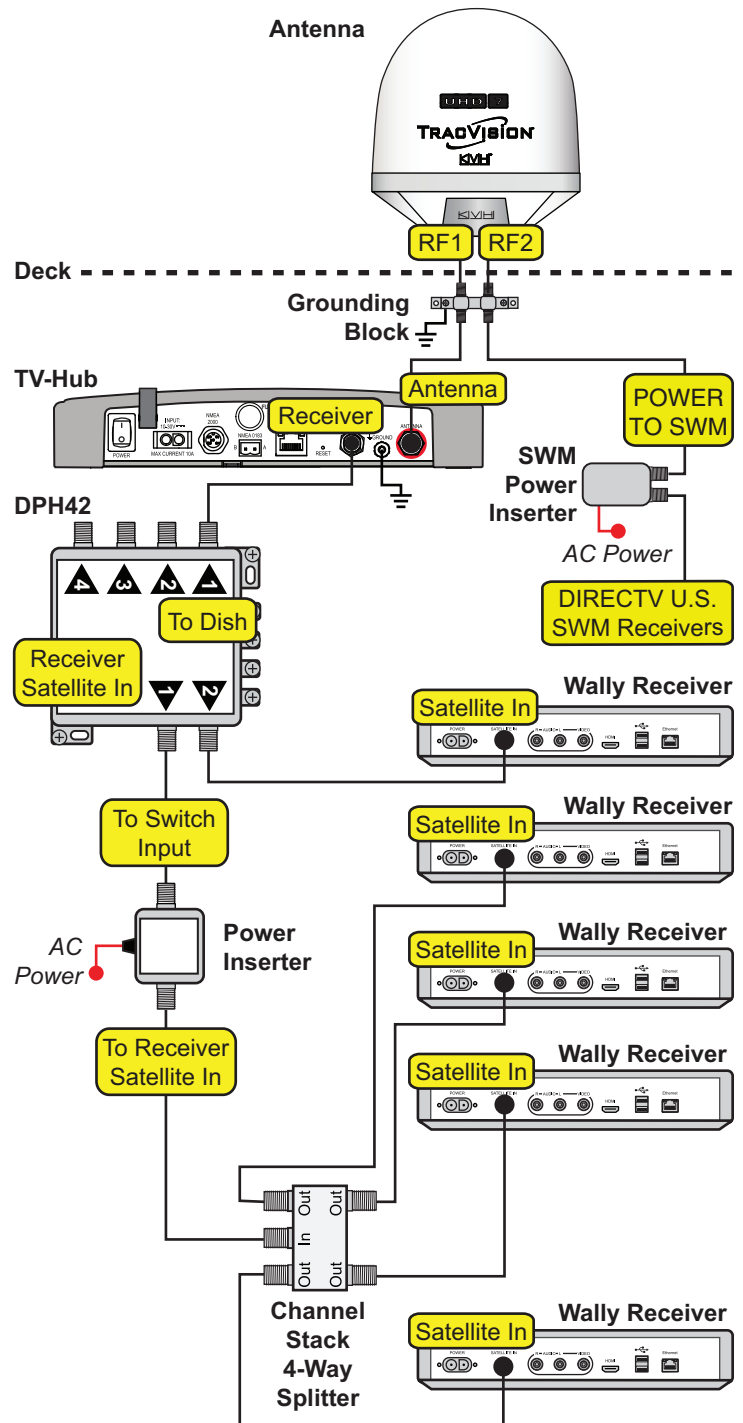

A

Continued Using Wally Receivers

Appendix

Connecting Up to 16 Wally Receivers

- Connect an RF cable from the "Receiver" jack on the TV-Hub to the first "To Dish" jack on the DPH42.
- Connect the first "Receiver Satellite In" jack on the DPH42 to the "To Switch Input" jack on the power inserter (supplied with the DPH42).

NOTE: The SWM power inserter requires 120 VAC. DC-AC power inverters are available from third party suppliers, if required.

- Connect the "To Receiver Satellite In" jack on the power inserter to the "In" jack on a 2-way or 4-way channel stack splitter.
- Connect the channel stack splitter's outputs to any combination of 2-way and 4-way channel stack splitters, as necessary.
- Connect the outputs of all the splitters to the "Satellite In" jacks of up to a maximum of 16 Wally receivers (see Figure 52).

Figure 52: Wiring Up to 16 Wally Receivers

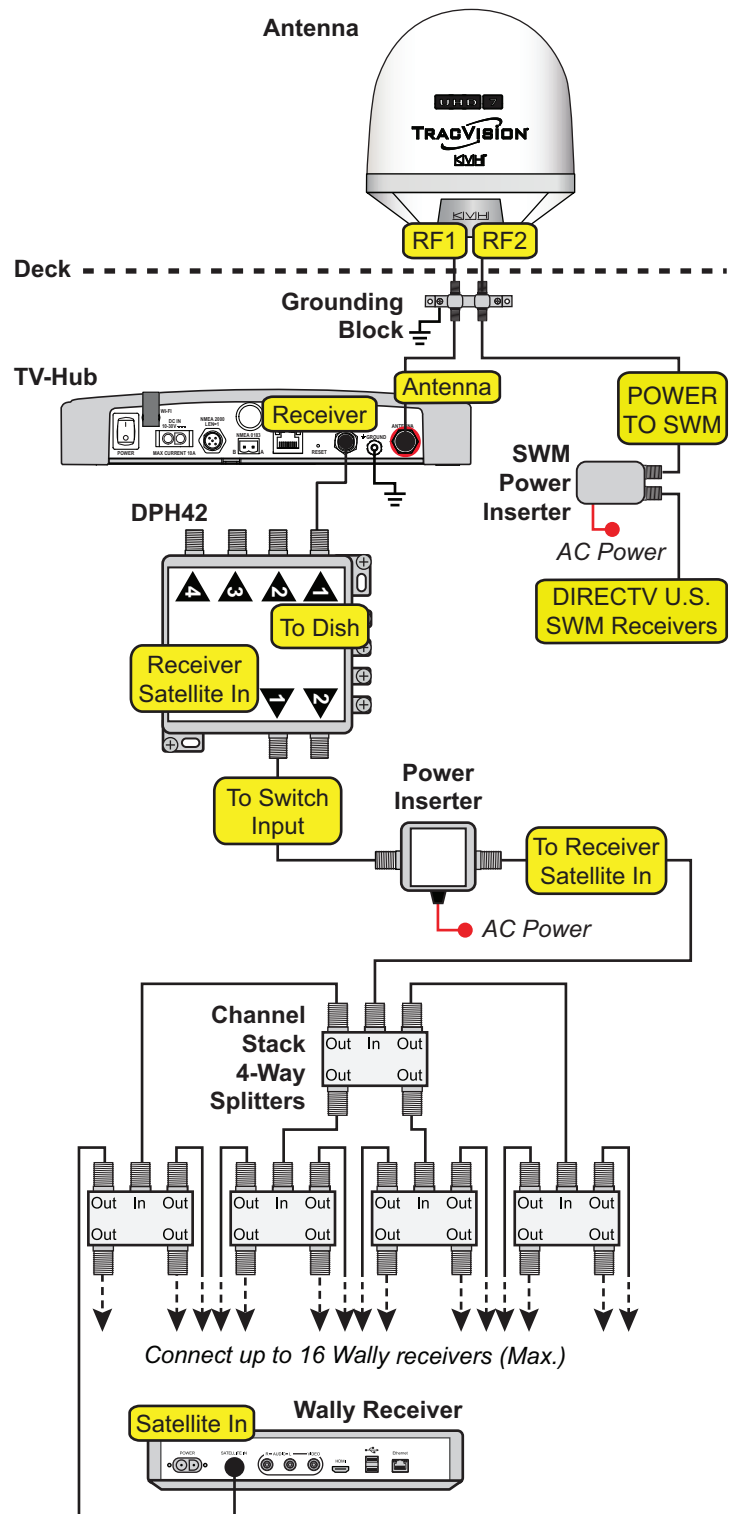

A

Continued Using Wally Receivers

Appendix

Connecting Up to 32 Wally Receivers

- Connect an RF cable from the "Receiver" jack on the TV-Hub to the first "To Dish" jack on the DPH42.
- Connect the first "Receiver Satellite In" jack on the DPH42 to the "To Switch Input" jack on the power inserter (supplied with the DPH42).

NOTE: The SWM power inserter requires 120 VAC. DC-AC power inverters are available from third party suppliers, if required.

- Connect the "To Receiver Satellite In" jack on the power inserter to the "In" jack on a 2-way or 4-way channel stack splitter.
- Connect the channel stack splitter's outputs to any combination of 2-way and 4-way channel stack splitters, as necessary.
- Connect the outputs of all the splitters to the "Satellite In" jacks of up to 16 Wally receivers.
- Connect up to 16 receivers at the second "Receiver Satellite In" jack, using any combination of 2-way and 4-way channel stack splitters, as necessary, to connect a maximum of 32 Wally receivers (see Figure 53).

Figure 53: Wiring Up to 32 Wally Receivers

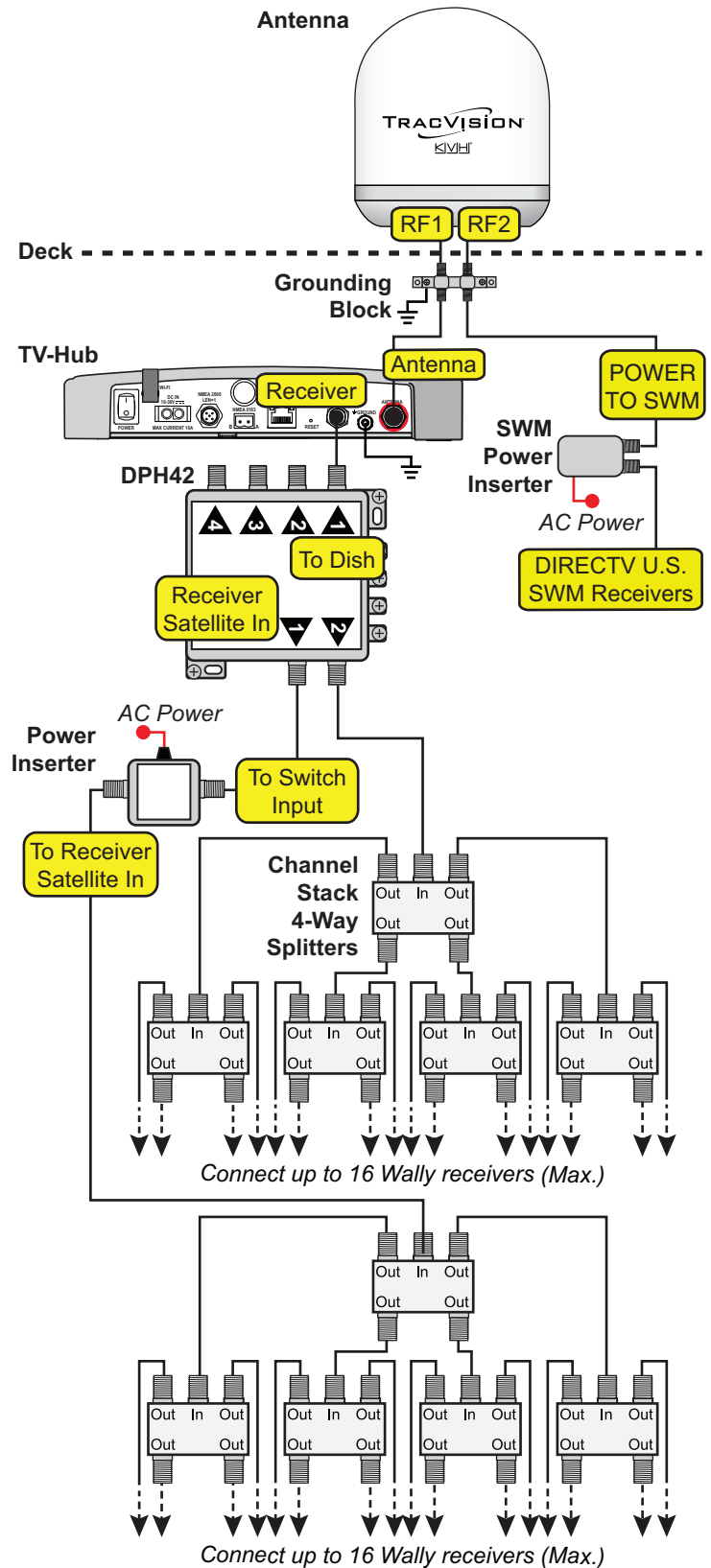

A

Continued Using Wally Receivers

Appendix

Connecting a Mix of Wally and Non-Wally Receivers

- Connect an RF cable from the "Receiver" jack on the TV-Hub to the "Antenna" jack on the DC block splitter (*supplied in kit*).
- Connect the "Primary" jack on the DC block splitter to the first "To Dish" jack on the DPH42.
- Connect the first "Receiver Satellite In" jack on the DPH42 to the "To Switch Input" jack on the power inserter (*supplied with the DPH42*).

NOTE: The SWM power inserter requires 120 VAC. DC-AC power inverters are available from third party suppliers, if required.

- Connect the "To Receiver Satellite In" jack on the power inserter to the "In" jack on a 2-way or 4-way channel stack splitter.
- Connect the channel stack splitter's outputs to any combination of 2-way and 4-way channel stack splitters, as necessary.
- Connect the outputs of all the channel stack splitters to the "Satellite In" jacks of up to 16 Wally receivers.
- Connect up to 16 receivers at the second "Receiver Satellite In" jack, using any combination of 2-way and 4-way channel stack splitters, as necessary, to connect a maximum of 32 Wally receivers.
- Connect the "Secondary" jack on the DC block splitter to the "18V" port on a multiswitch. KVH offers a 4-output passive multiswitch (KVH part no. 72-0676) and an 8-output active multiswitch (KVH part no. 72-0677).
- Connect the multiswitch outputs to the "Satellite In" jacks on non-Wally receivers (see Figure 54).

Figure 54: Wiring a Mix of Wally/Non-Wally Receivers

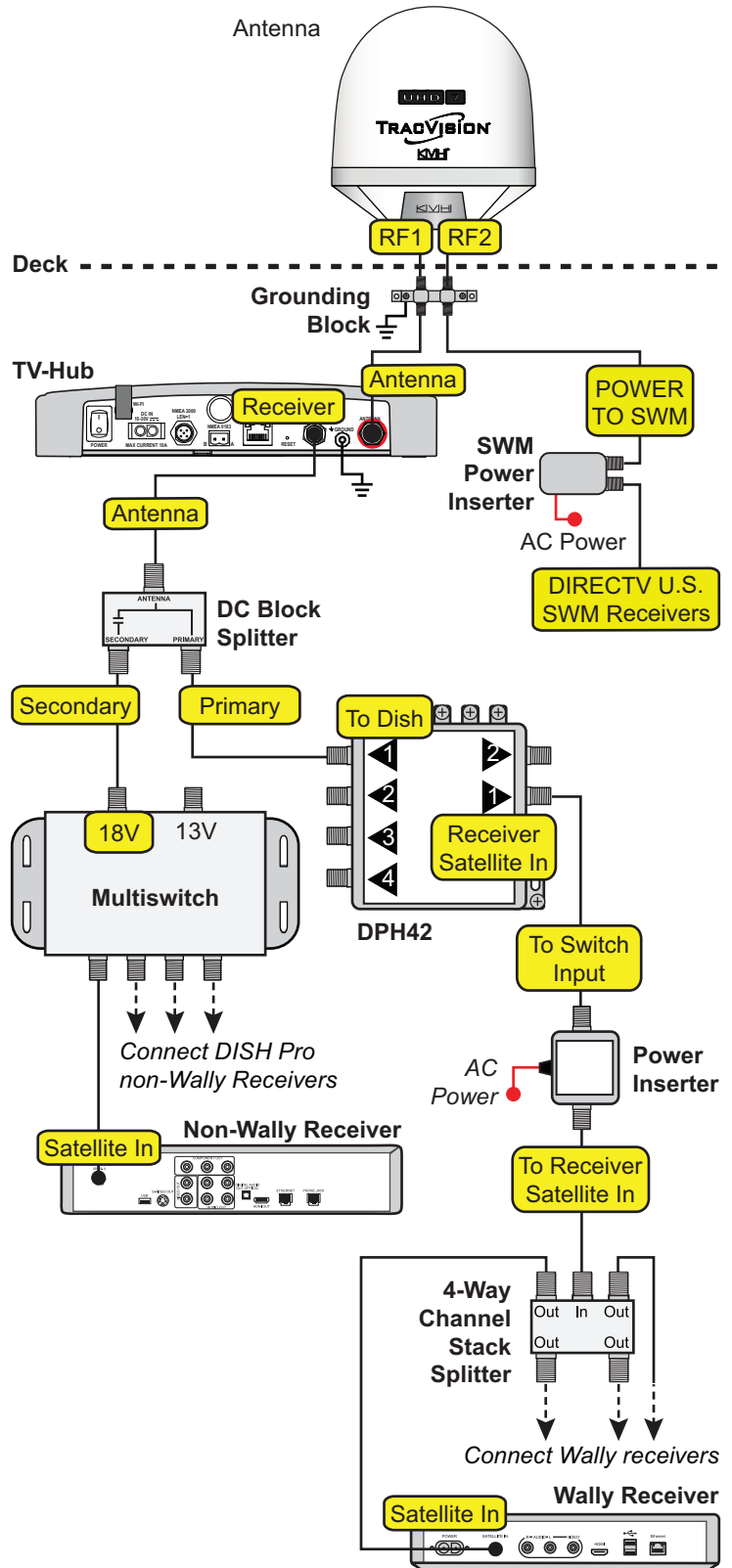

A Continued Using Wally Receivers

Running a Check Switch Test on Wally Receivers

Follow these steps to run a Check Switch test of each Wally receiver connected to the TracVision system. (To run a Check Switch test on most other DISH Network or Bell TV receivers, refer to “Run a Check Switch Test” on page 30.)

- a. Ensure the antenna is tracking a DISH Network (e.g., 77W) satellite.
- b. Navigate to the Dish screen (Settings > Diagnostics > Dish).
- c. Select **Test Installation**.
- d. Wait up to 10 minutes for the test to complete and the receiver’s Program Guide to load. Once complete, the Check Switch test displays the current satellite, switch type “DPH42”, and a green check mark (see Figure 55).

Figure 55: Wally Receiver Check Switch Screen





Regulatory Compliance

European Union Compliance

Hereby, KVH Industries, Inc. declares that the radio equipment type TracVision UHD7 is in compliance with EMC Directive 2014/53/EU. For the full text of the EU Declaration of Conformity, go to www.kvh.com/euconformity.

Federal Communications Commission Compliance



The TracVision system complies with Class B of Part 15 of the FCC (Federal Communications Commission) rules for radiated and conducted emissions.

Contains FCC ID: QQQWF111

Use Conditions:

This device complies with part 15 of the FCC Rules. Operation is subject to the following two conditions:

1. This device may not cause harmful interference.
2. This device must accept any interference received, including interference that may cause undesired operation.

Note:

This equipment has been tested and found to comply with the limits for a Class B digital device, pursuant to Part 15 of the FCC Rules. These limits are designed to provide reasonable protection against harmful interference in a residential installation. This equipment generates, uses, and can radiate radio frequency energy and, if not installed and used in accordance with the instructions, may cause harmful interference to radio communications. However, there is no guarantee that interference will not occur in a particular installation. To determine if the equipment is interfering with radio or television reception, remove or apply power to the equipment and observe if the interference goes away, or returns, when the unit is off or on. The user is encouraged to try to correct the interference by one of the following measures:

- Reorient or relocate the receiving antenna.
- Increase the separation between the equipment and receiver.
- Connect the equipment into an outlet on a circuit different from that to which the receiver is connected.
- Consult KVH for assistance.

Important:

- To meet FCC Requirements, this equipment must be installed following the steps detailed in the product installation manual.
- This equipment contains no user serviceable parts. Opening this unit will violate the warranty and may result in this equipment no longer complying with FCC requirements for Class B digital devices.





www.kvh.com



KVH Industries A/S
EMEA Headquarters
Kokkedal, Denmark
Tel: +45 45 160 180 Fax: +45 45 160 181
E-mail: info@emea.kvh.com

KVH Industries, Inc.
World Headquarters
Bristol, RI U.S.A.
Tel: +1 401 847 3327 Fax: +1 401 849 0045
E-mail: info@kvh.com

KVH Industries Pte Ltd.
Asia-Pacific Headquarters
Singapore
Tel: +65 6513 0290 Fax: +65 6472 3469
E-mail: info@apac.kvh.com