

# TracVision UHD7 SWM Expansion Kit Installation Instructions



These instructions explain how to install a SWM (single-wire multiswitch) expansion kit for use with the TracVision® UHD7. With a SWM expansion kit installed, the TracVision system can far exceed the number of tuners that are supported by the standard system, allowing you to connect even more receivers/DVRs to the system.

KVH Kit Part No.	Tuners Supported
72-0897	52
72-0898	104

*NOTE: Complete instructions on how to use the system are provided in the Help.*

---

## Installation Steps

1. Inspect Parts and Get Tools ..... 3
2. Remove the Radome or Hatch..... 4
3. Bypass the Internal DSWM ..... 5
4. Connect Cables to the Antenna ..... 7
5. Wire the Polarity Locker..... 8
6. Wire the SWM Expander ..... 9
7. Seat the DSWMs..... 10
8. Wire the Receivers ..... 11
9. Configure the Receivers..... 13

---

## Who Should Install the Expansion Kit?

To ensure a safe and effective installation, KVH recommends that a KVH-authorized marine technician install the TracVision UHD7 SWM Expansion Kit. KVH-authorized technicians have the tools and electronics expertise necessary to modify the antenna system. To find a technician near you, visit [www.kvh.com/wheretogetservice](http://www.kvh.com/wheretogetservice).

---

## Technical Support

If you need technical assistance, please contact KVH Technical Support:

### North/South America, Australasia

Phone: +1 401 847-3327

Email: [support@kvh.com](mailto:support@kvh.com)

(Mon.-Fri., 9 am-6 pm; Sat., 9 am-2 pm ET, -5 GMT)

### Europe, Middle East, Africa, Asia-Pacific

Phone: +45 45 160 180

Email: [support@emea.kvh.com](mailto:support@emea.kvh.com)

(Mon.-Thu., 8 am-4:30 pm; Fri., 8 am-2 pm, +1 GMT)

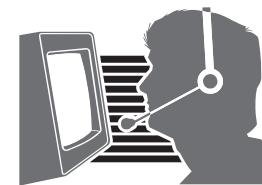

# 1 Inspect Parts and Get Tools

Before you begin, follow the steps below to ensure you have everything needed to complete the installation.

- a. Unpack the box and carefully examine all of the supplied parts to ensure nothing was damaged in shipment. Save the packaging for future use.
- b. Gather the tools and materials listed below. You will need these items to complete the installation.
  - #2 Phillips screwdriver
  - 7/16" open-end wrench
  - Flush cutters
  - #2 Phillips torque screwdriver set to 5 in.-lbs
  - 7/16" torque wrench set to 15 in.-lbs
  - 7/16" torque wrench set to 20 in.-lbs
  - Satellite TV receivers and/or DVRs
  - RG-6 or RG-11 RF coax cabling with Snap-N-Seal<sup>®</sup> F-connectors (see [Figure 1](#))
  - Silicone sealant, self-vulcanizing tape, or equivalent

Figure 1: RF Cable Type Requirements

For Lengths	Use RF Cable Type
Up to 100 ft (30 m)	RG-6
Up to 200 ft (60 m)	RG-11

**NOTE:** The RF cables connecting the antenna to the SWM expander should not exceed 100 ft (30 m) in length. Only RF cables connecting the 8-way splitters, receivers, and DVRs can be wired over 100 ft (30 m) (up to 200 ft (60 m)).

## 2 Remove the Radome or Hatch

Follow the steps below to either remove the radome or the service hatch to access the antenna's DSWM and DSWM bypass bracket.



### CAUTION

To prevent injury, be sure to disconnect all power from the antenna before proceeding. Power must remain disconnected for the duration of this procedure.

- a. Power off and unplug the TV-Hub and the SWM power inserter to disconnect all power from the antenna.

### TracVision UHD7 Standard and Tapered Baseplate Versions (26" (66 cm))

Using a #2 Phillips screwdriver, remove the six #10-32 Phillips screws securing the radome to the baseplate (see [Figure 2](#)). Carefully lift the radome straight up until clear of the antenna assembly and set it aside in a safe place.

If you keep the radome topside, secure it with a lanyard to prevent it from falling overboard. Also, do not place the radome on a hot steel deck – the heat may warp the radome.

### TracVision UHD7 Large Dome Version (32" (82 cm))

Using a #2 Phillips screwdriver, remove the eleven M4 screws securing the service hatch to the antenna's baseplate (see [Figure 3](#)).

Set the hatch aside in a safe place.

Figure 2: Removing the Radome (Standard Version Shown)

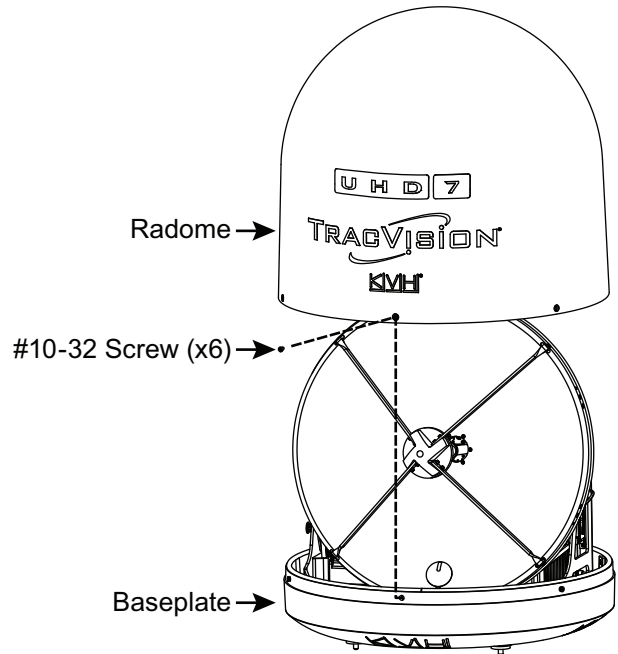
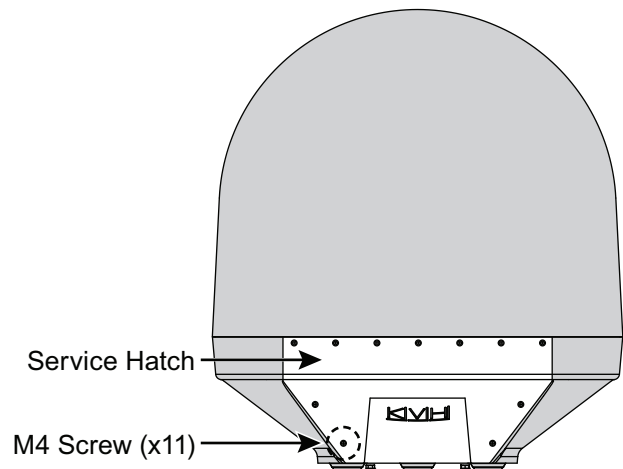

Figure 3: Removing the Service Hatch (32" (82 cm) Dome)



# 3 Bypass the Internal DSWM

Follow the steps below to bypass the UHD7 antenna's DSWM by connecting its RF cables to the bypass bracket.

- a. Locate the DSWM inside the UHD7 antenna and identify the RF cables connected to it. Note that RF4 and RF5 are already connected to the DSWM bypass bracket (see Figure 4).

*NOTE: To avoid damage, avoid excessive twisting or sharp bends in the cables while tightening.*

- b. Using a 7/16" open-end wrench, carefully disconnect each of the cables shown in Figure 5 (RF2, RF1, 13V, and 18V), and connect them, one at a time, to the corresponding connectors on the DSWM bypass bracket.
- c. Tighten the connectors with a 7/16" torque wrench set to 15 in.-lbs.

Figure 4: RF Cables Connected to the Antenna's DSWM

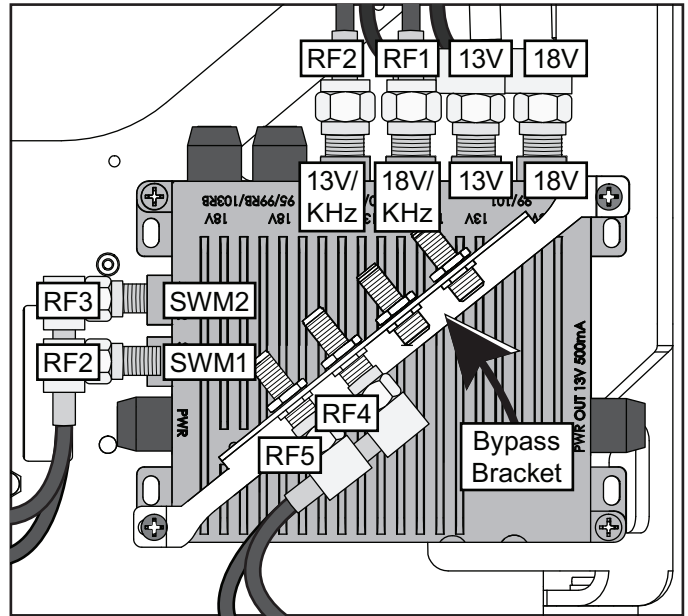
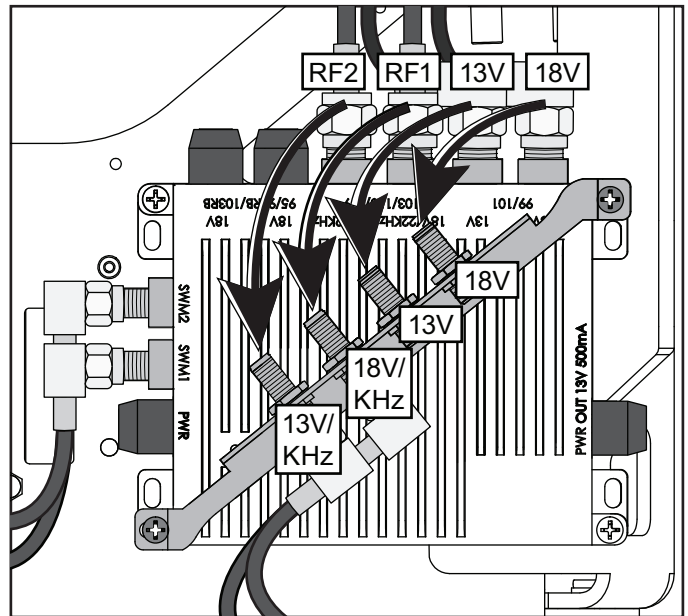

Figure 5: Connecting the Antenna Cables to the Bypass Bracket



# 3 Continued Bypass the Internal DSWM

- d. Using a 7/16" open-end wrench, carefully disconnect the RF2 and RF3 cables from the SWM1 and SWM2 connectors on the DSWM, and connect them, one at a time, to the corresponding connectors on the DSWM bypass bracket (see [Figure 6](#)).
- e. Tighten the connectors to 15 in.-lbs of torque.
- f. RF2, RF3, RF4, and RF5 should now be connected through the DSWM bypass bracket (see [Figure 7](#)).
- g. Neatly arrange the cables. Then rotate the antenna through its full range of motion, to ensure there is no interference.
- h. Inspect the inside of the antenna to make sure you have not left any tools or debris inside.
- i. Reinstall the radome (standard or tapered dome version antenna) or service hatch (large dome version antenna) onto the antenna and secure it in place with the screws you removed in ["Remove the Radome or Hatch"](#) on page 4. Tighten the screws to 5 in.-lbs of torque.
- j. Protect and hide the radome screws with six new screw covers (*supplied in kit*).

Figure 6: Connecting the RF2 and RF3 Cables to the Bypass Bracket

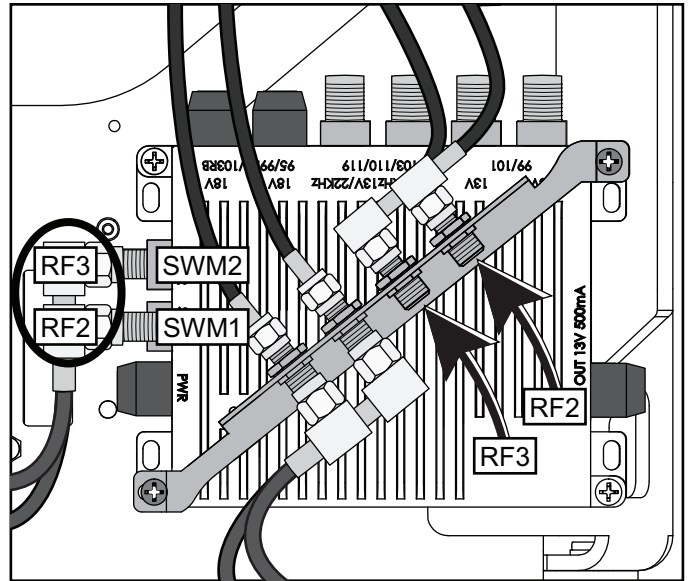
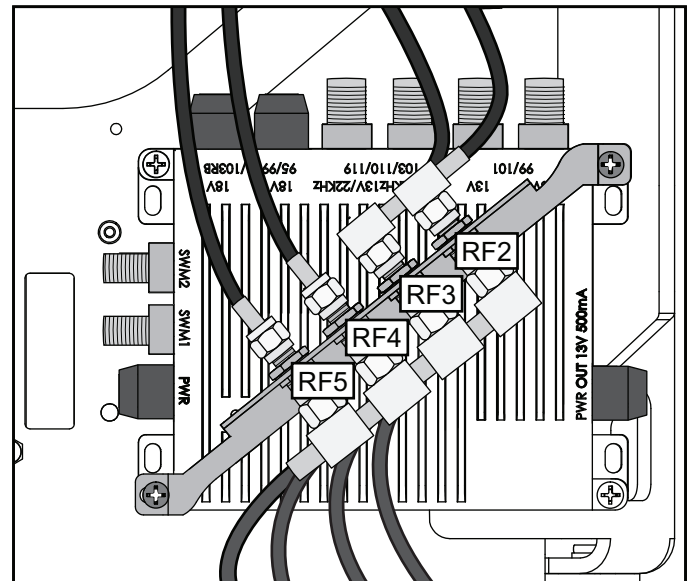

Figure 7: RF2, RF3, RF4, and RF5 Connected Through the Bracket



# 4 Connect Cables to the Antenna

Follow the steps below to connect cables to the RF connectors on the bottom of the antenna (see Figure 8).

- a. Clean and dry the connectors on the RF cables and the antenna with a solvent or alcohol.

	<b>CAUTION</b>
Observe the safe handling instructions in the Material Safety Data Sheet (MSDS) provided with the silicone grease.	

- b. Fill half of the inner body of the RF1 cable's connector with the supplied silicone grease.
- c. Connect and **SLOWLY** hand-tighten the RF1 cable to the "RF1" connector on the bottom of the antenna, allowing the grease to diffuse and settle into the entire space within the connector.
- d. Make sure the RF cable is hand-tightened all the way into the connector. Then tighten it with a 7/16" torque wrench to 20 in.-lbs.
- e. Wipe off any excess grease from the outside of the connector.
- f. Repeat steps b-e to connect RF cables to the antenna's RF2, RF3, RF4, and RF5 connectors.
- g. Clearly label all RF cables at both ends for easy identification later.
- h. Route the cables belowdecks through the cable access hole. Leave an adequate service loop, approximately 8" (20 cm) of slack, in the cables for easy serviceability.
- i. Seal the RF cable connections with silicone sealant or equivalent and weatherproof the cable access hole as required.

Figure 8: Connectors on the Bottom of the Antenna

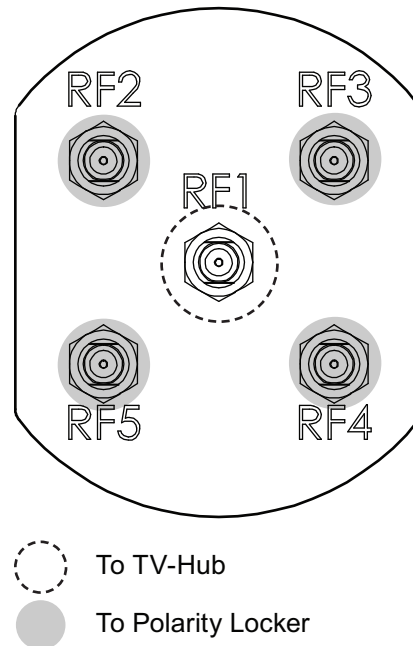

# 5 Wire the Polarity Locker

Follow the steps below to connect the antenna's RF cables to the TV-Hub and polarity locker.

- a. Reconnect the RF1 cable from the antenna to the "Antenna" jack on the TV-Hub (see [Figure 9](#)). Hand-tighten the RF cable until it is all the way into the "Antenna" jack.

**IMPORTANT!**

Do not connect anything other than the antenna's RF1 cable to the "Antenna" jack. The TV-Hub supplies voltage that will damage other devices, such as multiswitches, receivers, DVRs, etc.

- a. Connect the RF2, RF3, RF4, and RF5 cables from the antenna to the connectors on the polarity locker with the corresponding voltage/tone, as shown in [Figure 10](#).
- b. Connect an RF cable from the "DC Input" connector of the polarity locker to the "Power to SWM" connector on a SWM power inserter (supplied in kit).

**NOTE:** Do *not* connect the SWM power inserter's AC power cable to vessel power at this time. Power will be connected in "[Configure the Receivers](#)" on [page 13](#).

- c. Connect the hoop of the grounding wire (supplied in kit) to the ground lug on the polarity locker. Connect the other end to ship's ground.
- d. Tighten all of the RF connections with a 7/16" torque wrench set to 15 in.-lbs.

Figure 9: TV-Hub Antenna Connection to RF1

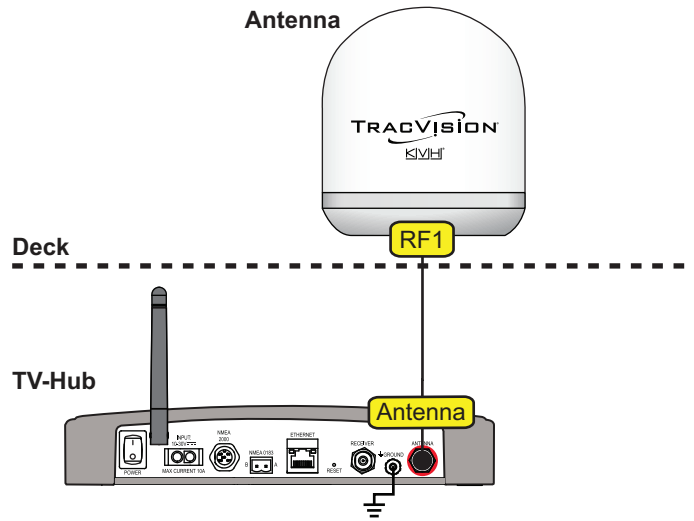
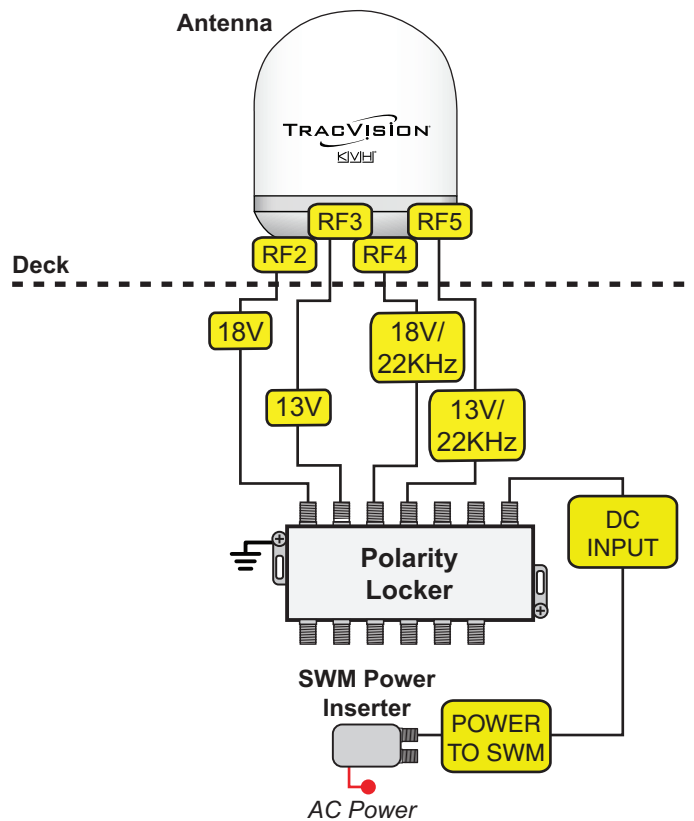

Figure 10: Polarity Locker Connection to RF2, RF3, RF4, and RF5



# 6 Wire the SWM Expander

Follow the steps below to connect the polarity locker to the SWM expander.

- a. Connect the polarity locker outputs (1-4) to the SWM expander in parallel positions, as shown in [Figure 11](#) (e.g., the antenna's RF2 cable connects through the polarity locker's "LNB1/18V" connector, and the parallel cable connected to "Out 1" connects to the SWM expander's "18V" connector).
- b. Connect the hoop of the grounding wire (supplied in kit) to the ground lug on the SWM expander. Connect the other end to ship's ground.
- c. Tighten all of the RF connections with a 7/16" torque wrench set to 15 in.-lbs.

Figure 11: SWM Expander Connected to Polarity Locker

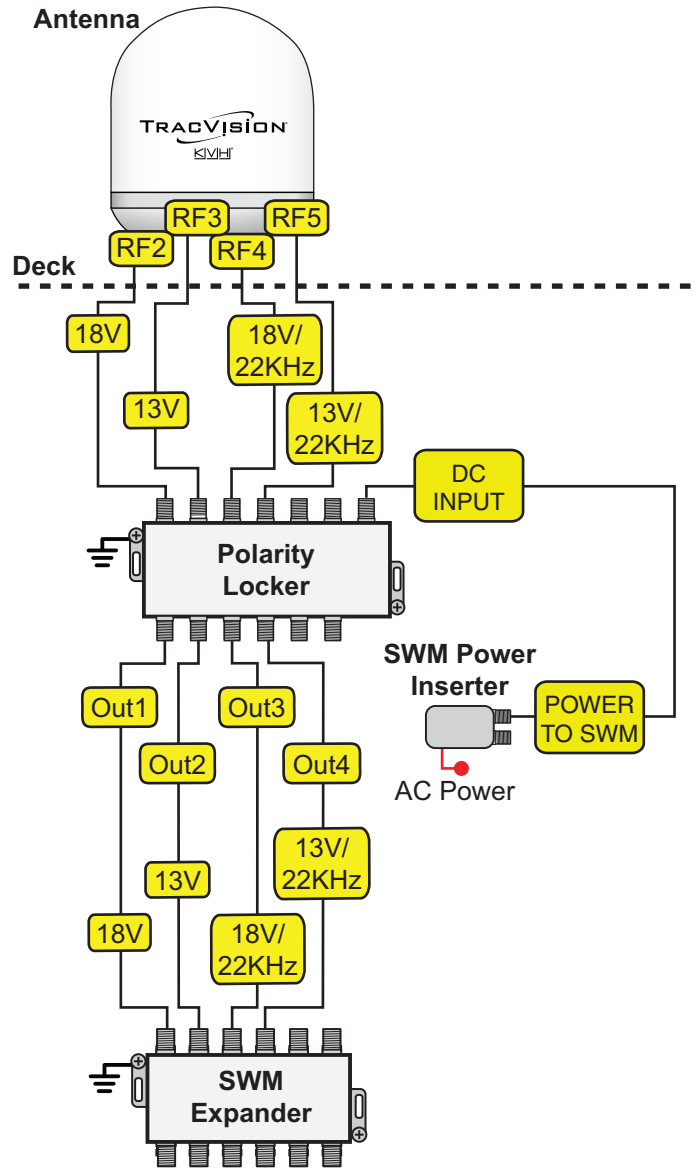

# 7 Seat the DSWMs

Follow the steps below to seat up to four DSWMs in the SWM expander.

- Seat up to four DSWMs in the SWM expander. Secure them in place with the locking tabs (see [Figure 12](#)).
- Connect an RF jumper cable (supplied in kit) from each DSWM's "PWR" connector to a "PWR-SWM" connector (labeled "PWR-SWM1" through "PWR-SWM4") on the SWM expander.
- Connect a SWM power inserter (supplied in kit) to a "DC PWR IN" connector (labeled either "DC PWR IN-1" or "DC PWR IN-2") on the SWM expander.

**NOTE:** Connect a second SWM power inserter to "DC PWR IN-2" if your installation exceeds two DSWMs.

**NOTE:** Do **not** connect the SWM power inserter's AC power cable to vessel power at this time. Power will be connected in "[Configure the Receivers](#)" on page 13.

Figure 12: DSWMs Seated in the SWM Expander

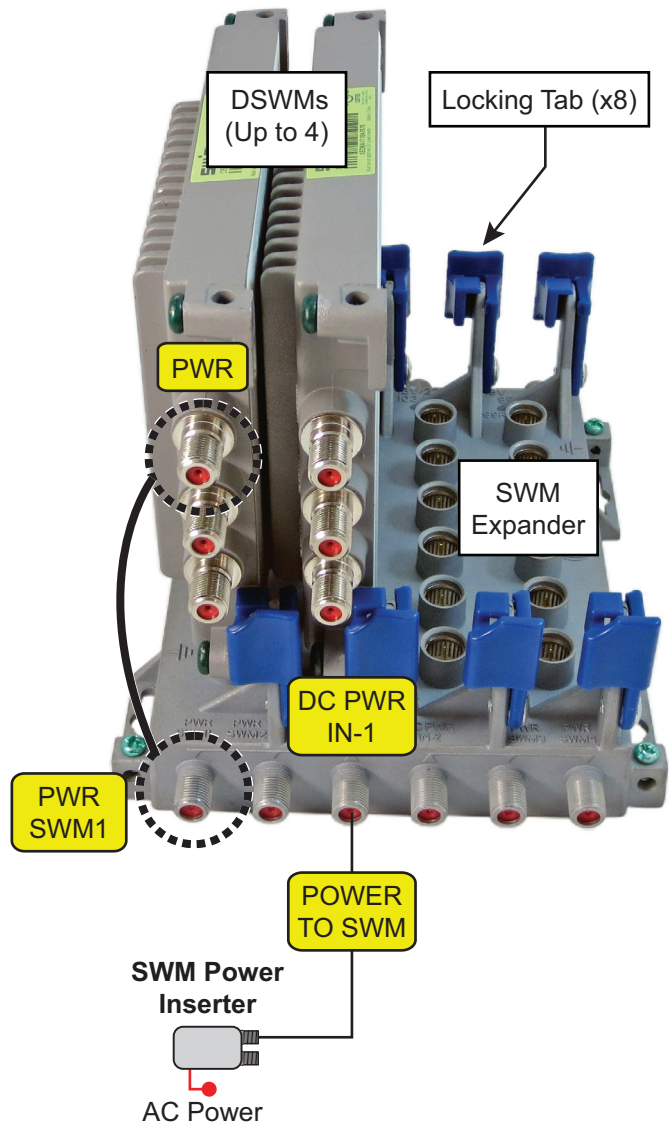

# 8 Wire the Receivers

Follow the steps below to wire the receivers to the DSWMs in the SWM expander.

- a. As shown in [Figure 13](#), connect an RF cable (supplied in kit) from the “SWM1” connector on a DSWM to the “SWM” input on a 2-way SWM splitter (supplied in kit).

**IMPORTANT!**

When wiring the receivers, be sure to keep the number of splits to no more than two per path.

- b. Connect the 2-way SWM splitter’s outputs to the “SWM” inputs on two 8-way SWM splitters (supplied in kit).
- c. Connect the 8-way SWM splitter’s outputs to the “Satellite In” jacks on the receivers/DVRs (or “Network” jack when connecting a Genie client). Connect any combination of SWM devices that add up to 13 or fewer tuners. Refer to the table below, as necessary:

SWM Device	No. Tuner(s)
SWM Receiver	1
SWM DVR	2
Genie (HR34/HR44)	5
Genie (HR54)	7
Genie Client	0

*NOTE: Genie clients reserve 0 tuners, but only three Genie clients can be active at one time.*

- d. Terminate any unused outputs on the splitters with 75Ω terminators and tighten all connections with a 7/16" torque wrench set to 20 in.-lbs.
- e. Repeat steps a-d to connect SWM splitters and receivers to the DSWM’s “SWM2” connector (see [Figure 14](#) on the next page). You can connect any combination of SWM devices that up to 13 tuners on “SWM2” (26 total, between “SWM1” and “SWM2”).
- f. Repeat steps a-e to connect SWM splitters and receivers to each DSWM seated in the SWM expander, as needed.

Figure 13: Wiring Up to 13 Receivers to SWM1

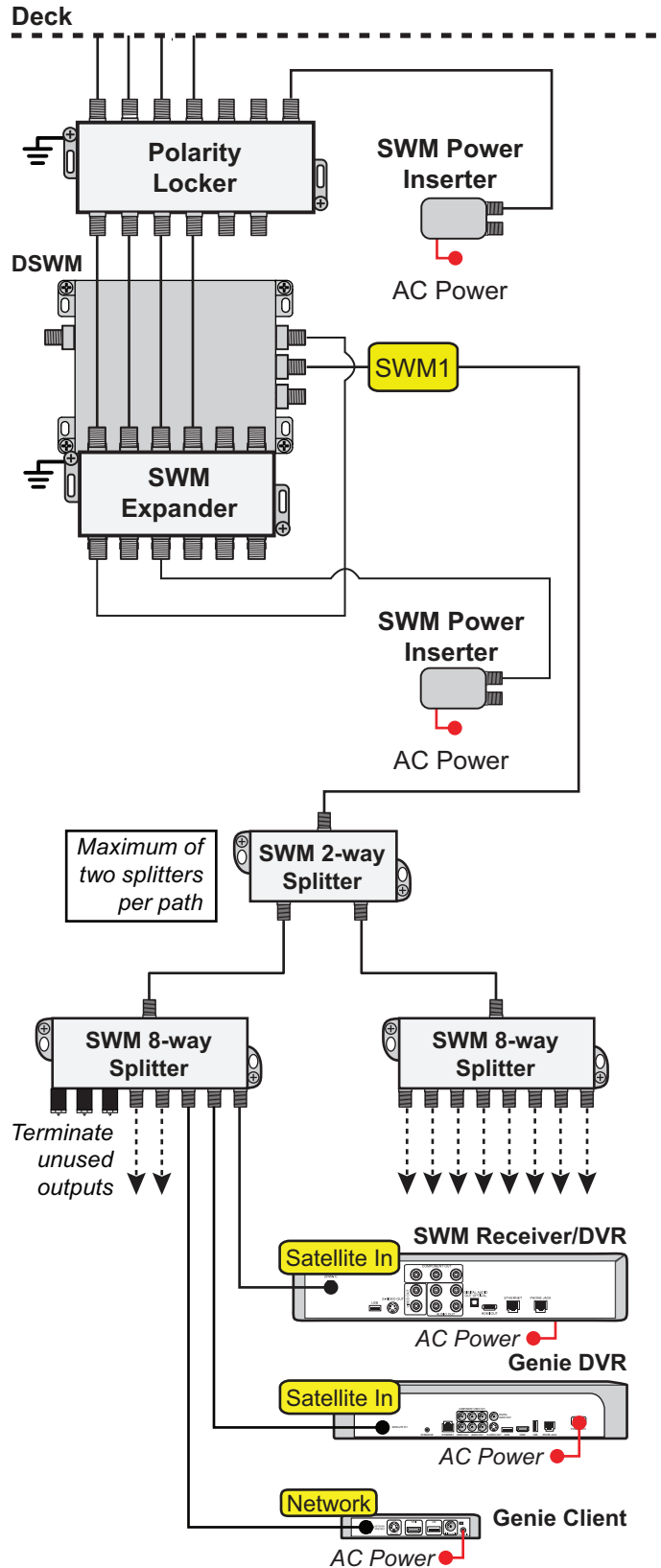

# 8 Continued Wire the Receivers

Figure 14: Wiring 26 Receivers to Each DSWM

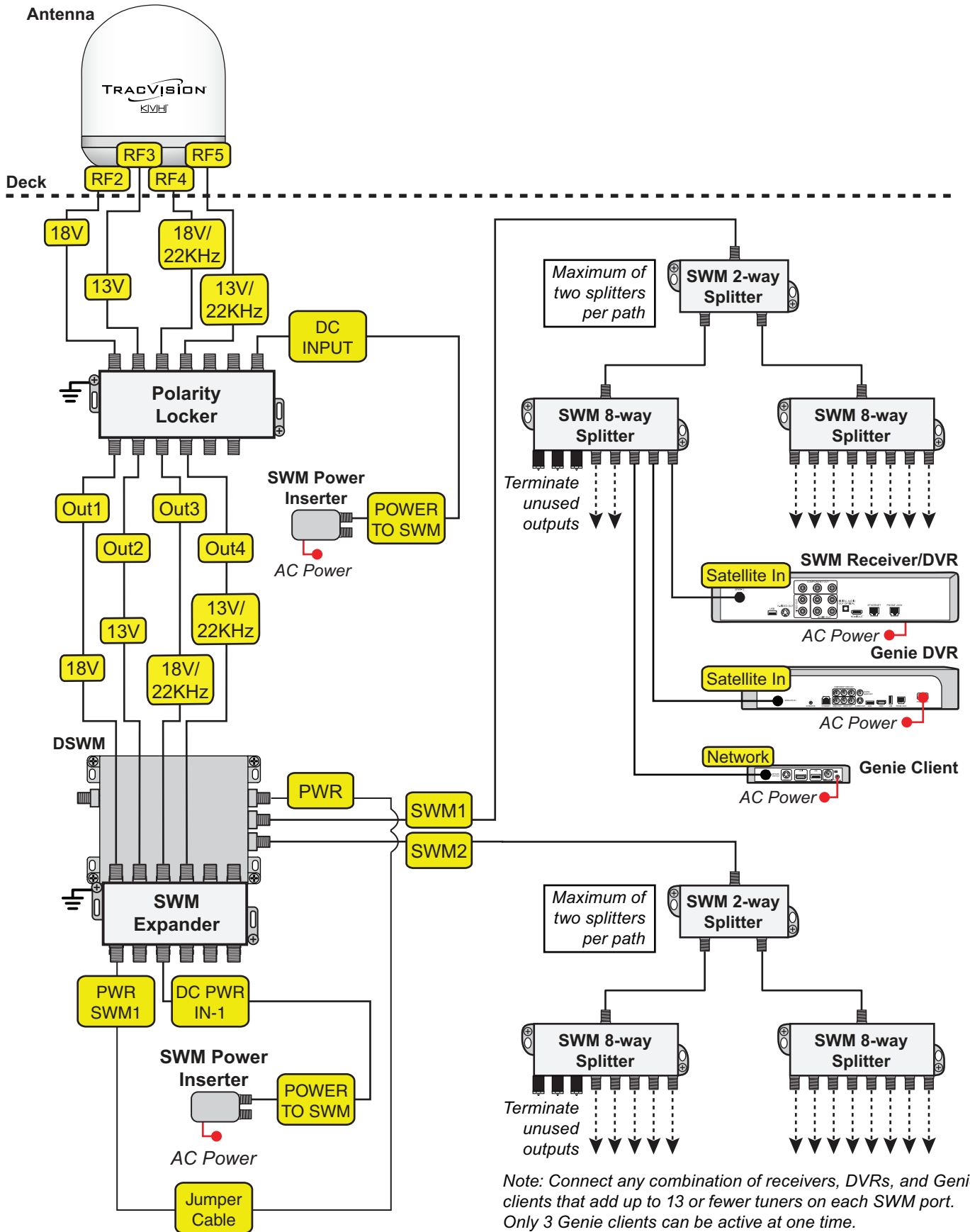

# 9 Configure the Receivers

Follow the steps below to connect power to the system and set or verify the dish type or configuration of each SWM receiver and/or DVR connected to the TracVision system.

*NOTE: Refer to your selected receiver/DVR manual for specific configuration instructions.*

- a. Connect power to the TV-Hub and SWM power inserters. For details, refer to the *TracVision UHD7 Installation Guide*.
- b. Press the Menu button on the receiver's/ DVR's remote control to display its menu on the connected television.
- c. Navigate to the Satellite screen (Settings > Settings & Help > Satellite) and select **Repeat Satellite Setup**.
- d. At the Satellite Dish Setup menu, set the Dish Type and RB/INTL to the settings below. Switch Type should auto-populate:  
Dish Type: **SL3 LNB**.  
RD/INTL: **None Selected**  
Switch Type: **SWM Module 15 CH**
- e. Make any necessary changes, then choose **Continue** to complete setup (see [Figure 15](#)).
- f. Repeat these steps for each connected receiver and DVR.

The procedure is complete!

Figure 15: DIRECTV SWM Receiver/DVR Configuration

