

Installation Guide

TracNet™ H30



TracNet™ H30 Installation Guide



This guide explains how to install the TracNet H30 hybrid VSAT, cellular, and Wi-Fi communications system. Operation instructions are provided in the Quick Start Guide.

Table of Contents

Important Safety Information.....	2	No-Transmit Zones (Optional).....	27
Inspect Parts and Get Tools.....	3	Test the System	28
Plan the Antenna Installation.....	4	Connect Vessel Network Devices.....	29
Plan the BDU Installation.....	7	Connect the Vessel Phone.....	30
Prepare the Antenna Site	8	Add Third-party SIM (Optional).....	31
Prepare the Antenna Cable	9	Add Backup or Alternate WAN Connection (Optional)	34
Wire the Antenna	10	Educate the Customer	35
Mount the Antenna.....	11		
Mount the BDU (Hub+ Option).....	13	Appendices	
Mount the BDU (Hub Option)	14	Terminating RG-58 Cable	36
Wire the BDU.....	15	Connecting Pigtail Cables to the Antenna Cable.....	39
Connect an NMEA Talker	16	Approved Cable Types	40
Connect Power (Hub+ Option)	17	Verifying the NMEA 0183 Message	41
Connect Power (Hub Option)	19	Wiring Diagram (Hub+ Option).....	42
Turn On the System.....	20	Wiring Diagram (Hub Option).....	43
Configure the System.....	21		

CAUTION - RF Radiation Hazard



The antenna transmits radio frequency (RF) energy that is potentially harmful. Whenever the system is powered on, make sure everyone stays more than 32 ft (10 m) away from the antenna within its 7.7-75° elevation range. No hazard exists directly above the antenna and anywhere below the antenna's mounting plane.

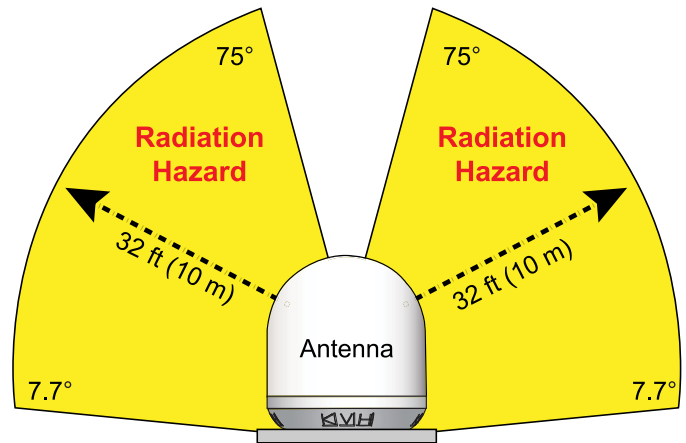

Who Should Install the System?

To ensure a safe and effective installation, only a KVH-certified marine technician should install the system. To find a technician near you, visit www.kvh.com/wheretogetservice.

Technical Support

Within Continental U.S.A.: 1 866 701-7103
Worldwide: +1 401 851-3806
Email: mvbsupport@kvh.com

Trademark Information

KVH, TracNet, KVH ONE, and the unique light-colored dome with dark contrasting baseplate (Reg. No. 2,864,752) are trademarks of KVH Industries, Inc.

All other trademarks are the property of their respective companies.

Disclaimer

Every effort has been made to ensure the correctness and completeness of the material in this document. No company shall be liable for errors contained herein. The information in this document is subject to change without notice. No warranty of any kind is made with regard to this material, including, but not limited to, the implied warranties of merchantability and fitness for a particular purpose.

Feedback

If you have any comments regarding this manual, please email them to manuals@kvh.com. Your input is greatly appreciated!

Important Safety Information



This icon indicates a danger, warning, or caution notice. Be sure to read these carefully to avoid injury.



WARNING Risk of Electric Shock

If any component of the TracNet H30 system becomes damaged and/or no longer functions normally, disconnect it from vessel power, secure it from unintended operation, and contact KVH Technical Support (see “[Technical Support](#)” on page 1). All repairs or modifications must be performed by a trained, KVH-certified technician. If you are a KVH-certified technician, you still must contact KVH Technical Support prior to conducting any repairs or modifications to the equipment.



WARNING Risk of Explosion

Do not operate the TracNet BDU (or any other electrical device) in an environment where flammable gases, vapors, or dusts are present. In addition, do not operate the unit in an environment with a temperature outside its 5° F to 131° F (-15° C to 55° C) temperature range.



CAUTION Risk of Electric Shock

Failure to ground the H30 system properly to ship’s ground will cause an unsafe floating ground condition, risking potentially lethal electric shock. See “[Connect Power \(Hub+ Option\)](#)” on page 17 or “[Connect Power \(Hub Option\)](#)” on page 19 for details on the proper grounding of the equipment.



CAUTION RF Radiation Hazard

The antenna transmits up to 3 watts of radio frequency (RF) energy that is potentially harmful. Whenever the system is powered on, make sure everyone stays more than 32 feet (10 m) away from the antenna. No hazard exists directly above or below the antenna.

Inspect Parts and Get Tools

Before you begin, follow these steps to ensure you have everything needed to complete the installation.

1. Unpack the box and ensure it contains everything shown in Figure 1 and on the Kitpack Contents List. Save the packaging for future use.

Figure 1: TracNet H30 System Components

Antenna

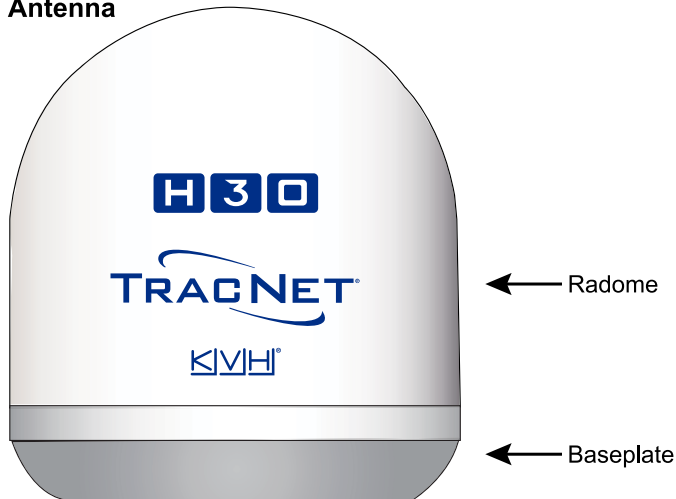

Below Deck Unit (BDU)

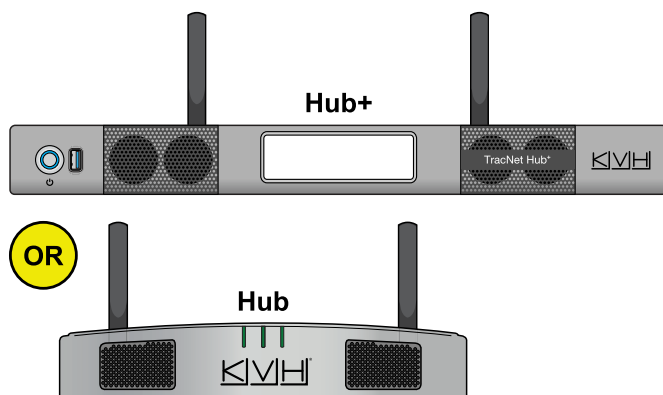

Note: This manual refers to the TracNet Hub+ or Hub as the BDU (Below Deck Unit).

IMPORTANT!

Always lift the antenna by the baseplate and never by the radome or any portion of the internal antenna assembly.

2. Carefully examine all of the supplied parts to ensure nothing was damaged in shipment.

3. Gather the following tools and materials:
 - Flat-head and Phillips-head screwdrivers
 - Electric drill and 5/16" (8 mm) bit
 - 1.5" (38 mm) hole saw
 - Light hammer and center punch
 - Adhesive tape
 - 7/16" socket on a 4" extension (for mounting bolts) and 1/2" socket or wrench (for mounting nuts)
 - Self-vulcanizing tape or equivalent
 - Heat gun (for heat shrink)
 - Eye protection
 - Shop towels
 - Voltmeter
 - Utility knife
 - Flush cutters
 - Wire stripper/terminal crimper
 - File
 - Isolation transformer, if required (see ["Connect Power \(Hub+ Option\)"](#) on page 17)
 - Cable termination tools, if necessary (see ["Prepare the Antenna Cable"](#) on page 9)
 - NMEA 0183 or NMEA 2000 talker and interface cable (see ["Connect an NMEA Talker"](#) on page 16)
 - Laptop PC or Apple® or Android™ smartphone/tablet with the latest H-series antenna software downloaded from the KVH Partner Portal (www.kvh.com/partners), or a smartphone/tablet with the KVH Connect app installed and loaded with the latest antenna software

IMPORTANT!

Be sure to download the correct version of software for the system's BDU type:

Hub+ filename: Hxx_AC-BDU-<version no.>.bin

Hub filename: Hxx_DC-BDU-<version no.>.bin

Plan the Antenna Installation

Before you begin, be sure the designated install location meets the following guidelines.

IMPORTANT!

Damage caused by an improper installation is not covered under KVH warranty.

Choose a Suitable Location

- Select a location that is as close as possible to the intersection of the vessel's centerline and midships.
- Temperature must be within the operating range (-30°C to 55°C (-22°F to 131°F)).
- Be sure to mount the antenna near enough to the BDU to allow you to connect the 50 ft (15 m) antenna cable (supplied in kit) between them, while still maintaining sufficient slack in the cable to account for appropriate bend radius and service loops.

Note: If you need to use a longer cable, refer to "Prepare the Antenna Cable" on page 9.

Mounting Structure Requirements

Make sure the mounting surface is flat, level (within $\pm 2^\circ$), and wide enough to accommodate the antenna's base. Also make sure that the structure is strong enough to withstand the weight of the antenna (25 lbs, 11.3 kg), as well as other cumulative forces related to expected operating conditions, such as ice, snow, wash down, and maximum expected values of pitch, roll, and wind pressure (including gusts).

Recommendation: Vibration of the mounting surface should measure less than 0.51 gRMS total, and also less than 0.11 gRMS at the following resonant frequencies:

- Vertical: 62-93 Hz
- Horizontal: 21-30 Hz, 63-73 Hz, 90-92 Hz

Note: Ship's crew should consult with the shipyard to ensure that the antenna mounting surface vibration never exceeds the above stated conditions at any time during its life.

Figure 2: Antenna Dimensions

Front View

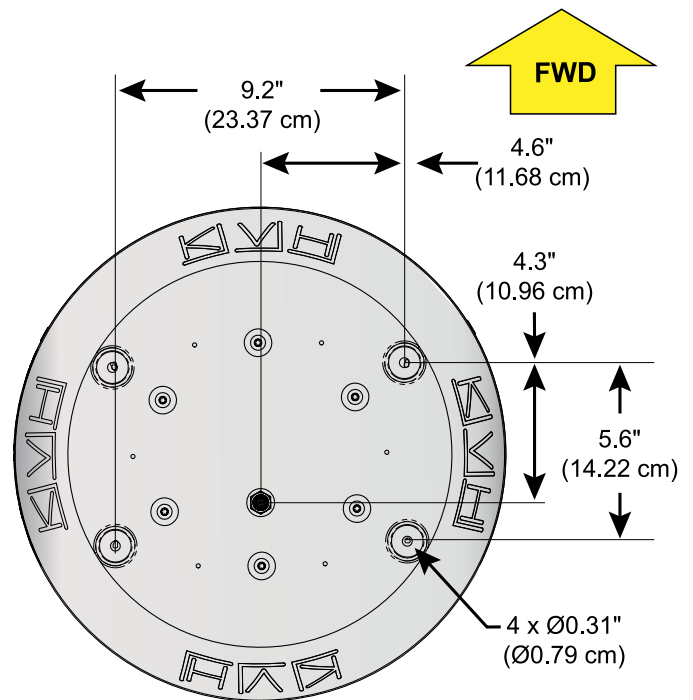
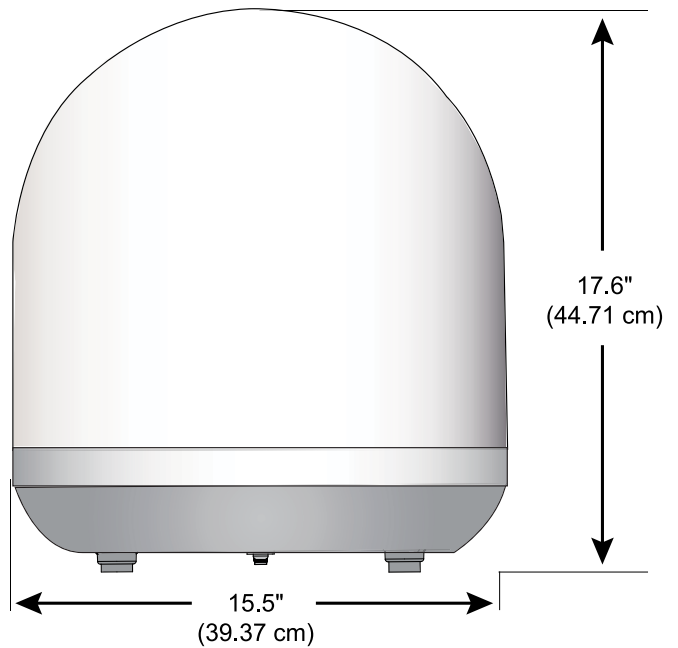

Bottom View

Pedestal Structure Requirements

If a pedestal is going to be used, it must meet the following minimum requirements.

Pedestal Height (A)	3.28 ft (1 m)	6.56 ft (2 m)	9.84 ft (3 m)	13.12 ft (4 m)
Tube OD (B)	5.0" (127 mm)	5.0" (127 mm)	5.0" (127 mm)	8.0" (203.2 mm)
Tube Wall Thickness (C)	0.25" (6.35 mm)	0.25" (6.35 mm)	0.25" (6.35 mm)	0.5" (12.7 mm)
Brace Height (D)	N/A	5.25 ft (1.6 m)	7.35 ft (2.24 m)	9.12 ft (2.78 m)
Brace OD (E)	N/A	2.25" (57.15 mm)	4.5" (114.3 mm)	7.0" (177.8 mm)
Brace Thickness (F)	N/A	0.25" (6.35 mm)	0.25" (6.35 mm)	0.25" (6.35 mm)
Brace Angle (G)	N/A	25°	25°	25°

Note: If the pedestal exceeds 3.28 ft (1 m), braces must be placed at 120° intervals. Sizing is based on Structural Steel Tubing 60,000 psi (415 MPa) minimum yield. For more details, refer to the Pedestal Specs Wizard (www.kvh.com/pedestalspecs).

Note: The ship's crew is responsible for fabricating and installing the pedestal.

Figure 3: Pedestal and Brace Dimensions

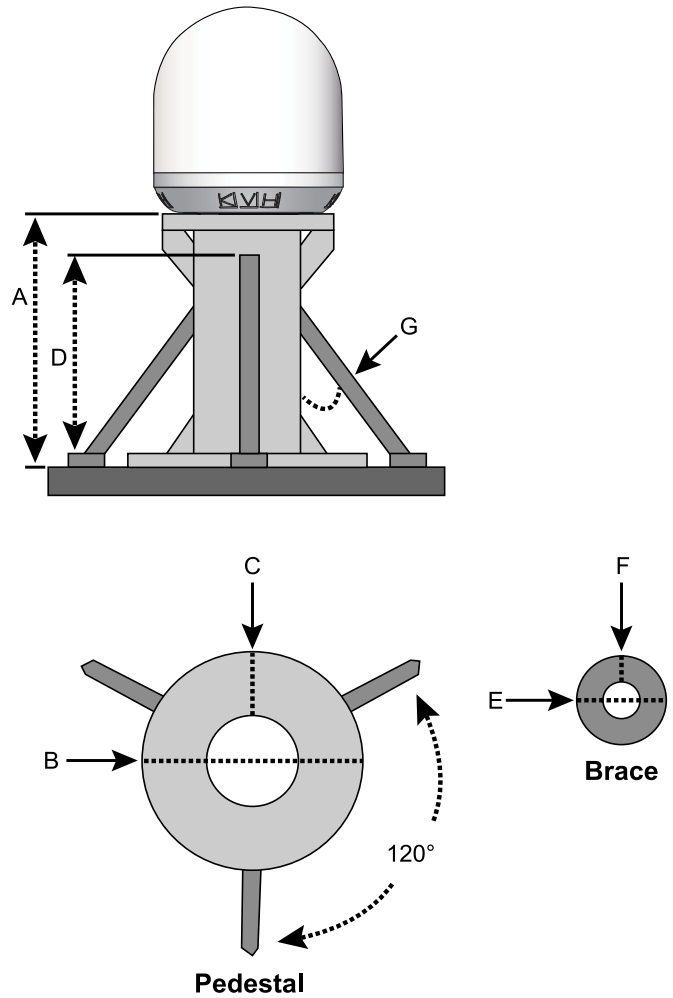

Prevent RF Radiation Exposure

Select a location that is well above any areas accessible to passengers and crew to reduce the risk of RF radiation exposure. (See [page 1](#) for an illustration of the hazard area.)

If mounting the antenna near an accessible area is unavoidable, you may configure one or two no-transmit zones to prevent transmissions in hazardous directions. (See “No-Transmit Zones (Optional)” on [page 27](#) for details.)

Minimize Satellite Blockage

The antenna requires a clear view of the sky to transmit and receive satellite signals. The fewer obstructions, the better the system will perform.

Figure 4: Blockage from Obstruction

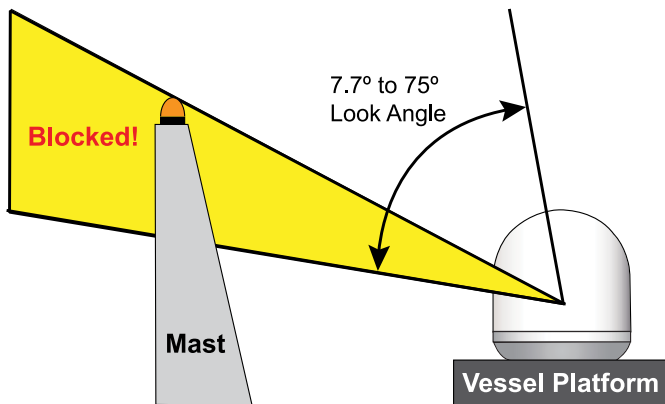

Prevent Electromagnetic Interference

Maintain a minimum distance of at least 5 ft (1.5 m) between the KVH antenna and any GPS/GNSS, cellular, or VHF antennas or other electromagnetic-sensitive equipment to avoid interference. Also maintain a minimum distance of at least 1 ft (30 cm) between the KVH antenna and any compasses.

IMPORTANT!

The interference guidelines provided in this manual cannot possibly account for all equipment variables and vessel conditions. Therefore, KVH recommends testing the KVH antenna at the chosen mounting location with the other vessel equipment in operation, if possible, prior to finalizing the installation. If interference occurs, relocate the antenna.

Avoid RF Interference

Although many variables determine the exact distance required between the antenna and radar/high-power radio transmitters, including transmit frequency/power, transmitter beam properties, and the reflective properties of nearby surfaces, consider the following general guidelines:

IMPORTANT!

RF emissions from radars and high-power radio transmitters may damage the antenna or impair its performance if it's improperly positioned within the beam path.

- Mount the KVH antenna as far away as possible from the radar and high-power radio transmitters.
- Do not mount the antenna at the same level as the radar. Most radar transmitters emit RF energy within an elevation range of -15° to $+15^\circ$. Therefore, mount the antenna outside this elevation range and at least 5 ft (1.5 m) away from the transmitter. If mounting the antenna directly above or below the radar, minimum distance is 3 ft (0.9 m).

IMPORTANT!

Never place the antenna in the beam path of the radar regardless of distance. Radar energy may damage the antenna or impair its performance.

Figure 5: Avoiding RF Interference

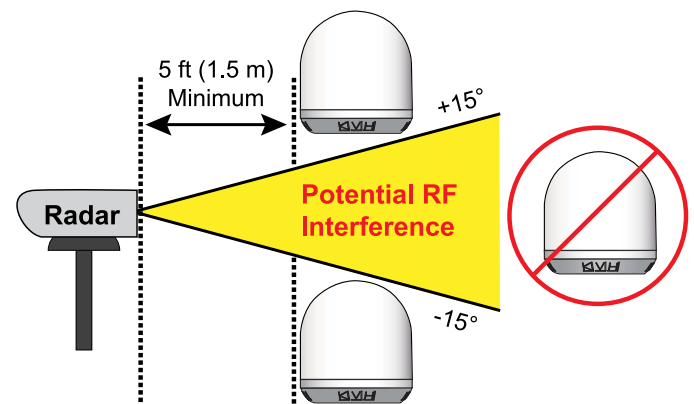

Plan the BDU Installation

Before you install the BDU, be sure the designated install location meets the following guidelines:

- Select a mounting location in a dry, well-ventilated area belowdecks away from any heat sources or salt spray.
- Be sure the location provides adequate Wi-Fi reception. Do not install it in an area surrounded by metal or near any electrical devices that emit RF noise.
- Be sure the front panel will be easily accessible to the user.
- Leave enough room behind the rear panel to accommodate the connecting cables with service loops, at least 14" (36 cm) in diameter.
- If you plan to connect the BDU to the vessel's onboard local area network (LAN), choose a location near an available Ethernet port.
- To use the supplied antenna cable, the BDU must be located within 50 ft (15 m) of the antenna. However, you can order a longer cable if necessary.
- The **Hub+** is designed for mounting in a standard equipment rack. It requires 1U of available space. It can also be mounted horizontally to a flat surface. *Installation details are provided in "Mount the BDU (Hub+ Option)" on page 13.*
- The **Hub** can be mounted horizontally or vertically to a flat surface. *Installation details are provided in "Mount the BDU (Hub Option)" on page 14.*

Figure 6: BDU Dimensions

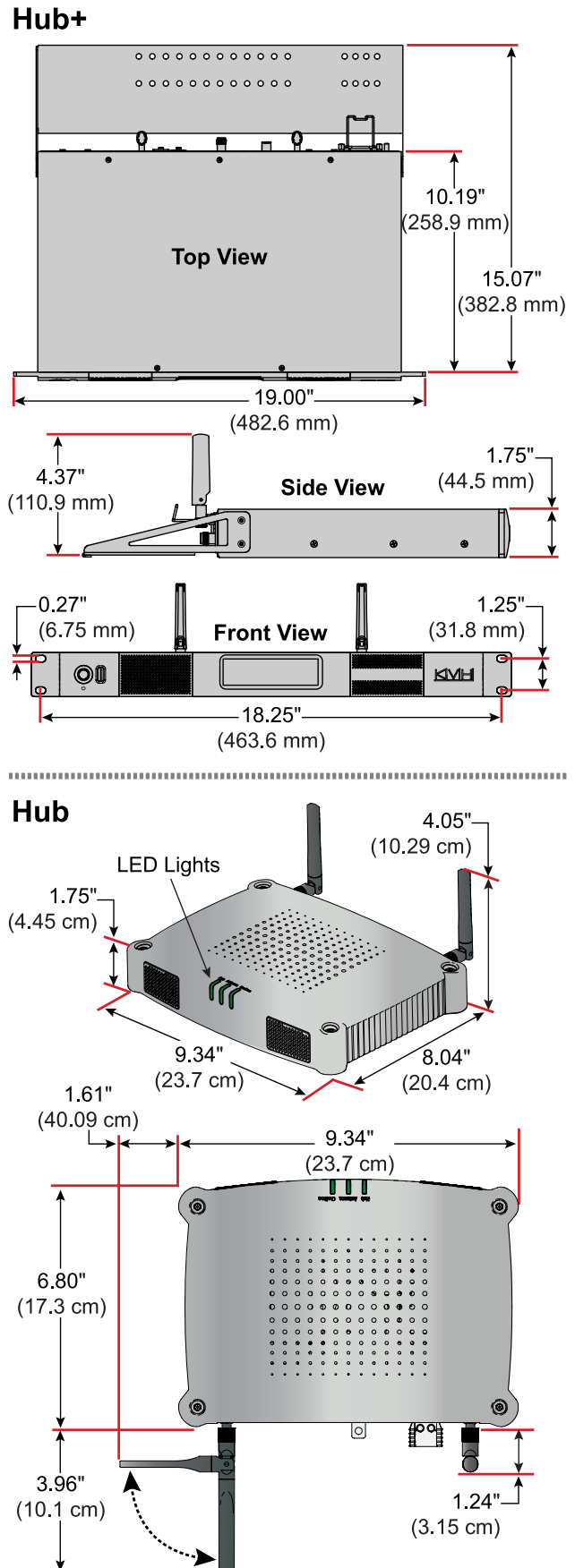

Prepare the Antenna Site

Once you have identified a suitable antenna mounting site, according to the guidelines provided in “[Plan the Antenna Installation](#)” on page 4, follow these steps to prepare the site for installation.

1. Unfold the antenna mounting template (supplied in the Customer Welcome Kit) and place it onto the mounting surface. Make sure the “FWD” (forward) arrow points toward the bow and is parallel to the vessel’s centerline.

Note: You don’t need to mount the antenna exactly on the vessel’s centerline, but the antenna’s forward arrow must be parallel to it.

Figure 7: Mounting Bolt Hole Pattern Examples

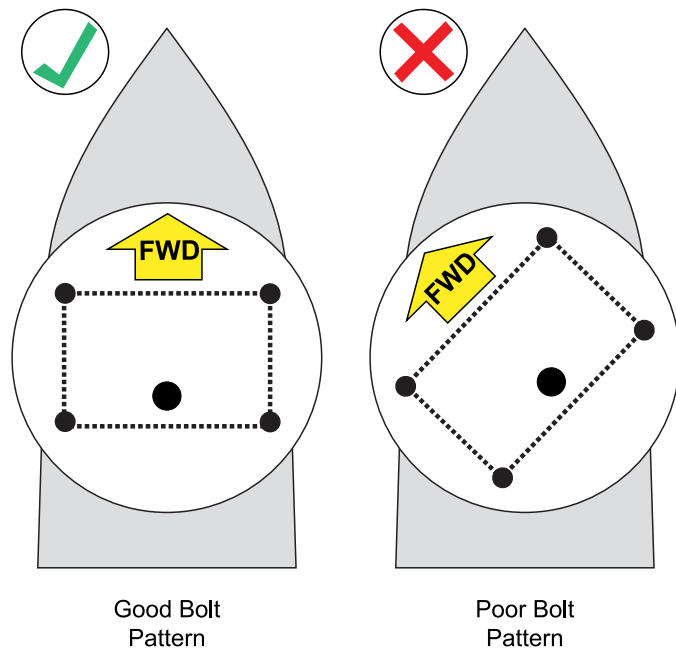

2. Using a light hammer and center punch, mark the locations for the four mounting holes and cable access hole on the mounting surface in the locations indicated on the template.
3. Drill a 5/16" (8 mm) hole at the four mounting hole locations you marked in Step 2. Later, you will insert four 1/4"-20 bolts through these holes to secure the antenna to the mounting surface.
4. Cut out the 1.5" (38 mm) cable access hole in the location you marked in Step 2. Smooth the edges of the hole to protect the antenna cable. (You may also apply anti-chafe material around the antenna cable to prevent abrasion.) Later, you will route the antenna cable through this hole and into the vessel.
5. Clean and dry the antenna mounting surface.

6. Peel off the paper backing from the supplied foam seal to expose the adhesive. Then press the foam seal down firmly onto the mounting surface, ensuring it is centered within the mounting bolt pattern and abuts the outside edge of the cable access hole, as shown in Figure 8.

Note: Apply the foam seal to the vessel mounting surface, not to the antenna’s baseplate. You will have difficulty connecting the antenna cable to the antenna if the foam seal is attached to the baseplate.

IMPORTANT!

Use only the KVH-supplied foam seal. Do not use any seals that may come with a third-party antenna mount, as they may block the drain holes in the baseplate.

Figure 8: Antenna Mounting Holes Layout

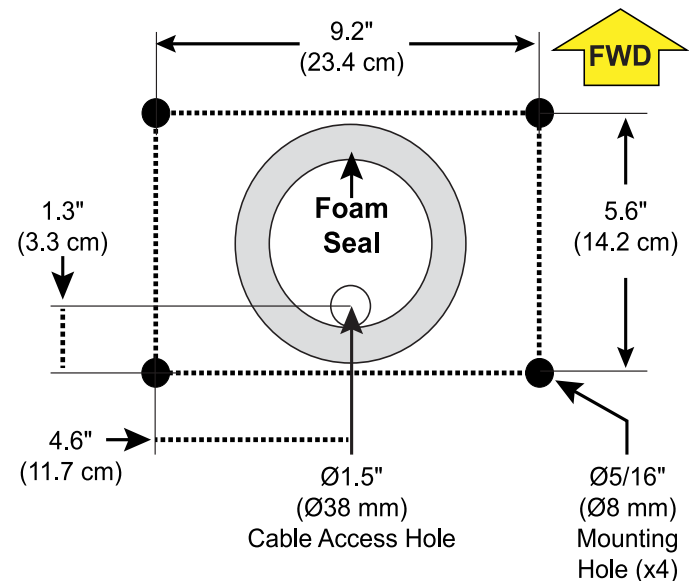

IMPORTANT!

The foam seal must be centered between the mounting bolt holes. The edge of the cable access hole will be close to the inner wall of the foam seal. (Unlike HTS antenna models, the center of the foam seal should **not** be aligned with the cable access hole, as the cable connector is offset from center.)

Prepare the Antenna Cable

You need to connect a single coax cable from the antenna to the BDU. KVH recommends using the supplied 50 ft (15 m) RG-58 cable. However, you may purchase a different cable for a longer run (see Figure 9 to determine type of cable and connectors required), or you may use a different cable of an acceptable type and length, as specified in “Approved Cable Types” on page 40 or the Cable Specs Wizard at www.kvh.com/TracNetcables. If you wish to reuse an existing cable from a previously installed antenna, it must be clean, free of rust or corrosion, and meet KVH specs for type and length.

IMPORTANT!

The integrity and reliability of the antenna cable is critically important. Make sure it is properly terminated, sealed against seawater and corrosion, strain-relieved, protected from abrasion, and free of stress.

The cable run must meet the following requirements:

- A low-quality, poorly terminated, or improperly installed cable is the most common cause of system problems. If the cable is modified for any reason, it must be terminated again with new connectors, using the proper tools, exactly to the manufacturer’s specifications. See “Terminating RG-58 Cable” on page 36 for instructions for the supplied cable. **Only KVH-authorized marine technicians should modify the antenna cable, if necessary.**
- Use of any cable type not approved by KVH will void the warranty.
- Make sure the center conductor pin at each end of the finished cable is free of burrs, as well as the correct length and diameter specified in Figure 9, to ensure proper engagement.
- Make sure there is no gap between the end of the cable jacket and the start of the connector.
- When determining cable lengths, don’t forget to account for service loops, 14" (36 cm) in diameter, at each end, and ensure you can maintain the minimum bend radius (which differs per cable) throughout the cable run.
- If you do not use an RG-58 or LMR-240 cable, you need to connect a pigtail cable between it and the BDU. You may also use a pigtail cable at the antenna end to maintain proper bend radius. These pigtail cables are available from KVH. See “Connecting Pigtail Cables to the Antenna Cable” on page 39.

Note: Cables purchased from KVH include the proper connectors.

Figure 9: New Cable Run Options (Available from KVH)

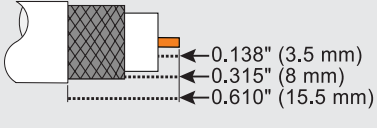
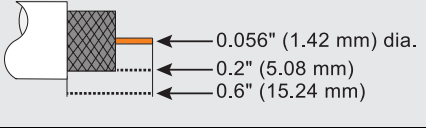
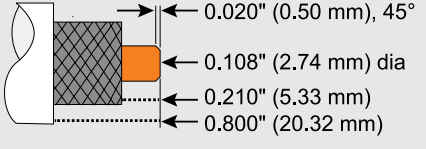
RG-58 (50Ω)	
Max. length	100 ft (30 m)
KVH part nos.	50 ft (15 m): 32-1439-0050 100 ft (30 m): 32-1439-0100
Connector	PE4156
Tools	Amphenol 47-10070 Crimp Tool, Steren 204-202 or Hanlong HT-312B Strip Tool (KVH part no. 72-0982)
Strip lengths	
LMR-240 (50Ω)	
Max. length	300 ft (90 m)
KVH part nos.	200 ft (60 m): 32-1453-0200 300 ft (90 m): 32-1453-0300
Connectors	EZ-240-TM-X
Tools	Times Microwave CT-240 Crimp Tool, CST-240 Strip Tool, DBT-U Debur Tool (KVH part no. 72-0949)
Strip lengths	
LMR-400 (50Ω)	
Max. length	500 ft (150 m)
KVH part no.	400 ft (120 m): 32-1441-0400
Connectors	EZ-400-TM-X
Tools	Times Microwave CT-400 Crimp Tool, CST-400 Strip Tool, DBT-U Debur Tool (KVH part no. 72-0950)
Strip lengths	

Wire the Antenna

Follow these steps to connect the antenna cable to the antenna's baseplate connector.

Route the Cable Belowdecks

1. Route the opposite end of the antenna cable belowdecks through the 1.5" (38 mm) cable access hole. Leave an adequate service loop, 14" (36 cm) in diameter, at the antenna location for serviceability.
2. Route the cable to the BDU location (you will connect it later). Always maintain the minimum bend radius in the cable.

Figure 10: Minimum Bend Radius

Cable Type	Min. Bend Radius
RG-58	2" (5.1 cm)
LMR-240	2.5" (6.4 cm)
LMR-400	4.5" (11.5 cm)

Connect the Cable to the Antenna

1. Clean and dry the antenna cable's connector and the connector on the bottom of the baseplate.

Figure 11: Antenna Baseplate Connector

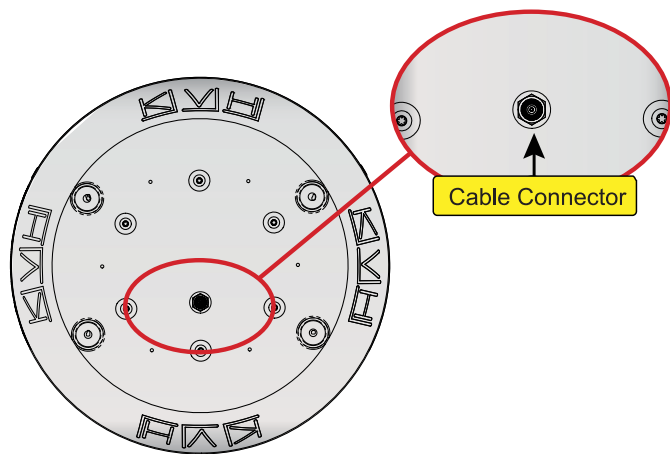

CAUTION

Be sure to observe the safe handling instructions in the Material Safety Data Sheet (MSDS) provided with the silicone grease.

2. Fill half of the inner body of the cable's male connector with the supplied silicone grease.
3. Connect and **SLOWLY** hand-tighten the cable to the antenna's connector, allowing the grease to diffuse and settle into the entire space within the connector.
4. Make sure the cable connector is hand-tightened all the way into the antenna's connector.
5. Seal the cable connection with self-vulcanizing tape or equivalent.

Figure 12: Connecting the Cable to the Antenna

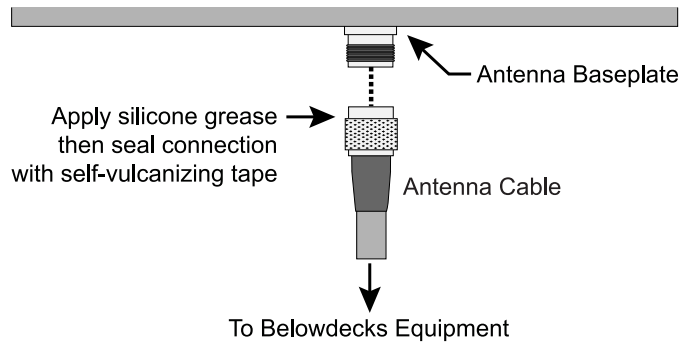

6. Secure the antenna cable near the antenna to relieve stress.
7. Weatherproof and seal the cable access hole.

Figure 13: Strain-relief (Finished Installation Example)

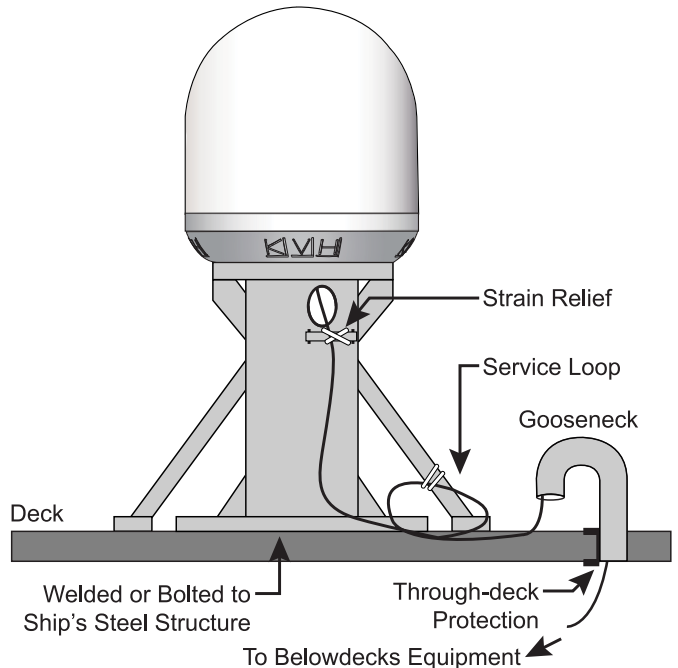

Mount the Antenna

Follow these steps to first remove the radome and foam shipping restraint, and then mount the antenna to the mounting surface.

1. Remove the three #10-32 screws securing the radome to the baseplate. Carefully lift the radome straight up until clear of the antenna assembly and set it aside in a safe place. If you keep the radome topside, secure it with a lanyard to prevent it from falling overboard.

Note: Due to the snug fit, some contact between the radome's sealing gasket and the antenna mechanism is normal during radome removal and installation.

Figure 14: Removing the Radome

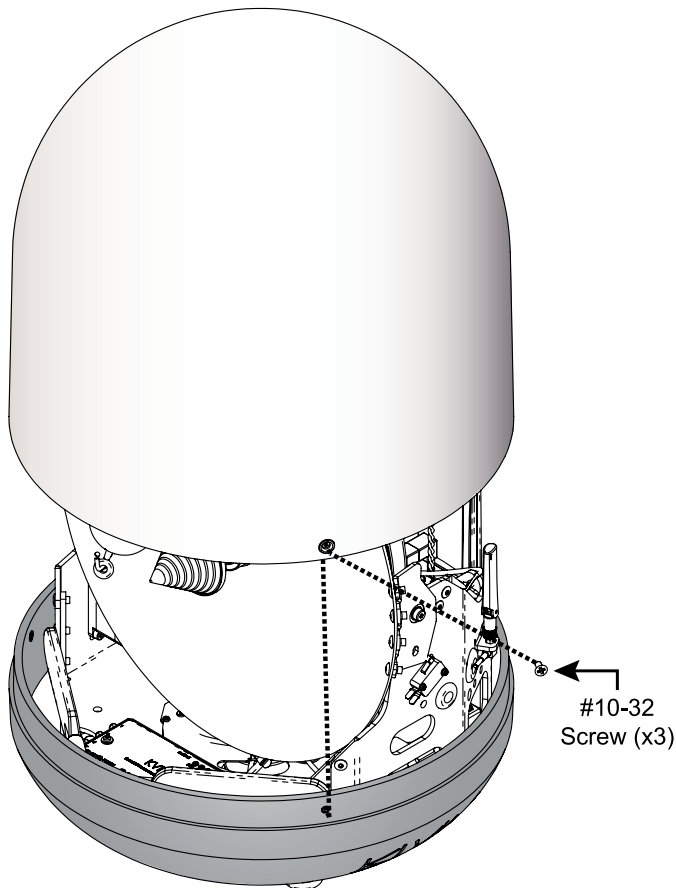

2. Remove the foam shipping restraint and save it for future use.



CAUTION

Once you have removed the restraint, handle the antenna carefully, as its internal assembly will rotate freely. Whenever you need to tilt the antenna, be sure to guard against having the internal assembly swinging around and potentially crushing your fingers.

Figure 15: Removing the Restraint

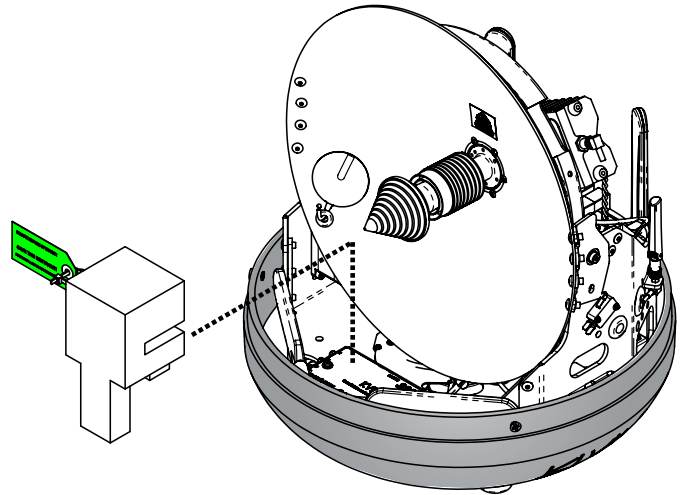

IMPORTANT!

Do not remove the tie-wraps securing the Wi-Fi and cellular antennas to the antenna frame. These are permanent and are not shipping restraints.

- Place the antenna baseplate over the holes drilled in the mounting surface and make sure the forward arrow inside the baseplate points toward the bow and is **parallel** to the vessel's centerline. The antenna's baseplate should rest squarely atop the foam seal.

Figure 16: Forward Arrow in Antenna Baseplate

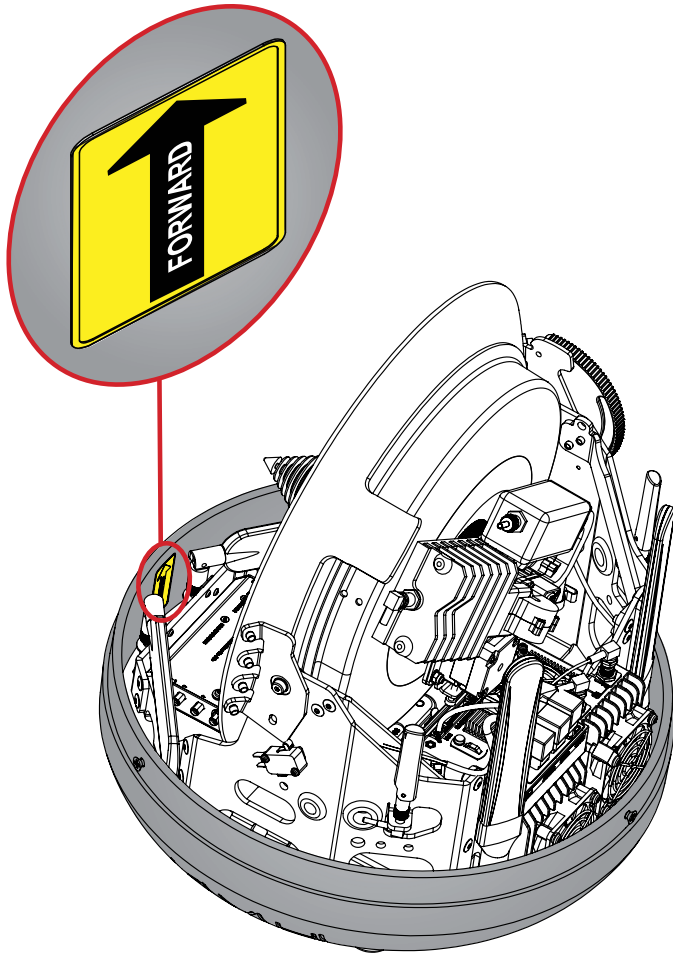

- Secure the mounting bolt to the mounting surface using a 1" diameter flat washer and a 1/4"-20 lock nut from below.
- You will need to rotate the antenna assembly slowly by hand to reveal each remaining mounting hole. Repeat Steps 5-6 at the remaining mounting holes, one at a time.
- Tighten all four bolts until the four rubber feet on the baseplate are bottomed against the mounting surface and the foam seal is fully compressed.

Figure 17: Mounting the Antenna (Side View)

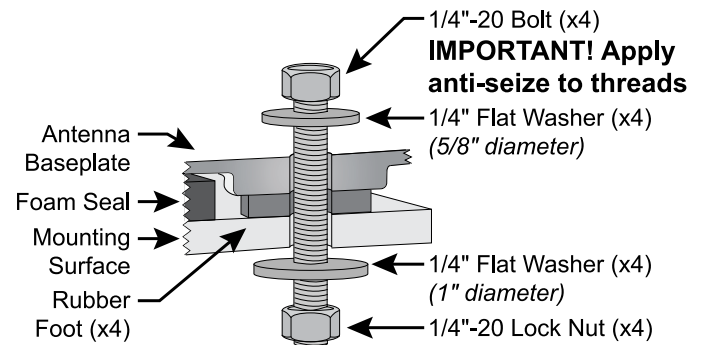

- Reinstall the radome onto the antenna. Secure in place with the three #10-32 screws you removed earlier (see [Figure 14 on page 11](#)).
- Install a protective plastic cap (*supplied in kit*) over each radome screw.

**CAUTION**

Be sure to observe the safe handling instructions in the Material Safety Data Sheet (MSDS) provided with the anti-seize lubricant.

- Apply a thin layer of the supplied anti-seize lubricant to the threads of the four 1/4"-20 bolts to prevent galling.
- At the baseplate mounting hole that you can see without rotating the antenna assembly, place a 5/8" diameter flat washer on a 1/4"-20 bolt and insert the bolt into the hole from above.

IMPORTANT!

Avoid using power tools. High installation speeds can damage the threads.

Mount the BDU (Hub+ Option)

Follow these steps to install the Hub+ inside the vessel. The Hub+ BDU can be mounted either in an equipment rack (preferred) or on a shelf.

Note: You may choose to wait to mount the BDU until after you have completed all system wiring.

Note: If you are installing a Hub BDU, skip to the next section.

Connect the Wi-Fi Antennas

First, connect the two supplied Wi-Fi antennas to the rear panel of the BDU.

Figure 18: Wi-Fi Antenna Connections

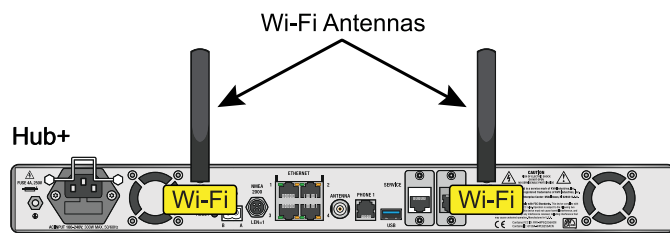

Mounting the Hub+ in a Rack

The Hub+ BDU can be mounted in a standard equipment rack. You will need 1U of available space.

1. Be sure to support the bottom of the BDU – don't rely on the front mounting brackets alone. The BDU weighs 8.3 lbs (3.7 kg). If the rack does not already provide underside support, install the "L" rails provided in the kit (see Figure 19). These rails can be nested for extended depth; connect them end-to-end using the supplied M5 screws and nuts (not shown in the figure).

Figure 19: "L" Rail Installation

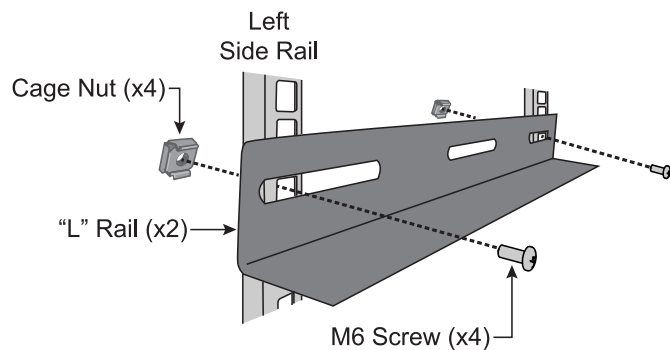

2. Attach the supplied strain-relief bracket to the back of the BDU using four supplied M3 screws.

Figure 20: Attaching the Strain-Relief Bracket

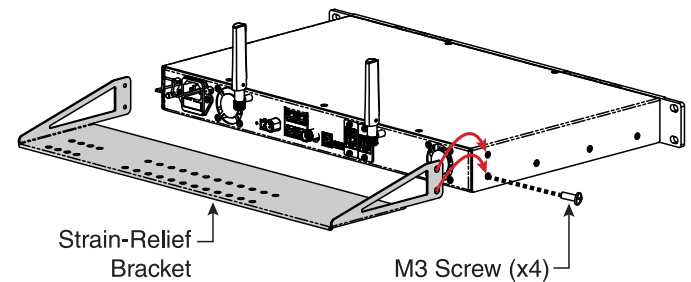

3. Insert the BDU into the rack and secure its front brackets to the rack with appropriate fasteners.

Figure 21: BDU Front Mounting Brackets

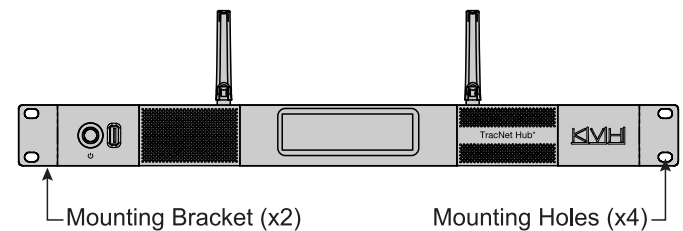

Mounting the Hub+ on a Shelf

1. Attach the supplied strain-relief bracket to the back of the BDU using the four supplied M3 screws (see Figure 20).
2. Secure the BDU in an adequate manner to prevent it from shifting while the vessel is in motion. Heavy-duty hook-and-loop tape is provided in the kit.

Note: If you choose not to use the supplied hook-and-loop tape, adhesive-backed rubber feet are also supplied in the kit to attach to the BDU's underside to protect the mounting surface.

Mount the BDU (Hub Option)

Follow these steps to install the Hub inside the vessel.

Note: Skip this section if you are installing a Hub+ BDU.

1. Before you begin, note the Hub's serial number provided on a label on the bottom of the unit. You might need this number later, as it is the default password for the built-in Wi-Fi.
2. Tape the mounting template in the location selected for the Hub. Punch holes at each of the two keyhole locations and at the mounting tab location.

Figure 22: Hub Mounting Template

Mounting Template

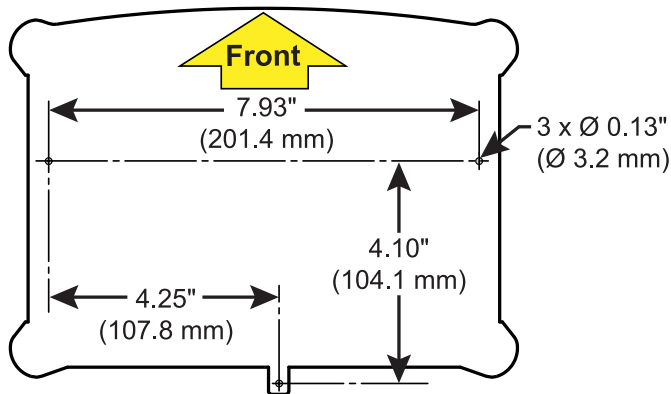

Bottom View of Hub

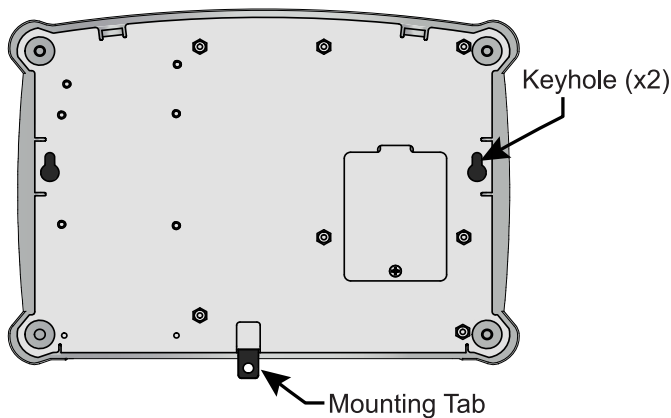

3. Remove the template.
4. Drill a 1/8" (3 mm) hole at the three hole locations you marked in step 2.
5. Install a #8 Phillips thread-forming screw partway into one of the keyhole holes leaving a small gap for hooking the Hub onto it. Use the thickness (2.5 mm) of the M10 washer (*supplied in kit*) as a gauge for the size gap to leave.
6. Repeat step 5 for the other keyhole.

7. Peel off the backing on the adhesive-backed washer (*supplied in kit*) and place it over the mounting tab hole.
8. Align the wide part of the Hub's keyholes, as shown in Figure 22, over the screws, then slide downward to secure the screws into the narrow part of the keyholes.
9. Press the rear mounting tab of the Hub onto the adhesive washer and install the third #8 Phillips thread-forming screw in the mounting tab hole.

IMPORTANT!

Make sure the Hub is securely mounted. Any movement of the Hub may put a strain on the antenna cable's connection.

Wire the BDU

Follow these steps to connect the antenna cable to the BDU.

IMPORTANT!

If you are using an RG-58 or LMR-240 cable, you may connect it directly to the BDU. If you are using any other type of cable, you must connect a pigtail cable between it and the BDU. See [“Connecting Pigtail Cables to the Antenna Cable”](#) on page 39.

1. Clean and dry the “Antenna” connector on the BDU.
2. Fill half of the inner body of the antenna cable’s male connector with the supplied silicone grease.
3. Connect and **SLOWLY** hand-tighten the cable to the BDU connector, allowing the grease to diffuse and settle into the entire space within the connector. **Do not use a tool or overtighten.**

IMPORTANT!

Do not connect anything other than the antenna cable to the “Antenna” connector. The BDU supplies voltage that will damage other devices.

4. Make sure the antenna cable will not get bent or twisted near the BDU’s connection, which can put additional stress on the connector. If the BDU is a Hub+, secure the cable to the strain-relief bracket.

Figure 23: Antenna Cable Connection

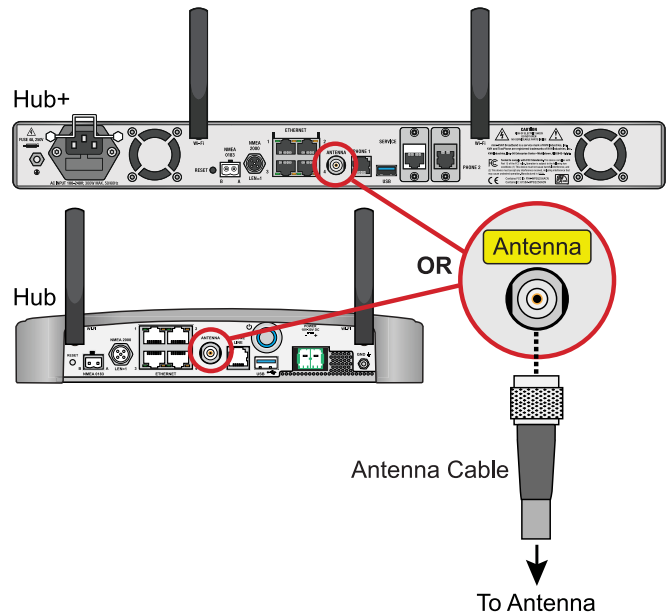

Connect an NMEA Talker

The antenna **requires** a vessel heading input from a customer-supplied NMEA 0183 or NMEA 2000 talker. Optionally, you can also provide a vessel position input to serve as a backup to the antenna's built-in GPS.

NMEA 0183

1. Connect the NMEA 0183 talker to the 2-position terminal strip connector (*supplied in kit*), as shown in Figure 26. Then plug the connector into the rear panel of the BDU.
2. Configure the NMEA device to transmit one or more of the supported NMEA 0183 messages at 4800 baud.
3. Make sure the data message(s) includes the checksum, identifiable by a *xx field at the end of the data sentence (e.g., \$HEHDT,123.4, T*1F). See [“Verifying the NMEA 0183 Message” on page 41](#) for details. Do not exceed a 10 Hz input rate.

Note: To supply both the required heading and the optional position to the BDU, you can either connect an NMEA 0183 talker that transmits both messages, or connect two devices using an NMEA data multiplexer, such as Actisense® model NDC-4.

Figure 24: Supported NMEA 0183 Messages

NMEA 0183 \$--XXX	Description
Heading Messages	
HDG	Heading, Deviation & Variation
HDM	Heading, Magnetic
HDT	Heading, True
OSD	Own Ship Data
THS	True Heading & Status
VHW	Water Speed and Heading
Position Message (Optional)	
RMC	Position (Optional)

NMEA 2000

1. Connect the BDU to the vessel's NMEA 2000 CAN network backbone via a "T" connector. Be sure to use a standard drop cable: 5-wire (4 conductors + shield) twisted pair with micro-C connectors.
2. Configure the NMEA device to transmit one or more of the supported NMEA 2000 messages.

Figure 25: Supported NMEA 2000 Messages

PGN	Description
Heading Messages	
127250	Vessel Heading
Position Message (Optional)	
129029	GNSS Position Data (Optional)

Figure 26: NMEA Wiring

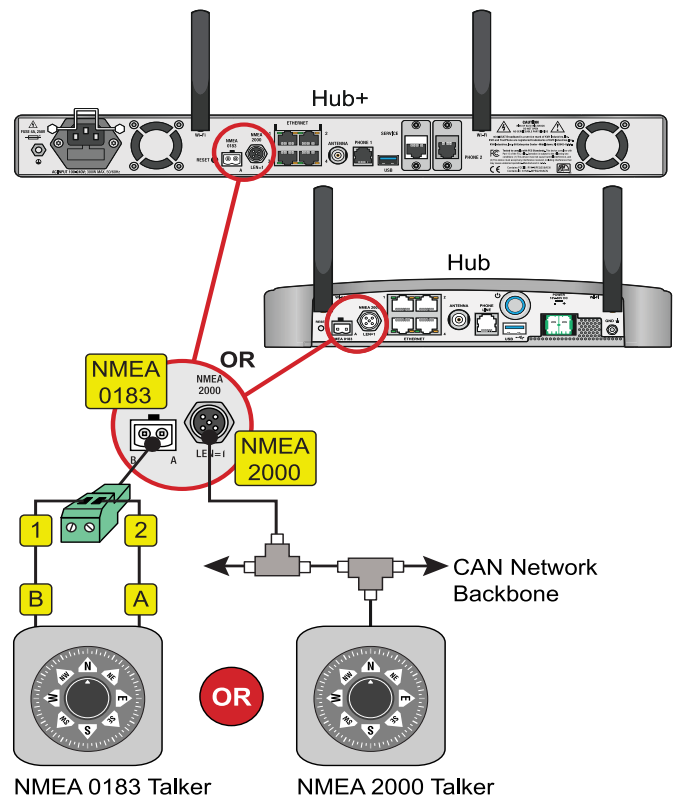

Connect Power (Hub+ Option)

Note: If you are installing a DC-powered Hub BDU, skip to the next section.

Before you begin, be sure that you understand the following important requirements:

AC Power Requirements

The TracNet system with Hub+ BDU is designed to run on 3-wire single-phase AC power (hot, neutral, and ground). Voltage between hot-neutral and hot-ground should each measure between 100-240 VAC.

Many large ships use two-phase, split-phase, or delta power instead (3 wires: hot, hot, and ground; no neutral). In this case, voltage between hot-hot measures the proper voltage (100-240 VAC); while hot-ground measures only half the voltage (50-120 VAC). Although the TracNet system with Hub+ BDU can operate on this type of power, the excess voltage present on the second phase will cause a small amount of current to leak onto ship's ground. This leakage current might be unacceptable on some vessels. So check with the customer or ship's electrician and get permission before you run the system on two-phase power. Also be sure to ground the system, as explained below.

If two-phase power is the only available power source onboard, and if leakage current is unacceptable, KVH recommends that you install a suitable isolation transformer to supply single-phase power to the antenna system and run a ground wire from the transformer to ship's ground. In addition, since ground fault protection devices cannot detect faults behind a transformer, you will also need to install a ground fault monitoring device between the isolation transformer and the antenna system if ground fault protection is required on the vessel.

Grounding Requirements

Proper grounding of the TracNet system to ship's ground is critically important, as it protects the equipment from electrostatic discharges (ESD). Failure to ground the chassis of the BDU risks damage to the antenna and electric shock.

Figure 27: AC Power Options

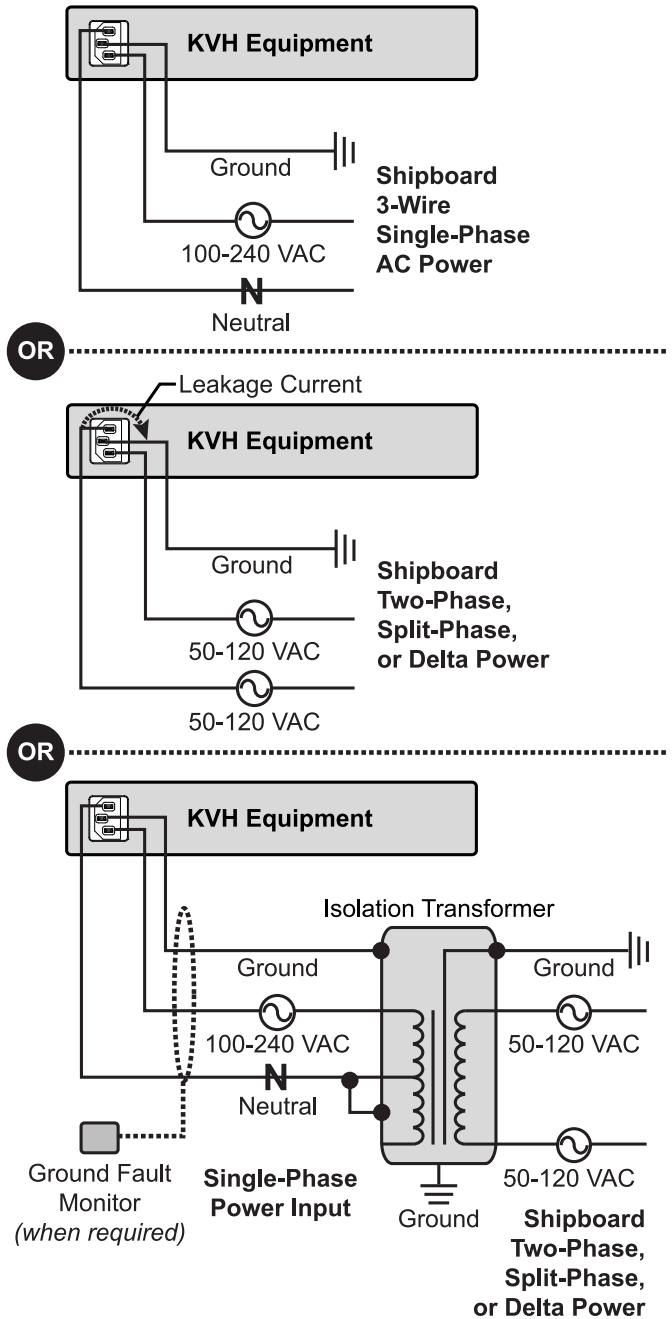

Connecting AC Power to the Hub+

Once you have read and understand the requirements on the previous page, follow these steps to connect AC power to the TracNet system.

1. Disconnect vessel power and be sure the vessel is properly grounded in accordance with marine standards.
2. Connect the supplied ground wire from the ground stud on the rear panel of the Hub+ BDU to ship's common ground (see Figure 28).



WARNING

Failure to ground the BDU properly to ship's ground will cause an unsafe floating ground condition, risking damage to the antenna and electric shock, potentially resulting in DEATH. In a floating ground condition, the difference between the equipment's chassis ground and the vessel's ground can measure well over 100 volts, when it normally should not exceed 2 volts. Therefore, always measure the difference in potential between chassis ground and ship's ground to make certain that there is no dangerous floating ground condition, even if the ground pin of the vessel's AC power plug appears to be intact.

3. Connect the supplied AC power cord to the Hub+ BDU.
 4. Plug the power cord into the vessel's 100-240 VAC supply.
- Note:** Consider installing an uninterruptible power supply (UPS) to avoid service interruptions during power outages and transitions to/from shore power.
5. Check for proper grounding by using a multimeter to measure the AC and DC voltages between the ground stud on the rear of the Hub+ BDU and ship's ground. The measured voltage should be less than 2 VAC and 2 VDC. **A higher voltage indicates a dangerous floating ground condition.**

6. Repeat the previous step with the Hub+ BDU powered on, looking for the same measured result.



WARNING

If you measure 2 volts or greater between the ground stud on the rear of the BDU and ship's ground, notify the ship's electrician or authorized vessel representative immediately. This is a dangerous condition. Do not touch the BDU rear panel or connect anything to it until the problem is fixed.

Figure 28: Hub+ AC Power Wiring

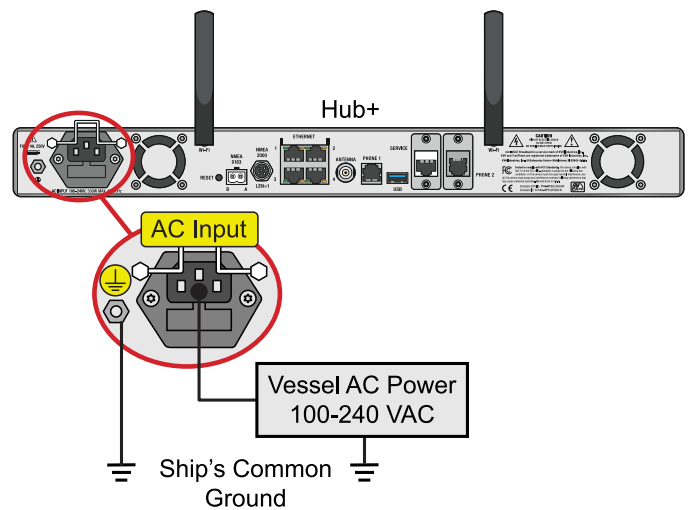

Connect Power (Hub Option)

Note: Skip this section if you are installing an AC-powered Hub+ BDU.

Grounding Requirements

Proper grounding of the TracNet system to ship's ground is mandatory for electromagnetic compatibility (EMC) and safety regulatory compliance. It protects the equipment from electrostatic discharges (ESD) and prevents interference with other electronic equipment. Follow these steps to ground the system.

1. Connect the hoop of the grounding wire (*supplied in kit*) to the "GND" screw on the rear panel of the Hub.
2. Connect the other end of the grounding wire to ship's common ground.



WARNING

Failure to ground the TracNet system properly to the vessel's ground will cause an unsafe floating ground condition, risking damage to the antenna and electric shock, potentially resulting in DEATH. In a floating ground condition, the difference between the equipment's chassis ground and the vessel's ground can measure well over 100 volts, when it normally should not exceed 2 volts. Therefore, always measure the difference in potential between chassis ground and the vessel's ground to make certain that there is no dangerous floating ground condition.

Connect DC Power to the Hub

IMPORTANT!

All power connections must be hard wired.

1. Before you begin, disconnect vessel power and be sure the vessel is properly grounded in accordance with marine standards.
2. Connect the supplied power cable wires to the supplied 2-position terminal strip connector:
 - Connect the black wire from "Vin-" on the terminal strip connector to DC Return.
 - Connect the red wire from "Vin+" on the terminal strip connector to the vessel's 12 or 24 VDC (160 W max.) power source.

3. Insert a fuse (*supplied in kit*) into the in-line fuse holder. If vessel power supplies 12 volts, use the blue 15A fuse. If it supplies 24 volts, use the brown 5A fuse.
4. Connect the terminal strip connector to the Hub's Power connector.
5. Check for proper grounding by using a multimeter to measure the AC and DC voltages between the ground stud on the rear of the Hub and ship's ground. The measured voltage should be less than 2 VAC and 2 VDC.
6. Repeat step 5 with the Hub powered on, looking for the same measured result.



WARNING

If you measure 2 volts or greater between the ground stud on the rear of the Hub and ship's ground, notify the ship's electrician or authorized vessel representative immediately. This is a dangerous condition. Do not touch the Hub rear panel or connect anything to it until the problem is fixed.

Figure 29: Hub DC Power Wiring

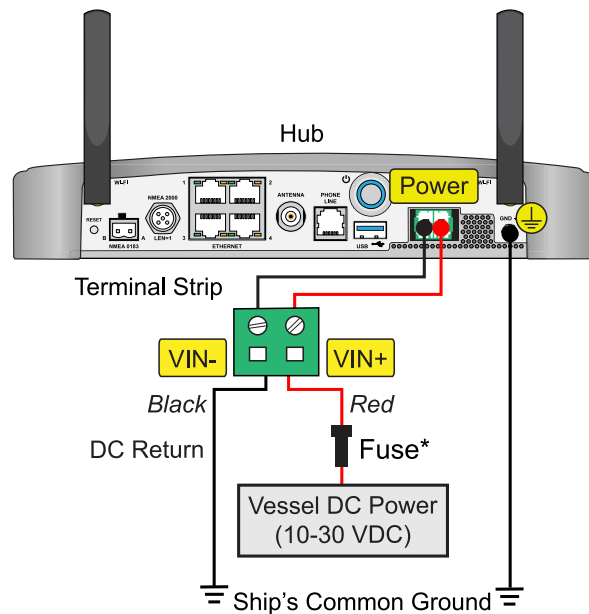

*if vessel power supplies 12 volts, use blue 15A fuse;
if vessel power supplies 24 volts, use brown 5A fuse

Turn On the System

Follow these steps to turn on the system.

1. Ensure the antenna has a clear, unobstructed view of the sky.
2. Apply vessel power to the TracNet system.
3. Press the power button on the front of the Hub+ BDU or on the back of the Hub BDU. The button's light should illuminate blue.

Figure 30: BDU Power Button

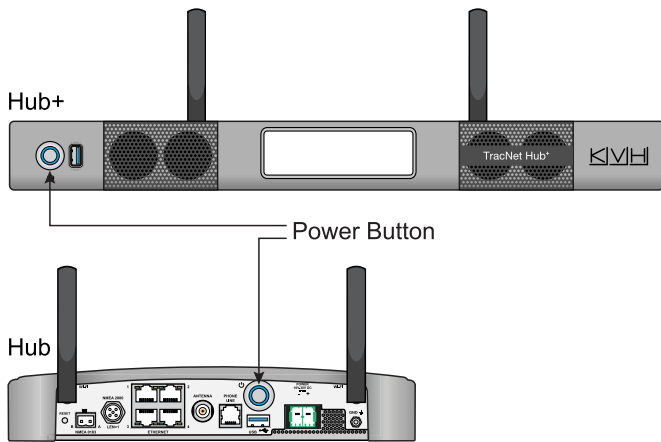

IMPORTANT!

During startup, the BDU checks the software installed in the antenna and updates it if necessary to match its currently installed version. Do not turn off the system for at least 15 minutes to allow any updates to complete.

4. **(Hub+ Only)** At the BDU's front panel touchscreen, go to the VSAT page (2) and monitor the antenna status. Within two minutes, the antenna should complete initialization and start searching for the satellite. Also make sure no errors are reported in the header (see example in Figure 32).

Figure 31: VSAT Status Page on Hub+ Front Panel

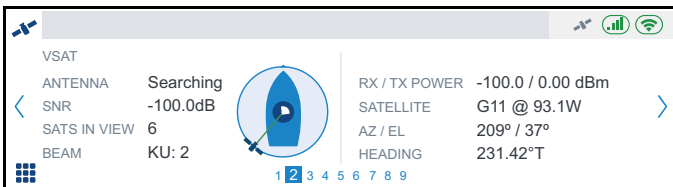
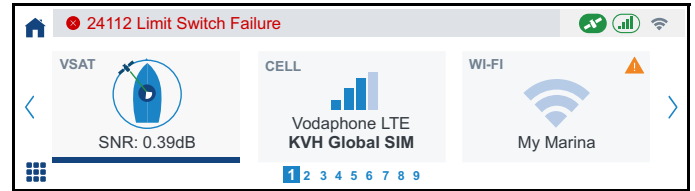
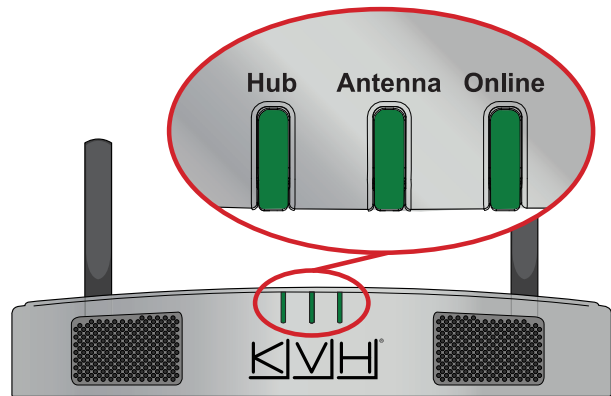

Figure 32: Error Message on Hub+ Front Panel (Example)



5. **(Hub Only)** A few minutes after initialization, make sure the "Hub" and "Antenna" lights on the BDU are lit green, indicating normal operation.

Figure 33: Hub Status Lights



Configure the System

Follow the steps on the next few pages to access the setup wizard and configure the system for use.

Access the Setup Wizard

Follow the steps for either option below to access the setup wizard.

Option 1: Using the Wireless Connection

1. Select the **KVHVSAT<last 3 digits of BDU serial no.>** network from your mobile device's Wi-Fi settings to connect to the BDU.
2. Enter the default password: **<full 9-digit BDU serial no.>**.
3. Start the web browser and enter **https://kvhonboard.com**.

Note: If the setup wizard is not displayed, try entering <https://192.168.5.1>, which is the default IP address. You might need to bypass a warning from your browser to proceed to the site.

Figure 34: Wi-Fi Connection

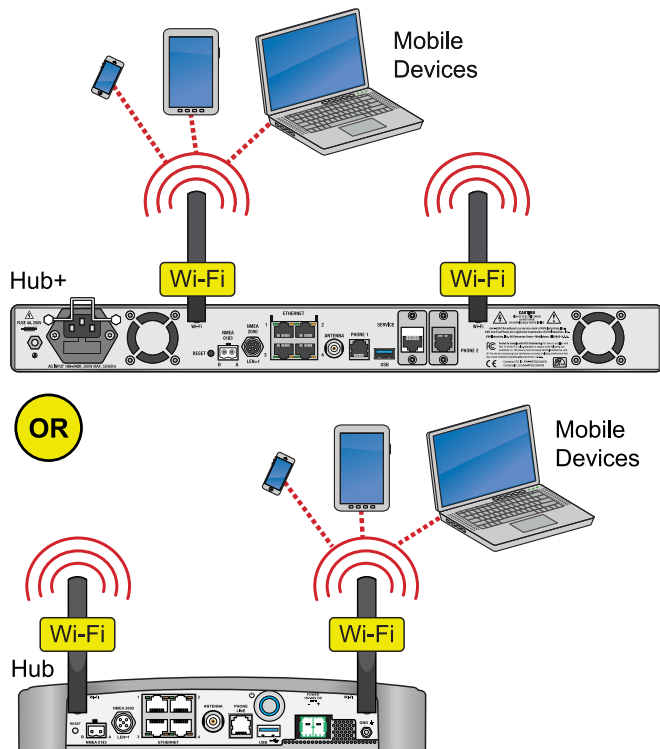

Option 2: Using the Ethernet Connection

1. Connect a laptop PC configured for DHCP directly to Ethernet port 1 on the BDU.
2. Start the web browser and enter **https://kvhonboard.com**.

Note: If the setup wizard is not displayed, try entering <https://192.168.5.1>, which is the default IP address. You might need to bypass a warning from your browser to proceed to the site.

Figure 35: Wired Ethernet Connection

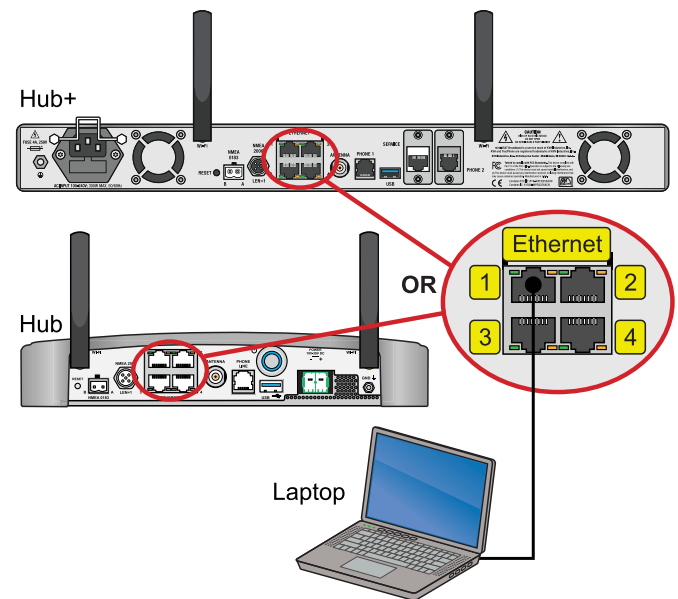

Run the Setup Wizard

The Setup Wizard appears upon initial startup to step you through system configuration. Through the setup wizard, you will:

- Enter administrator and guest account passwords
- Enter the vessel name
- Enter a phone line name
- Configure LAN and built-in Wi-Fi settings (optional)
- Set the network configuration of the BDU's Ethernet ports
- Configure WAN settings (optional)

Follow the steps in the following sections to set up the system.

Figure 36: Wizard Welcome Screen

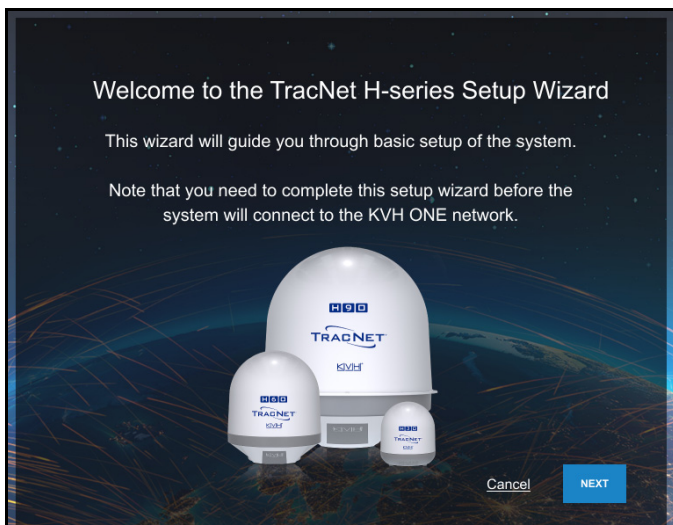

Note: After setup is complete, you must log into the web interface as an administrator to make further changes to the system settings.

Assign an Administrator Password

At the first page of the wizard, you must set the following:

- **PASSWORD:** Enter and then re-enter an administrator password of the customer's choice
- **VESSEL NAME:** Enter the vessel name
- **PHONE LINE 1 NAME:** Enter a name for the phone line

Note: The case-sensitive password must be between 8 and 64 characters in length, with at least one letter, one number, and a special character.

Figure 37: Assigning the Administrator Password

Assign Administrator Account Information

The Administrator account has read/write access for configuration changes to the terminal.

User Name `admin`

Password*

Confirm Password*

Vessel Name*

Phone Line 1 Name*

[Cancel](#)

When you are done, select **Next**.

Assign a Guest Account Password (Optional)

At the second page of the wizard, you can set the following:

- **PASSWORD:** Enter and then re-enter a guest account password of the customer's choice

Note: The case-sensitive password must be between 8 and 64 characters in length, with at least one letter, one number, and a special character.

Figure 38: Assigning the Guest Password

Assign **Guest Account Password** (optional)

The Guest account allows read-only access to terminal status and configurations.

User Name *guest*

Password*

Confirm Password*

BACK NEXT

When you are done, select **Next**.

Configure LAN Settings (Optional)

At the third page of the wizard, you can make any necessary changes to the following LAN settings:

IMPORTANT!

The default LAN settings work well for most installations. Do not change these settings unless absolutely necessary, such as to avoid conflicts with an existing onboard network.

- **IP ADDRESS:** Change the default IP address
- **SUBNET MASK:** Change the default subnet mask
- **DHCP MODE:** Set to "ON" or "OFF" (If DHCP is on, select a **DHCP START** and **DHCP END** range)

Note: By default, the LAN has a gateway of 192.168.5.1 and assigns IP addresses in the 192.168.5.50-150 range.

Figure 39: Configuring LAN Settings

Configure **LAN Settings** (optional)

Modify IP settings only if necessary to avoid conflicts with an existing onboard network. Set a unique password for Wi-Fi access to the terminal.

High-Speed Channel

IP Address

192.168.5.1

Subnet Mask

255.255.255.0

DHCP Mode ON OFF

DHCP Start:

192.168.5.50

DHCP End:

192.168.5.150

Configure Built-In Wi-Fi Settings

With Wi-Fi enabled, vessel devices can connect to the BDU via its built-in wireless access point (WAP). At the third page of the wizard, you can make changes to the following built-in Wi-Fi settings:

IMPORTANT!

Establishing a wireless connection onboard a steel vessel might require a special external WAP and advanced networking expertise.

- **BUILT-IN WI-FI:** Set to “ON” or “OFF”

IMPORTANT!

For the customer’s protection, an open Wi-Fi without security protocols is not permitted. Setting Built-in Wi-Fi to “On” will simultaneously activate WPA-PSK security and require creating a Wi-Fi password.

- **SSID (WI-FI NETWORK NAME):** Enter a unique name for the Wi-Fi network
- **BAND:** Select either 2.4 GHz or 5 GHz
- **CHANNEL:** Select either Auto or 1-11 channels
- **PASSWORD:** Change the password (at least 8 characters)

Figure 40: Configuring the Built-in Wi-Fi Settings

When you are done, select **Next**.

Set the Port Configuration

At the fourth page, you can change the LAN configuration of the BDU’s Ethernet ports, if necessary.

Option	Configuration
All HS (default)	Ports 1-4, Wi-Fi: High-speed LAN
HS + Backup + Alternate	Ports 1-2, Wi-Fi: High-speed LAN Port 3: Backup WAN Port 4: Alternate WAN

If you would like to connect an external gateway to the TracNet system to serve as either an alternate or backup connection (see [“Add Backup or Alternate WAN Connection \(Optional\)” on page 34](#)), select “HS user LAN, Plus Backup and Alternate WAN.” Otherwise, keep the default “All High-speed (HS)” setting.

Figure 41: Setting the Port Configuration

Configure WAN Settings

With its hybrid network capability, the TracNet system can automatically switch to an available cellular or shore-based Wi-Fi network for Internet connectivity. At the fifth page of the wizard, select the shore Wi-Fi network or networks that the TracNet system should use.

The wizard lists any Wi-Fi networks it has detected broadcasting in the area. You may select one or more networks from this list and enter associated password(s).

To add a network not shown in the list, select **Advanced Wi-Fi Settings**. Select “+”. Then enter the network name, security protocol, and password.

Figure 42: Configuring WAN Settings

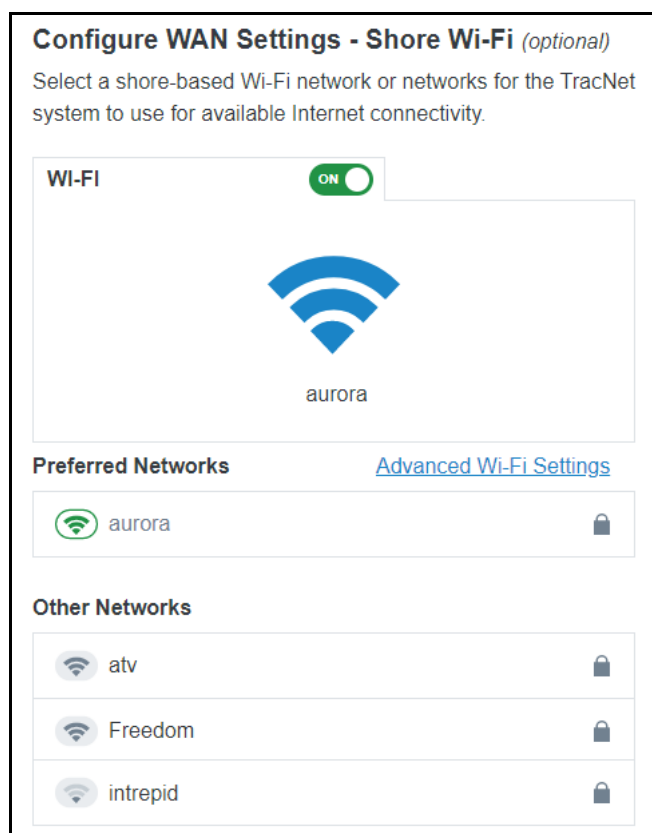

When you are done, select **Next**. At the final screen, select **Exit Wizard**. Then wait a few minutes for the system to apply the new settings. When the login page appears, enter the admin credentials to access the web interface.

Note: If you changed the LAN settings and the login page does not appear after a few minutes, try entering in your browser the correct IP address for the port or Wi-Fi that you are using to connect. You can also try renewing the DHCP lease on your device.

Update the System Software

Follow these steps to check the currently installed software versions and install new software, if necessary.

Note: This procedure explains how to update the software using the web interface and your laptop computer. However, you can also update the software using the KVH Connect mobile app. Details are available in the Help.

1. At the web interface, go to the **Software Updates** page. Note the displayed software versions for antenna and BDU.

Figure 43: Software Updates Page

Software Updates
Last Update: 2023-04-05 04:53:23 UTC ⓘ

Update Software from This Computer
To update the system's software using a file located on this computer, select Choose File.

CHOOSE FILE

Software Update Status

All Components Up-to-date

LAST CHECK FOR UPDATES: 2023-04-05 04:53:23

CHECK NOW

Software Versions

BDU	2.4.0-rc.7
BDU-IO	2.4.0-rc.7
ANTENNA	2.4.0-rc.7
VSAT MODEM	3.3.2.2-7713
TCM	2.4.0-rc.6
TCM SIM PROCESSOR	2.3.0

2. If the reported software versions are earlier than the latest version you downloaded from the KVH Partner Portal, select **CHOOSE FILE**.

Note: This single software update file applies to both the antenna and the BDU (i.e., Hub+ or Hub).

3. Select the software update file you saved on your laptop. Be sure it is the correct version of H-series software for your system's BDU type: **AC-BDU** for Hub+, **DC-BDU** for Hub.

IMPORTANT!

Once the file is uploaded, you will lose your connection to the web interface (and the built-in Wi-Fi) temporarily. If you would like to view the status of the update, you may log back into the web interface after a couple minutes, return to the Software Updates page, and refresh your browser window to view the current state in the Software Update Status box. The software update progress is also shown on the Hub+ BDU's front panel.

4. Wait for the software update to complete. **Do not turn off power to the system during this update.**
5. Reconnect to the web interface and verify that the Software Updates page is now displaying the latest version.

No-Transmit Zones (Optional)

To prevent exposure to RF energy (see [page 1](#) for an illustration of the hazard area), you can configure up to two no-transmit zones for areas where crew and/or passengers frequent. The system will disable the transmitter whenever the antenna is pointing within one of these zones.

Figure 44: Example of a No-Transmit Zone

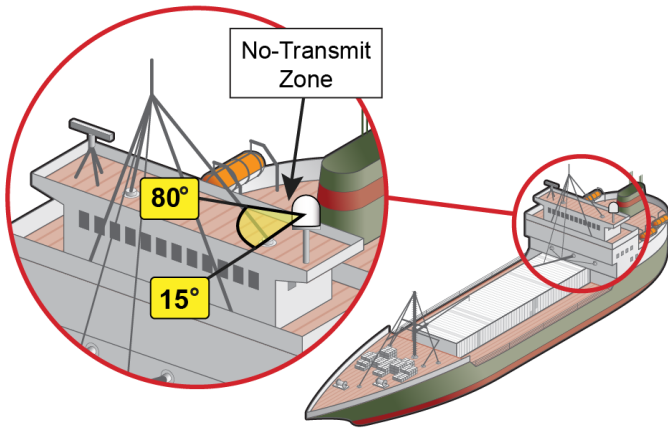

Follow these steps to set up a no-transmit zone.

1. Determine the necessary azimuth range for the no-transmit zone(s). You will need to enter, in clockwise order, beginning and ending azimuths that define the outer boundaries of the zone(s) **relative to the antenna's forward arrow**, which should be pointing toward the bow.

Figure 45: Azimuth Relative to Antenna's Forward Arrow

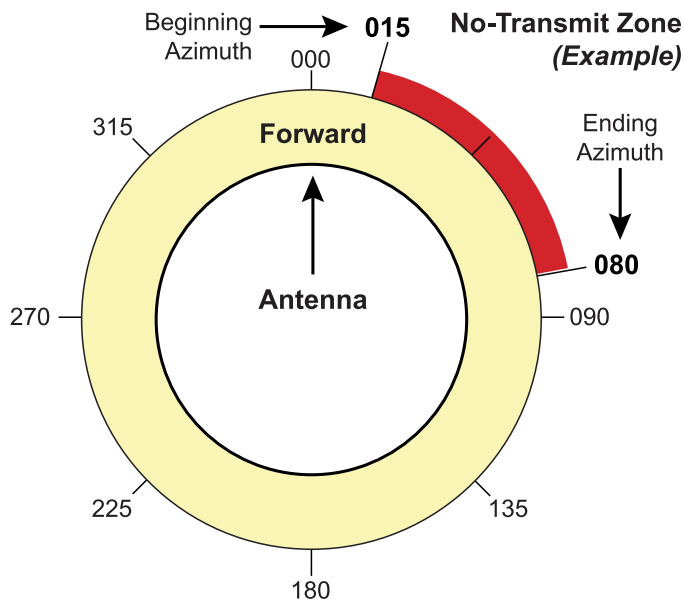

Note: Each no-transmit zone must span at least 5°. Therefore, be sure to set the beginning and ending azimuths at least 5° apart.

2. At the web interface, select the **No-Transmit Zones** page. Then select **Edit**.
3. Select **Enforce Zones**.

Figure 46: No-Transmit Zones Page of Web Interface

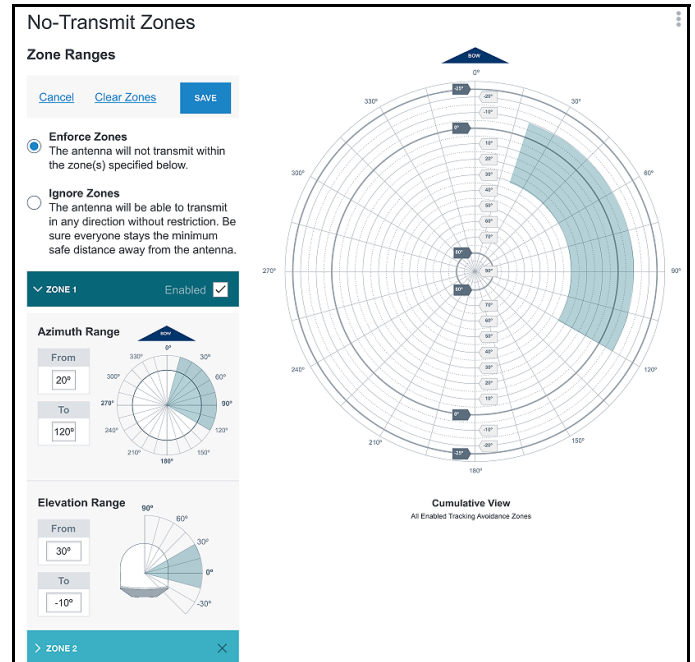

4. Enter the azimuth range for Zone 1.
5. Enter the azimuth range for Zone 2, if required.
6. Select **Save**.

Note: The elevation range is automatically set to the antenna's operating range.

Test the System

1. Ensure the antenna has a clear, unobstructed view of the sky.
2. At the web interface, go to the Terminal Home page and select the **VSAT Only** network mode from the Network Selection drop-down menu.
3. Verify that the antenna is tracking the VSAT satellite and the system is online.

Figure 47: Good VSAT WAN Connection Indicated in Web Interface

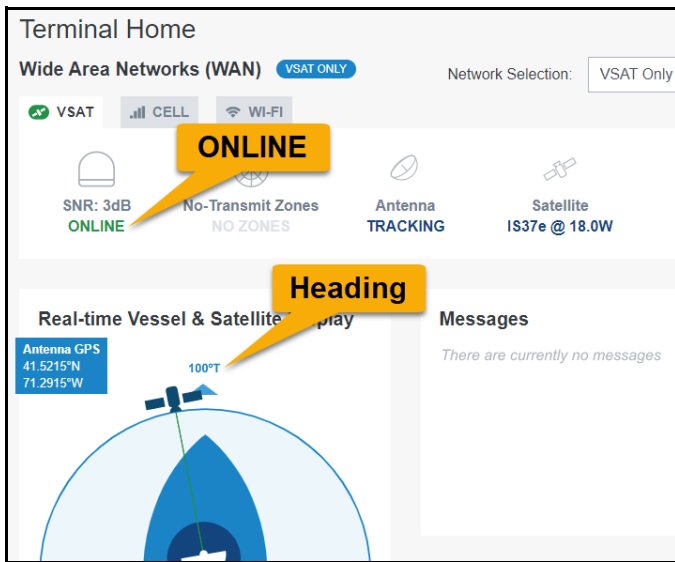

4. Make sure the vessel's heading is displayed in the Real-time Vessel & Satellite Display. If not, check the wiring to the NMEA device.
5. Enter the following address in a new web browser tab or window: <http://test.minivsat.net>. Verify that a Welcome screen appears, indicating good communications between the antenna system and the land-based hub.
6. If the customer activated the TracNet system for KVH ONE™ VSAT service, open a new browser tab and try to access the Internet (such as google.com) over the VSAT connection.
7. Turn on all other electronic equipment above deck within the proximity of the antenna, if possible. Verify that both the KVH system and the electronic equipment continues to operate without any degradation in performance.

8. If the customer activated the TracNet system for KVH global cellular service, select the Cell tab. If there is cellular service in your area, select the **Cell Only** network mode. Then open a new browser tab and try to access the Internet (such as google.com) over the cellular connection.

Figure 48: Cell WAN Status

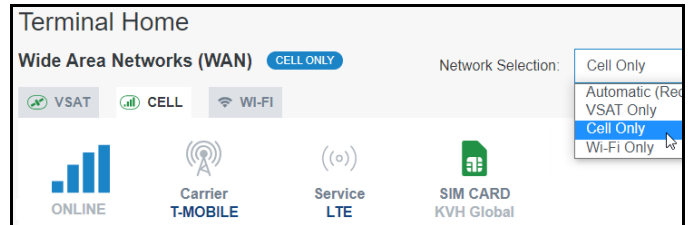

9. If you set up the system for a shore Wi-Fi network, select the Wi-Fi tab. If there is adequate Wi-Fi service in your area, select the **Wi-Fi Only** network mode. Then open a new browser tab and try to access the Internet (such as google.com) over shore Wi-Fi.

Figure 49: Wi-Fi WAN Status

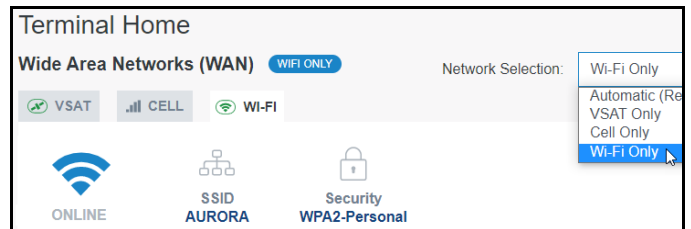

10. Return the system to **Automatic** network mode.
11. Fill out the Installation Checklist (provided in the Customer Welcome Kit) and return it to KVH. Refer to the instructions on the form.

IMPORTANT!

Submission of the Installation Checklist is required to certify the quality of the installation.

Connect Vessel Network Devices

The BDU includes four Ethernet ports and a built-in wireless access point (WAP). Unless you changed the port configuration at the Setup Wizard, Ethernet ports 1 through 4 and the built-in WAP provide high-speed Internet access. Follow these additional steps to set up the network.

1. Connect the computers and/or other network devices to the BDU. You might wish to add an external WAP (or Wi-Fi router configured for bridge mode) to supplement the built-in Wi-Fi access.

Figure 50: Vessel Network Example (Hub+ Shown)

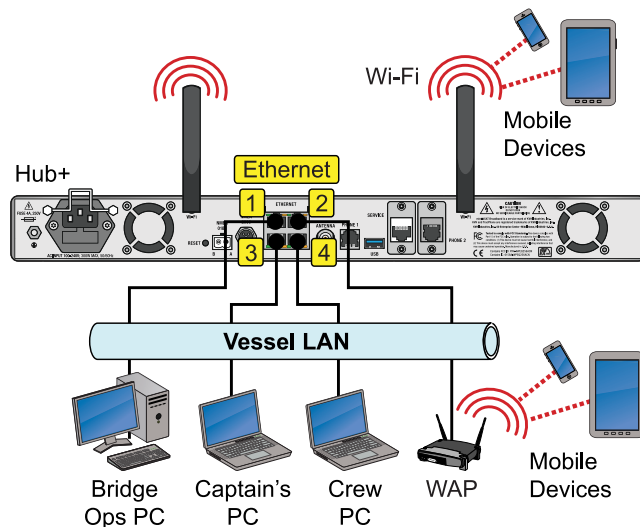

2. Devices connected to the BDU (via Ethernet cables or Wi-Fi) will receive IP addresses from the BDU via DHCP. The BDU serves as a router.

Note: Unless you changed the LAN settings at the Setup Wizard, the LAN has a gateway of 192.168.5.1 and assigns IP addresses in the 192.168.5.50-150 range.

Global Static IP

Global Static IP service allows you to set up a network device with an IP address that can be accessed directly from the Internet. It does not receive an IP address from the BDU. If you require Global Static IP Service, follow these additional steps to configure the network.

IMPORTANT!

A static IP address should only be assigned to a secure device, such as a firewall router.

1. Fill out the request form at www.kvh.com/staticip. In addition, the system must be activated for KVH ONE service, and it must remain online until KVH configures the system over the air.
2. Connect the static IP device(s) to the BDU.
3. You will need to configure the devices' TCP/IP properties according to the instructions KVH will provide in an email upon fulfilling the static IP request.

Connect the Vessel Phone

Using the supplied RJ-11 cable, connect the analog (not digital) phone or PABX to the “Phone 1” jack on the Hub+ BDU or “Phone Line” jack on the Hub BDU.

Figure 51: Connecting the Vessel Phone (Example)

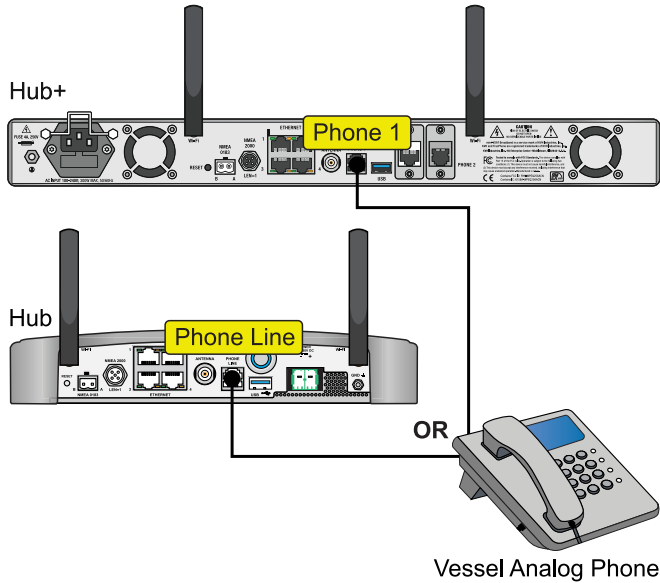

Strain-relief

Once all cables are connected to the BDU, secure them near the back of the BDU to relieve stress, while leaving enough slack for easy serviceability. If the BDU is a Hub+, use tie-wraps to secure the cables to its strain-relief bracket (see Figure 20 on page 13).

Add Third-party SIM (Optional)

As an alternative to the KVH Global cellular service, the TracNet system supports the use of a customer-supplied SIM for cellular WAN connectivity. Follow these steps to activate the SIM card and the SIM card slot in the BDU and install the third-party SIM card (*standard size only: 15 mm x 25 mm*).

IMPORTANT!

The BDU cannot accept a locked SIM card. Be sure the SIM card is unlocked.

Activate SIM Card for TracNet Use

The customer-supplied third-party SIM card must be activated by its cell carrier to pair it with the TracNet antenna's Terrestrial Communications Module (TCM). The customer may need to provide the TCM's unique IMEI number to the cell carrier to complete the activation process. You can find the TCM's cell IMEI number on the Support page of the web interface.

IMPORTANT!

Give the TCM cell IMEI number to the customer and make sure they understand that they need to activate the SIM card for this device. Note that not all cell carriers currently support the TCM on their network.

Figure 52: TCM Cell IMEI Number on Support Page (Example)

System Details	
Software Versions	
BDU	2.4.0-rc.7
BDU-IO	2.4.0-rc.7
ANTENNA	2.4.0-rc.7
VSAT MODEM	3.3.2.2-7713
MTA	3.1.2 (Build: 5897P)
TCM	2.4.0-rc.6
TCM SIM PROCESSOR	2.3.0
TCM CELL MODEM	RM502QAEAAAR11A02M 4G
Hardware Information	
BDU TYPE	TracNet Hub+
BDU S/N	999999999
ANTENNA S/N	999999999
VSAT MODEM S/N	18709
VSAT MODEM DID	637552755
MTA MAC ADDRESS	9CA9CF44EADE
TCM CELL IMEI	867826050040500

Note: The TCM integrates both a cellular modem and a Wi-Fi modem and connects to multiple cellular and Wi-Fi antennas inside the antenna dome.

Activate the BDU SIM Card Slot

1. At the web interface, go to the WAN Settings page and select the Cell tab.
2. Click the edit (pencil) button next to the desired BDU SIM card slot (1 or 2), where you will be inserting the third-party SIM card. Enter a friendly name for this cellular service and enter its APN (Access Point Name). *The APN is available from the cell carrier. The SIM card cannot be used without a valid APN.*

Figure 53: BDU SIM Slot Configuration

3. Select **Save**.
4. Select the new SIM that you just configured from the Active SIM drop-down menu.
5. At the pop-up window, select **Activate SIM & Power Off**.

Install the SIM Card

1. Make sure the BDU is fully powered off.
2. Remove the M3 Phillips screw securing the SIM card access cover from the bottom of the BDU chassis. Set the screw and cover aside.

Figure 54: Removing the SIM Card Access Cover

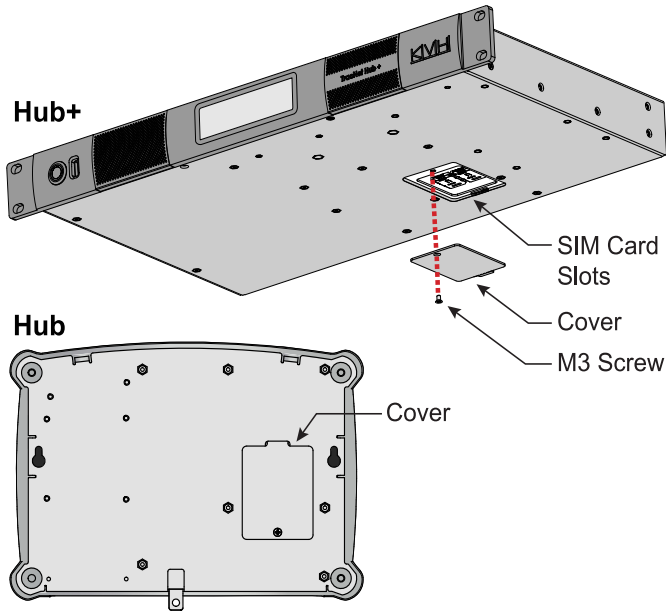

3. Identify the SIM card slot that you configured in the previous section. Then perform the following steps for that slot. *(The photos assume SIM card slot 1 is active.)*

Figure 55: BDU SIM Card Slots



4. Gently slide back the protective metal screen from the SIM card tray to unlock it. Then tilt it back at its hinge.

Figure 56: Opening the SIM Card Screen

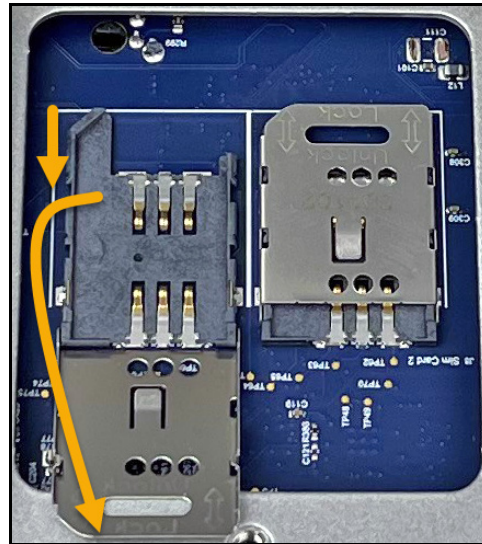

IMPORTANT!

Be very careful not to lose the SIM card or drop any debris inside the BDU chassis. Also do not insert any metal tools inside the SIM card access cavity to prevent damage to the circuit board.

5. Carefully place the third-party SIM card into the tray with its metallic contacts facing down to mate with the spring contacts in the tray.

Figure 57: SIM Card Placed in Tray

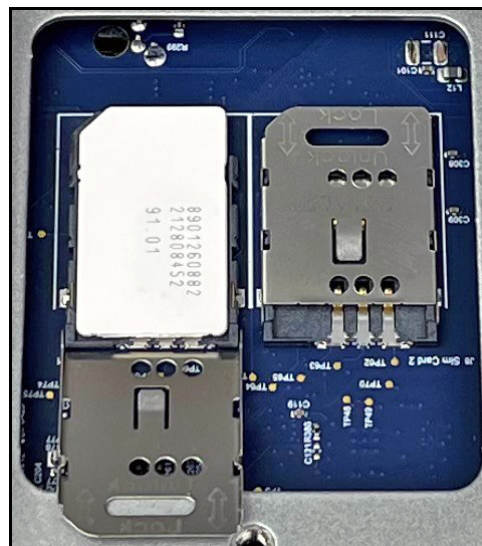

- While holding the SIM card in position against the tray's contacts, close the metal screen over the SIM card then gently slide up the screen to secure it in place. Be sure you hear a click, indicating it is locked.

Figure 58: SIM Card Installed, Screen Locked in Place



- Reattach the cover to the bottom of the BDU chassis.
- Power on the BDU. Wait a few minutes for initialization.

Check SIM Card Information

At the web interface, return to the WAN Settings - Cell page. Verify that the SIM card's ICCID, IMSI, and home network are shown in the details for the configured BDU SIM. Also verify that the TracNet system is now connected to the cell service, assuming the SIM is activated and you are located within its cell service coverage area.

Figure 59: SIM Card Data Shown on Web Interface

Active SIM	BDU SIM Slot 1	?
Configure SIM Slots		
	NAME	KVH Global SIM
	APN	kvh.vrs.vodafone.nl
1	NAME	BDU SIM Slot 1
	APN	apn.apn.vodafone.nl
	ICCID	123456789000001123
	IMSI	1234 5678 9000 001 123
	HOME NETWORK	NetworkName
2	NAME	BDU SIM Slot 2
	APN	APN Needed for Activation

Note: If you want to revert the system to use the KVH Global SIM, select it as the active SIM. The user can change the active SIM at any time.

Add Backup or Alternate WAN Connection (Optional)

You can add an external gateway to the TracNet system to serve as either a backup or alternate data connection.

Backup WAN

In automatic mode, the TracNet system will use the backup connection only when no other gateway is available. A common choice of backup connection is the Iridium Certus service, as it provides pole-to-pole coverage.

Note: Antenna systems and airtime plans for Iridium Certus service are available for purchase from KVH.

Alternate WAN

In automatic mode, the TracNet system will use the alternate connection whenever it is available – it will be the preferred connection. An example of an alternate WAN might be an Ethernet connection to the marina’s Internet service or the customer’s cellular hotspot.

Note: The TracNet system can also be configured to use a Starlink flat high-performance antenna system as the Alternate WAN connection. Refer to the separate Starlink KVH Configuration Instructions available on the KVH website.

Adding the Backup or Alternate WAN

Follow these steps to set up a Backup or Alternate WAN connection.

1. At the web interface, go to the Port Configurations page and apply the “HS user LAN, Plus Backup and Alternate WAN” configuration.
2. Using an Ethernet cable, connect the backup or alternate device’s LAN to the designated port on the TracNet system’s BDU, as defined by the selected port configuration (see “Set the Port Configuration” on page 24).
3. Change the gateway IP address on the backup or alternate WAN device to the appropriate address below. Refer to the device’s user documentation for details.

WAN Option	Gateway IP Address
Backup	198.19.56.1
Alternate	198.19.55.1

Figure 60: Alternate and/or Backup WAN Connections (Example)

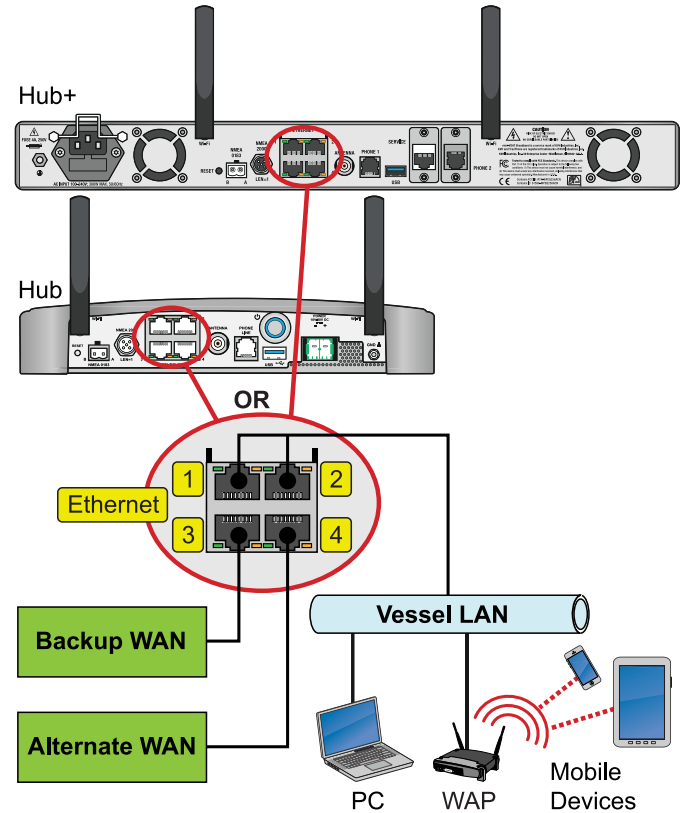

Note: KVH Manager will not report Backup or Alternate WAN data usage.

4. At the web interface, go to the Terminal Home page and verify that the Backup or Alternate WAN is connected and available for use.

Figure 61: Alternate and Backup WAN Tabs on Home Page

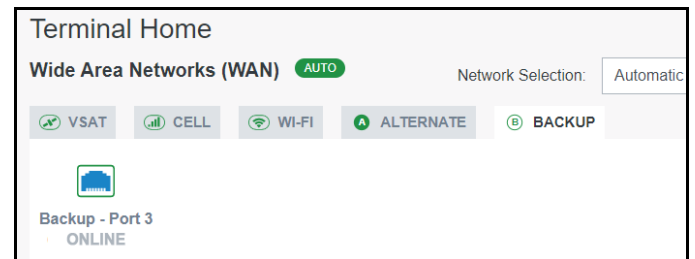

5. **(Hub+ Only)** Verify that the Backup or Alternate WAN status is shown on the BDU’s front panel touchscreen.

Figure 62: Alternate/Backup WAN Status on Hub+ Touchscreen

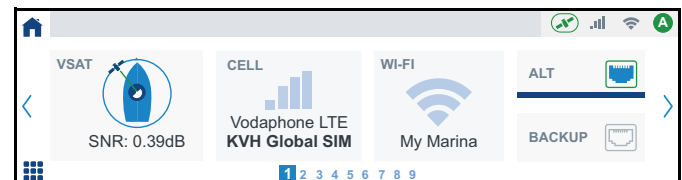

Educate the Customer

Give the Welcome Kit to the customer, make sure they know the administrator and Wi-Fi passwords, and show them how to use the system. Be sure they understand the following:

- The antenna transmits RF energy that is potentially harmful. Whenever the system is powered on, make sure everyone stays the minimum safe distance away from the antenna (see [page 1](#) for an illustration of the hazard area). If no-transmit zones were set up, make sure the customer understands where they are.
- Read the Master Services Agreement carefully (available at www.kvh.com/airtimeresources).
- Keep the radome installed on the antenna at all times. The radome protects the antenna's moving parts from wind, rain, and debris.
- The antenna must have a clear view of the sky to communicate via satellite. Common causes of blockage include masts, trees, buildings, and bridges. Dirt buildup on the radome can also affect communications.

Figure 63: Example of Satellite Blockage

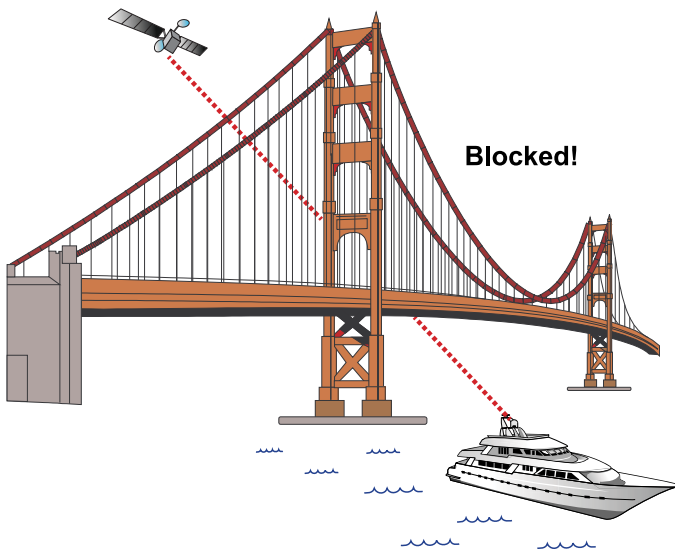

- The vessel must be located within the Ku-band HTS network coverage area to connect to the VSAT service (see www.kvh.com/tracnetmaps).
- The system must be activated for KVH ONE service (see www.kvh.com/airtimeresources).

- Data usage and overage alerts via email and text message can be configured easily over the Internet at the KVH Manager (see www.mykvh.com).

IMPORTANT!

If you are not a KVH Airtime customer, contact your Service Provider for details on accessing KVH Manager.

- Category Controls in KVH Manager are essential to managing VSAT data usage and ensuring that data is utilized for activities that matter most.

For More Information

Refer to the Help provided on the web interface's Support page.

Figure 64: Help Button on Support Page

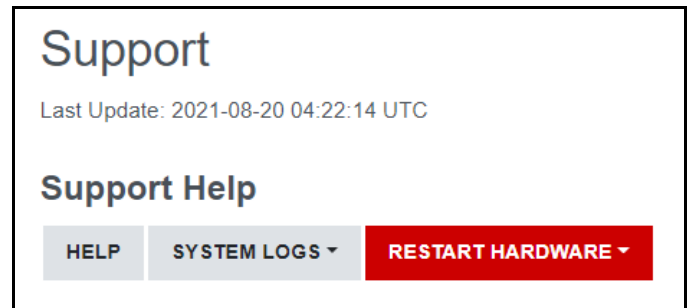

Appendix A: Terminating RG-58 Cable

These instructions explain how to terminate an RG-58 antenna cable with a PE4156 TNC connector using the tools from the RG-58 tool kit (KVH part no. 72-0982). A video of this procedure is available on YouTube, titled [Terminating an RG-58 Cable](#).

Note: For detailed instructions on terminating LMR-240 or LMR-400 cable, refer to the Times Microwave website: www.timesmicrowave.com.

1. Cut the cable evenly. Then gently round the end of the cable and make sure the center conductor is centered within the cable.

Figure 65: Cutting the Cable

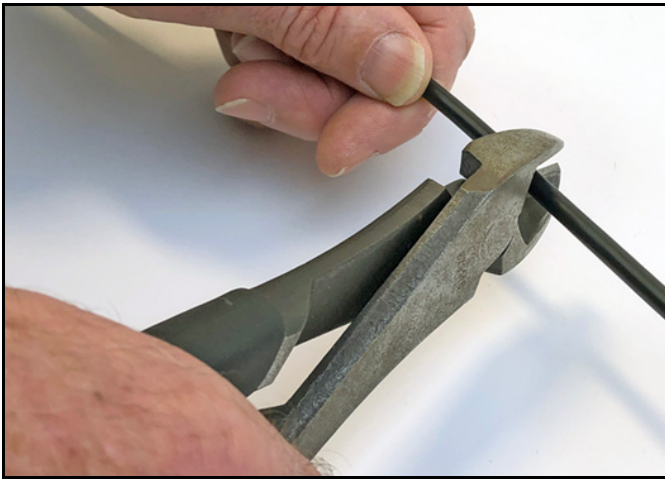

2. Push the rubber boot onto the end of the cable, narrow end first. *Applying a small amount of silicone grease to the cable jacket for lubrication will make it easier to slide the boot onto the end of the cable.*
3. Slide the metal ferrule onto the end of the cable.

Figure 66: Placing the Rubber Boot and Ferrule onto the Cable



4. Make sure the stripping tool is set up properly for RG-58 cable. Then depress the tab on the top of the tool and place the end of the cable into the cutting chamber. Be sure the end of the cable is flush with the edge of the tool that has the "58" label.

Figure 67: Inserting the Cable into the Stripping Tool

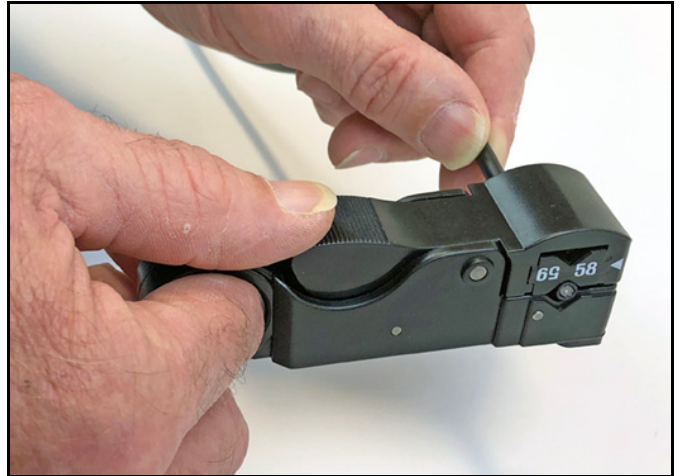

5. Once the cable is in position, release the tab. Then rotate the tool clockwise around the cable until the tool turns easily. Depress the tab and remove the cable from the tool.

Figure 68: Stripping the Cable

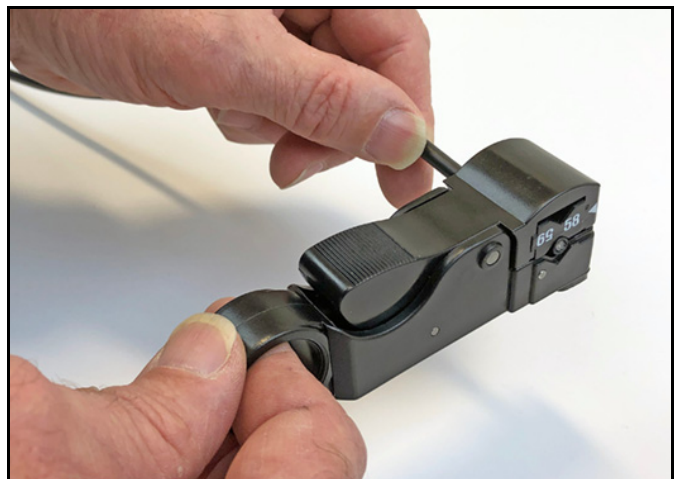

- Remove the debris from the end of the cable to expose the braid, dielectric, and center conductor. Carefully trim back any stray strands of braid that extend into the area of the exposed dielectric.

Figure 69: Properly Stripped Cable

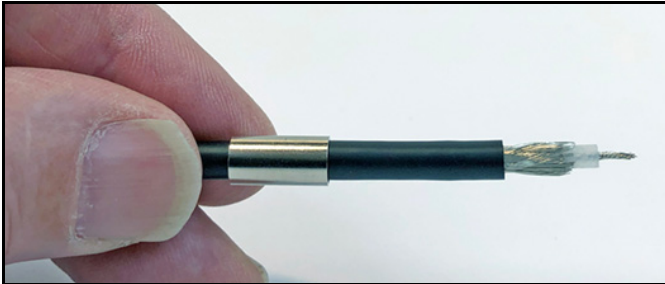

- Place the center pin into the crimp tool in the chamber labeled “.068”. Then insert the cable’s center conductor fully into the center pin. Crimp the center pin onto the center conductor.

Figure 70: Crimping the Center Pin onto the Center Conductor

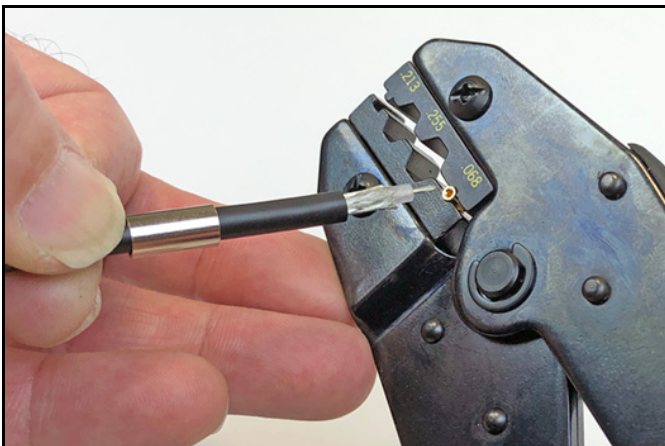
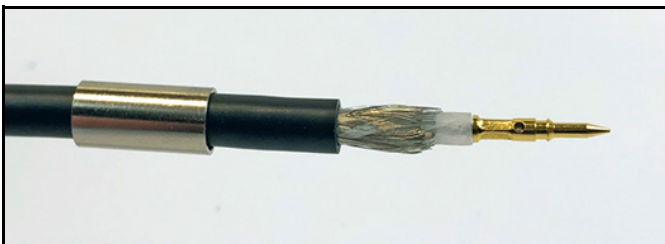
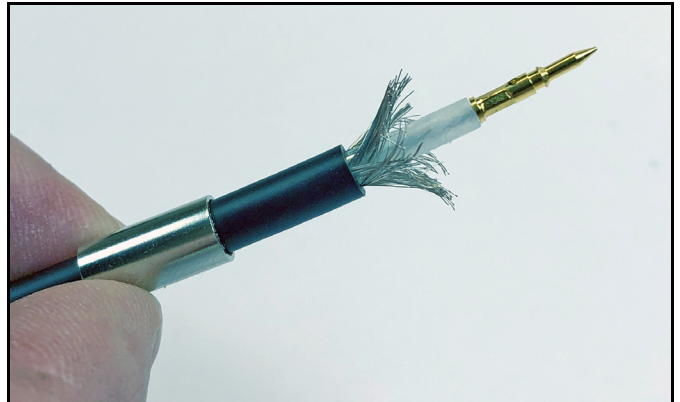

Figure 71: Center Pin Crimped in Place



- Gently flare the braid.

Figure 72: Flared Braid



- Insert the end of the cable into the neck of the connector until the center pin and dielectric are firmly seated inside. The connector should snap into place.

Figure 73: Pushing On the Connector

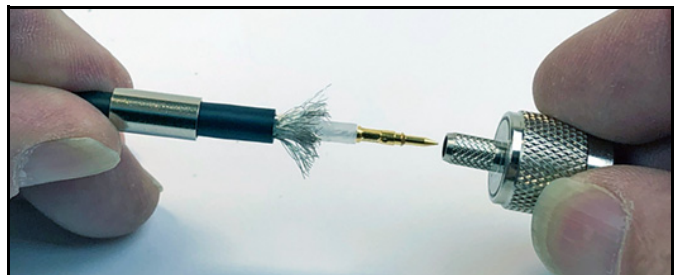
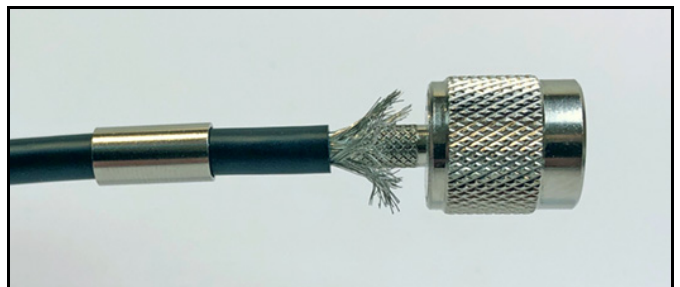
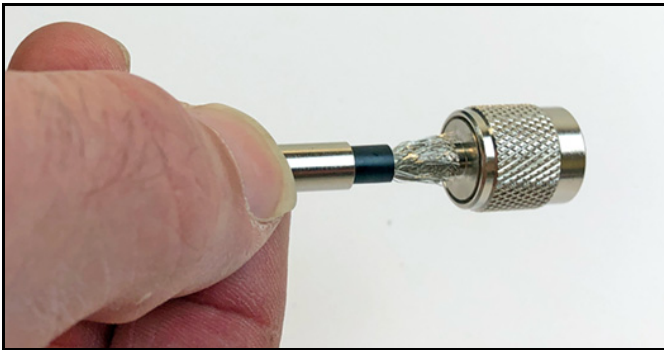

Figure 74: Connector Snapped into Place



10. Slide the ferrule up the cable and over the braid until it is flush against the connector shoulder.

Figure 75: Sliding the Ferrule over the Braid



11. Place the cable's connector into the crimp tool in the chamber labeled ".213". Be sure the tool abuts the connector shoulder so that the ferrule extends past the edge of the crimp tool.

Figure 76: Positioning the Connector in the Crimp Tool

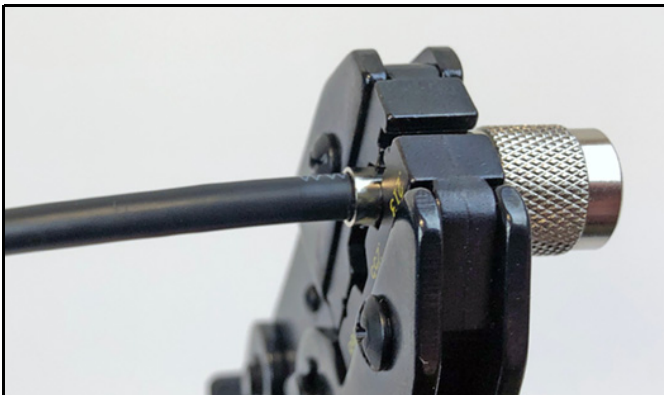

12. Crimp the ferrule in place. **Crimp only once.**

Figure 77: Crimping the Ferrule onto the Cable



Figure 78: Connector Properly Crimped in Place

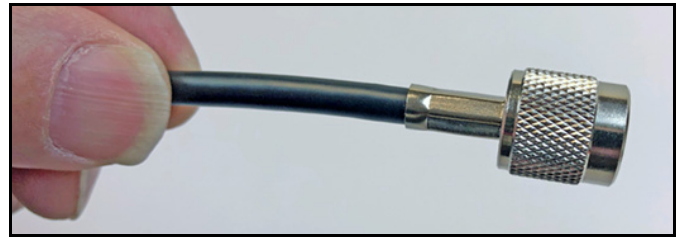

13. Push the rubber boot up the cable until it covers the entire ferrule.

Figure 79: Rubber Boot in Place Over Ferrule



14. Using a multimeter or similar device, check the continuity of the cable and make sure the center conductor is not shorted to the shield.

Appendix B:

Connecting Pigtail Cables to the Antenna Cable

Pigtail cables are required in the following circumstances:

- If you are not using a new RG-58 or LMR-240 cable, connect a pigtail cable between it and the BDU's TNC connector. The stiffness of other cable types can overstress the connector on the BDU. *You might use a pigtail cable at the antenna end as well to make it easier to maintain proper bend radius.*
- If you are reusing a preinstalled cable that has F-type or N-type connectors, use pigtail cables to convert to TNC connectors.

Three types of pigtail cables are available from KVH to accommodate different connectors (see Figure 80). All pigtail cables are 3 ft (1 m) in length. Be sure to order two if you need to connect one at each end of the antenna cable.

Figure 80: Pigtail Cables

Pigtail Cable	KVH Part No.
F-type (female) to TNC (male)	32-1440-003F
N-type (female) to TNC (male)	32-1440-003N
TNC (female) to TNC (male)	32-1440-003T

Follow the steps below to connect a pigtail cable to the antenna cable.

1. Slide a heat shrink sleeve onto the end of the pigtail cable for later use. *The heat shrink will protect the connection between the antenna cable connector and the pigtail cable connector.*
2. Fill half of the inner body of the antenna cable connector with the supplied silicone grease to prevent moisture and corrosion.
3. Connect and **SLOWLY** hand-tighten the male antenna cable connector to the female connector end of the pigtail cable, allowing the grease to diffuse and settle into the entire space within the connector.
4. Make sure the antenna cable connector is tightened all the way into the pigtail cable's connector. For N-type and TNC connectors, hand-tightening is sufficient. For F-type connectors, use as 7/16" torque wrench set to 20 in-lbs.
5. Seal the antenna cable-to-pigtail connection using self-vulcanizing tape or equivalent. Then protect the connection with the heat shrink.

Figure 81: Connecting the Antenna Cable to the Pigtail Cable

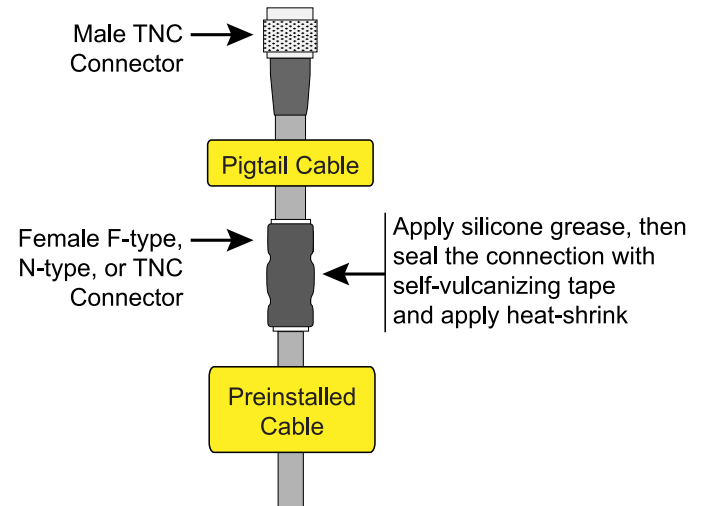

Appendix C:

Approved Cable Types

The following cable types have been approved by KVH for use with the TracNet system up to the specified maximum lengths. You can also refer to the TracNet Cable Wizard at www.kvh.com/TracNetcables for the latest information.

Note: If the cable type you would like to use is not listed below or at the Cable Wizard, please contact KVH Technical Support.

Note: All cables listed below are 50-ohm cables except where noted otherwise.

Cable Type	Maximum Length
LMR-195	150 ft (45 m)
LMR-200	200 ft (60 m)
LMR-240	300 ft (90 m)
LMR-400	500 ft (150 m)
LMR-400-75 (75-ohm)	500 ft (150 m)
LMR-600	500 ft (150 m)
LMR-600-75 (75-ohm)	500 ft (150 m)
RG-8	500 ft (150 m)
RG-8X	300 ft (90 m)
RG-11 (75-ohm)	150 ft (45 m)
RG-58	100 ft (30 m)
RG-213	500 ft (150 m)
RG-214	500 ft (150 m)
RG-223	200 ft (60 m)

Appendix D: Verifying the NMEA 0183 Message

Verify the message supplied by the NMEA 0183 talker by connecting its output to a laptop using an RS422-to-USB adapter cable and viewing its data stream using PuTTY, HyperTerminal, or other terminal emulator.

IMPORTANT!

To verify NMEA 2000 messaging, refer to the instructions that came with your NMEA 2000 talker.

Follow these instructions to verify the message.

Note: These example instructions assume you will be using PuTTY.

1. Using an RS422-to-USB adapter, connect the NMEA 0183 talker to the adapter's RS422 input. Then connect the adapter to the laptop's USB port.

Figure 82: Connecting a NMEA 0183 Talker to a Laptop

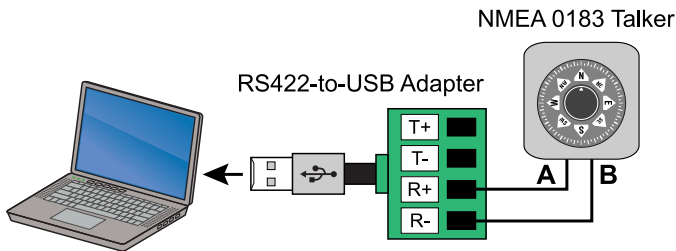

2. Start PuTTY and specify the laptop's port, connection type, and baud rate.

Figure 83: Starting PuTTY Options (Example)

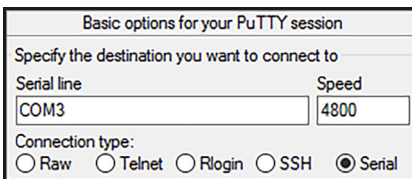

3. Configure options at the **Serial** configuration menu as follows:
 - 4800 baud
 - 8 data bits
 - 1 stop bit
 - no parity
 - no flow control

Figure 84: PuTTY Port Configuration Options (Example)

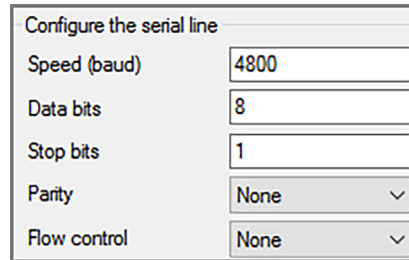

4. Select **Open** to view the message data in a command line window.

Figure 85: PuTTY Command Line Window (Example)

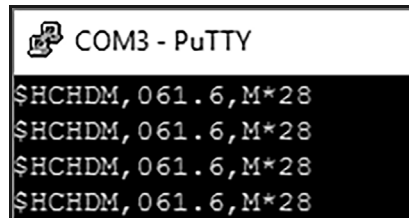

Appendix E: Wiring Diagram (Hub+ Option)

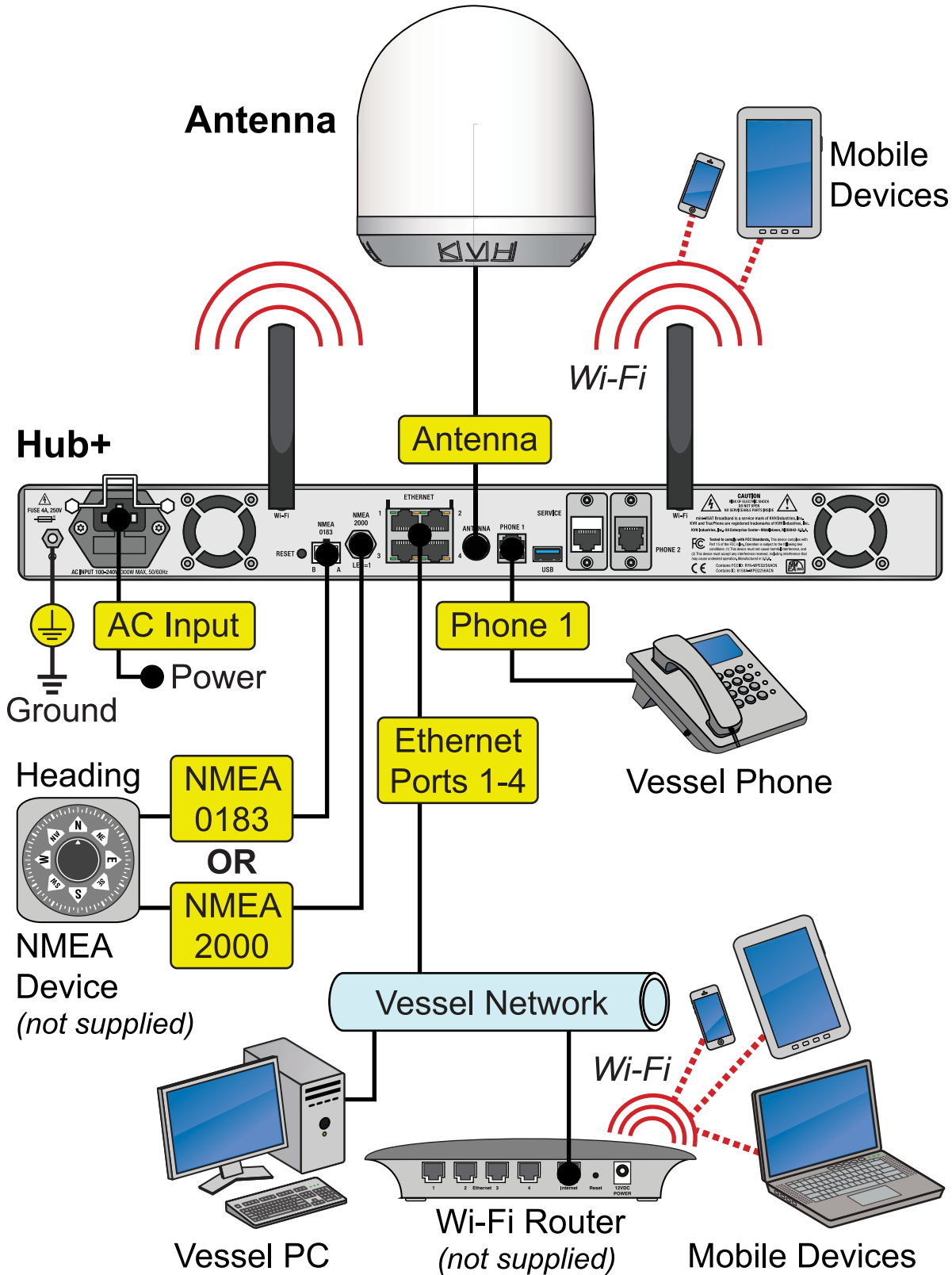

Appendix F: Wiring Diagram (Hub Option)

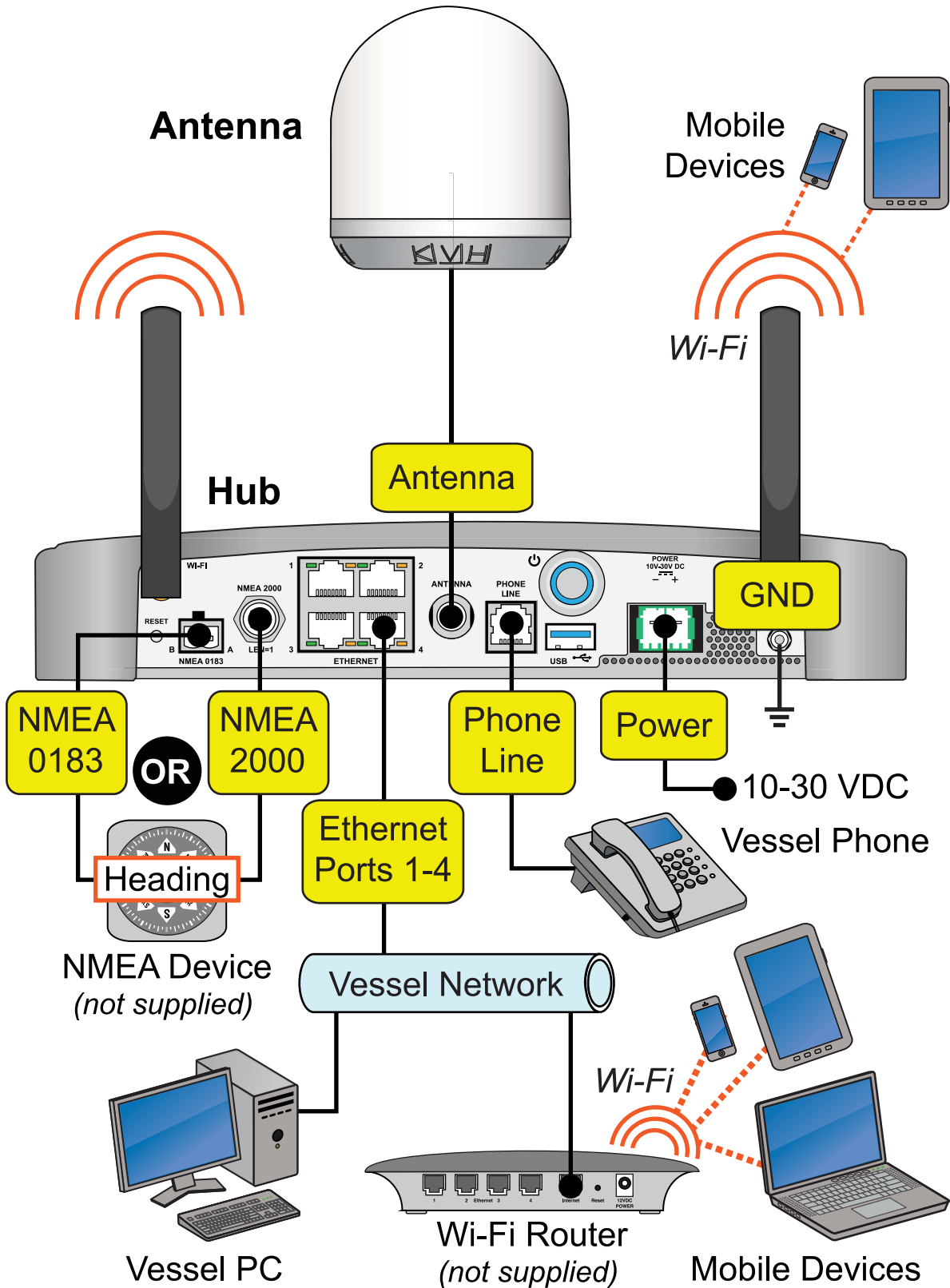



Regulatory Compliance

European Union Compliance

Hereby, KVH Industries, Inc. declares that the radio equipment type TracNet H30 complies with Directive 2014/53/EU. For the full text of the EU Declaration of Conformity, visit www.kvh.com/euconformity.

Federal Communications Commission Compliance



The TracNet system complies with Class A of Part 15 of the FCC (Federal Communications Commission) rules for radiated and conducted emissions.

FCC Identifiers: RYK-WNFQ261ACNIBT (TracNet Hub Wi-Fi)

RYK-WPEQ256ACN (TracNet Hub+ Wi-Fi)

XMR2020RM502QAE (Cellular Radio)

Use Conditions:

This device complies with part 15 of the FCC Rules. Operation is subject to the following two conditions:

1. This device may not cause harmful interference.
2. This device must accept any interference received, including interference that may cause undesired operation.

Note:

This equipment has been tested and found to comply with the limits for a Class A digital device, pursuant to part 15 of the FCC Rules. These limits are designed to provide reasonable protection against harmful interference when the equipment is operated in a commercial environment. This equipment generates, uses, and can radiate radio frequency energy and, if not installed and used in accordance with the instruction manual, may cause harmful interference to radio communications. Operation of this equipment in a residential area is likely to cause harmful interference in which case the user will be required to correct the interference at his or her own expense. However, there is no guarantee that interference will not occur in a particular installation. To determine if the equipment is interfering with radio or television reception, remove or apply power to the equipment and observe if the interference goes away, or returns, when the unit is off or on. The user is encouraged to try to correct the interference by one of the following measures:

- Reorient or relocate the receiving antenna.
- Increase the separation between the equipment and receiver.
- Connect the equipment into an outlet on a circuit different from that to which the receiver is connected.
- Consult KVH for assistance.

IMPORTANT:

- To meet FCC requirements, shielded Ethernet cables are required to connect the TracNet Hub or Hub+ to the ship's network.
- This equipment contains no user serviceable parts. Opening this unit will violate the warranty and may result in this equipment no longer complying with FCC requirements for Class A digital devices.





www.kvh.com



KVH Industries A/S
EMEA Headquarters
Birkerød, Denmark
Tel: +45.45.160.180 Fax: +45.45.160.181
Email: info@emea.kvh.com

KVH Industries, Inc.
World Headquarters
Bristol, RI U.S.A.
Tel: +1.401.847.3327 Fax: +1.401.849.0045
Email: info@kvh.com

KVH Industries Pte Ltd.
Asia-Pacific Headquarters
Singapore
Tel: +65.6513.0290 Fax: +65.6472.3469
Email: info@apac.kvh.com