

Installation Guide



TracNet™ Coastal



TracNet™ Coastal Installation Guide



This guide explains how to install the TracNet Coastal hybrid 5G cellular and Wi-Fi communications system. Operation instructions are provided in the Quick Start Guide.

Table of Contents

Important Safety Information.....	2	Appendices	
Inspect Parts and Get Tools.....	3	Wiring Diagram	22
Plan the Antenna Installation.....	4		
Prepare the Antenna Site	6		
Prepare the Antenna.....	7		
Mount the Antenna.....	9		
Mount the PoE Injector.....	10		
Wire the PoE Injector.....	11		
Configure the System.....	13		
Test the System.....	18		
Connect to an Existing Network.....	19		
Set Up Wi-Fi Calling	20		
Educate the Customer.....	21		

Who Should Install the System?

To ensure a safe and effective installation, KVH recommends that a KVH-authorized marine technician install the TracNet antenna. KVH-authorized technicians have the tools and electronics expertise necessary to install the system. To find a technician near you, visit www.kvh.com/wheretogetservice.

Technical Support

Within Continental U.S.A.: 1 866 701-7103

Worldwide: +1 401 851-3806

Email: mvbsupport@kvh.com

Trademark Information

KVH, TracNet, and the unique light-colored dome with dark contrasting baseplate (Reg. No. 2,864,752) are trademarks of KVH Industries, Inc.

All other trademarks are the property of their respective companies.

Disclaimer

Every effort has been made to ensure the correctness and completeness of the material in this document. No company shall be liable for errors contained herein. The information in this document is subject to change without notice. No warranty of any kind is made with regard to this material, including, but not limited to, the implied warranties of merchantability and fitness for a particular purpose.

Feedback

If you have any comments regarding this manual, please email them to manuals@kvh.com. Your input is greatly appreciated!

Important Safety Information



This icon indicates a danger, warning, or caution notice. Be sure to read these carefully to avoid injury.



WARNING Risk of Electric Shock

If any component of the TracNet Coastal system becomes damaged and/or no longer functions normally, disconnect it from vessel power, secure it from unintended operation, and contact KVH Technical Support (see [“Technical Support” on page 1](#)). All repairs or modifications must be performed by a trained, KVH-certified technician. If you are a KVH-certified technician, you still must contact KVH Technical Support prior to conducting any repairs or modifications to the equipment.



WARNING Risk of Explosion

Do not operate the PoE injector (or any other electrical device) in an environment where flammable gases, vapors, or dusts are present. In addition, do not operate the unit in an environment with a temperature outside its 5° F to 131° F (-15° C to 55° C) temperature range.



CAUTION Risk of Electric Shock

Failure to ground the TracNet Coastal system properly to ship's ground will cause an unsafe floating ground condition, risking potentially lethal electric shock. See [“Connect Power to the PoE Injector” on page 11](#) for details on the proper grounding of the equipment.



CAUTION RF Radiation Hazard

The antenna transmits up to 0.5 watts of radio frequency (RF) energy that is potentially harmful. Whenever the system is powered on, make sure everyone stays more than 10 inches (25 cm) away from the antenna. Additionally, the antenna must not be co-located or operate in conjunction with any other antennas or transmitters except in accordance with FCC multi-transmitter procedures.

Inspect Parts and Get Tools

Before you begin, follow these steps to ensure you have everything needed to complete the installation.

1. Unpack the box and ensure it contains everything shown in Figure 1 and on the Kitpack Contents List. Save the packaging for future use.

Figure 1: TracNet Coastal System Components

Antenna

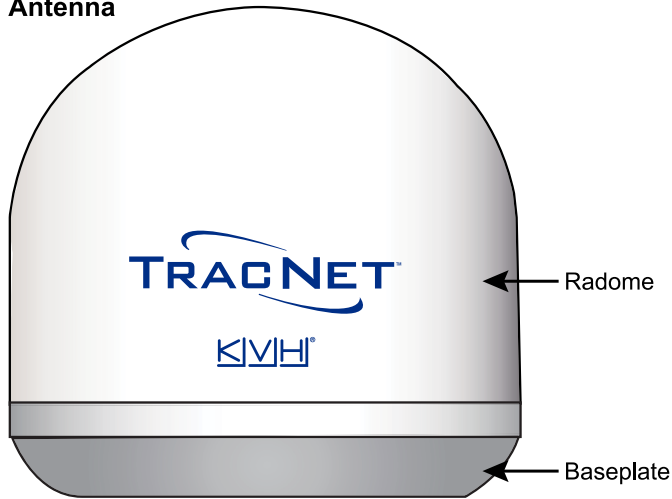

PoE Injector

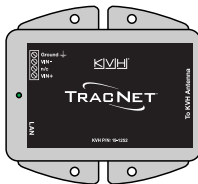

IMPORTANT!

Always lift the antenna by the baseplate and never by the radome or any portion of the internal antenna assembly.

- Silicone sealant or equivalent
- Eye protection
- Shop towels
- Multimeter
- Utility knife
- File
- Laptop PC with the latest Coastal antenna software downloaded from the KVH Partner Portal (www.kvh.com/partners), or a smartphone/tablet with the KVH Connect app installed and loaded with the latest antenna software

IMPORTANT!

Be sure to download the correct version of the software for your system's BDU type:

No Hub filename: Coastal_<version no.>.bin

2. Carefully examine all of the supplied parts to ensure nothing was damaged in shipment.
3. Gather the following tools and materials:
 - Flat-head and Phillips-head screwdrivers
 - 5/16" socket or wrench
 - Electric drill and 1/4" (6 mm) bit
 - 1" (25 mm) hole saw
 - Light hammer and center punch
 - Adhesive tape

Plan the Antenna Installation

Before you begin, consider the following installation guidelines below.

IMPORTANT!

Be sure to follow the guidelines below. Damage caused by an improper installation is not covered under KVH warranty.

Choose a Suitable Location

- Temperature must be within the operating range (-25°C to 55°C (-13°F to 131°F)).
- Be sure to mount the antenna near enough to the Hub to allow you to connect the KVH-supplied 50 ft (15 m) Ethernet cable between them.

Note: If you need to use a longer cable, optional 75 ft (22 m) (part no. 32-1516-0075) and 100 ft (30 m) (part no. 32-1516-0100) Ethernet cables are available from KVH.

IMPORTANT!

Never place the antenna in the beam path of the radar, regardless of distance. The radar's energy may damage the antenna or impair its performance.

Mounting Surface Requirements

Make sure the mounting surface is flat, level (within $\pm 2^\circ$), and wide enough to accommodate the antenna's base. Also make sure that the structure is strong enough to withstand the weight of the antenna (8 lbs, 3.6 kg), as well as other cumulative forces related to expected operating conditions, such as ice, snow, wash down, and maximum expected values of pitch, roll, and wind pressure (including gusts).

Recommendation: Random vibration of the mounting surface should measure less than 1.05 gRMS in each of three mutually perpendicular axes.

Note: Ship's crew should consult with the shipyard to ensure that the antenna mounting surface vibration never exceeds the above stated conditions at any time during its life.

Figure 2: Antenna Dimensions

Front View

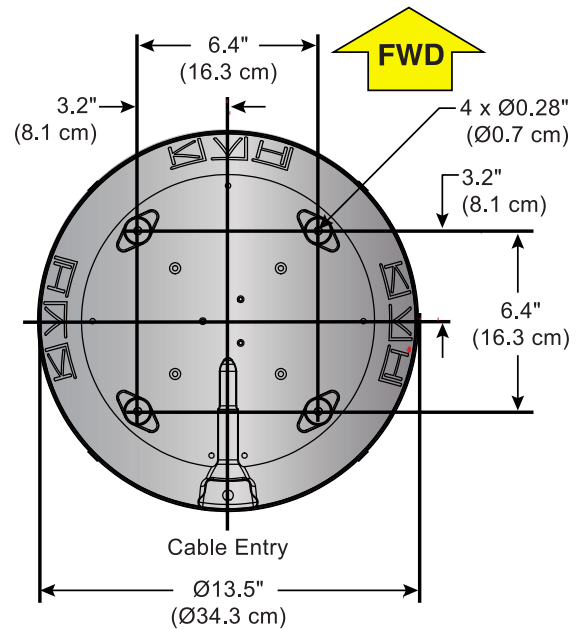
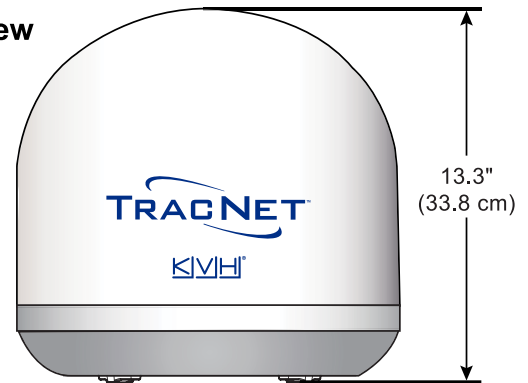

Bottom View

Minimize Cellular Blockage

Minimize blockage. Optimal performance requires a 360° clear view of the horizon at the highest possible vantage point to receive cellular signals. The fewer obstructions, the better the system will perform.

Figure 3: Blockage from Obstruction

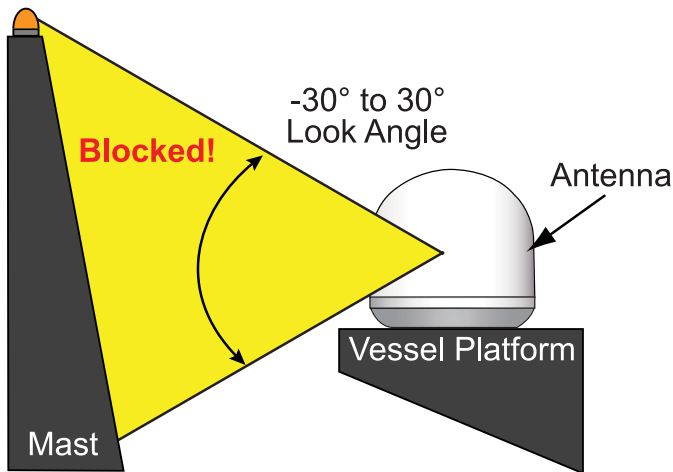

Avoid RF Interference

Although many variables determine the exact distance required between the antenna and radar/high-power radio transmitters, including transmit frequency/power, transmitter beam properties, and the reflective properties of nearby surfaces, consider the following general guidelines:

IMPORTANT!

RF emissions from radars and high-power radio transmitters may damage the antenna or impair its performance if it's improperly positioned within the beam path.

- Mount the KVH antenna as far away as possible from the radar and high-power radio transmitters.
- Do not mount the antenna at the same level as the radar. Most radar transmitters emit RF energy within an elevation range of -15° to $+15^\circ$. Therefore, mount the antenna outside this elevation range and at least 3 ft (1.5 m) away from the transmitter.

IMPORTANT!

Never place the antenna in the beam path of the radar regardless of distance. Radar energy may damage the antenna or impair its performance.

Figure 4: Avoiding RF Interference

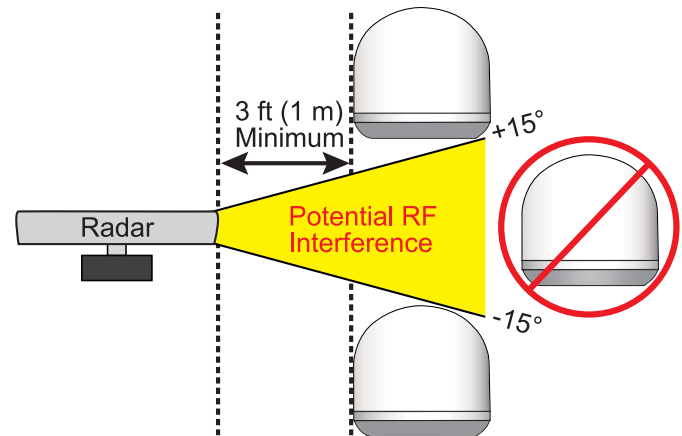

Prepare the Antenna Site

Once you have identified a suitable antenna mounting site, follow these steps to prepare the mounting site for installation.

1. Unfold the antenna mounting template (supplied in the Welcome Kit) and place it on the mounting surface. Make sure the "FWD" (forward) arrow points toward the bow and is parallel to the vessel's centerline as shown in Figure 5. Tape in place.
2. Using a light hammer and center punch, mark the locations for the four mounting holes and cable access hole on the mounting surface in the locations indicated on the template.
3. Drill a 1/4" (6 mm) hole at the four mounting hole locations you marked in step 2. Later, you will insert four #10-32 screws through these holes to secure the antenna to the mounting surface.

Figure 5: Antenna Mounting Holes Layout

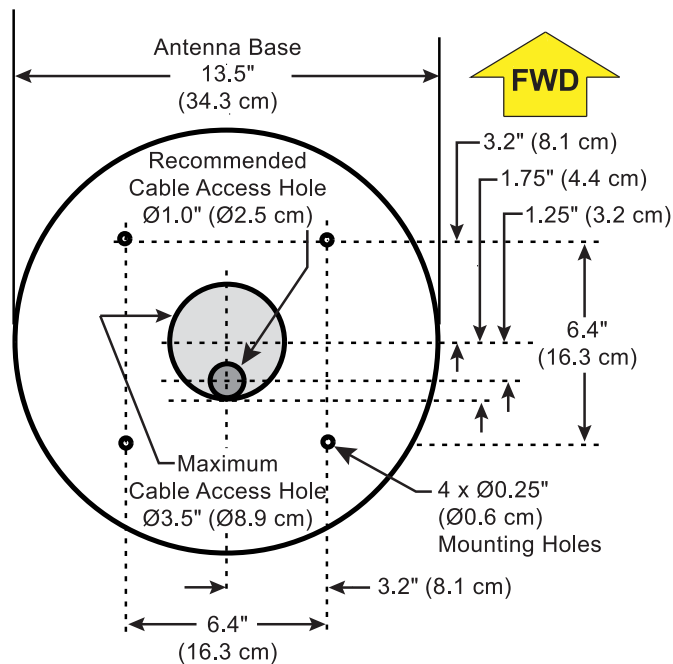

4. Using a hole saw, drill the cable access hole in the location you marked in step 2. Be sure to size the hole appropriately to maintain a cable bend radius of at least 2.6" (6.6 cm). If the hole location is in the center of the antenna mounting hole pattern, the diameter of the cable access hole must not exceed 3.5" (89 mm). Smooth the edges of the hole to protect the cable. Later, you will route the antenna's Ethernet cable through this hole and into the vessel.
5. Clean and dry the antenna mounting surface.

6. Peel off the paper backing from the supplied foam seal to expose the adhesive. Then press the foam seal down firmly onto the mounting surface, ensuring the hole in the foam seal aligns with the cable access hole in the mounting surface.

Figure 6: Foam Seal



Prepare the Antenna

Follow these steps to prepare the TracNet Coastal antenna for installation.

1. Attach the four rubber mounting feet (*supplied in kit*) to the bottom of the antenna at locations shown in Figure 7.

IMPORTANT!

Be sure to install the rubber feet. They are required to isolate the antenna from vibration.

Figure 7: Attaching the Rubber Feet

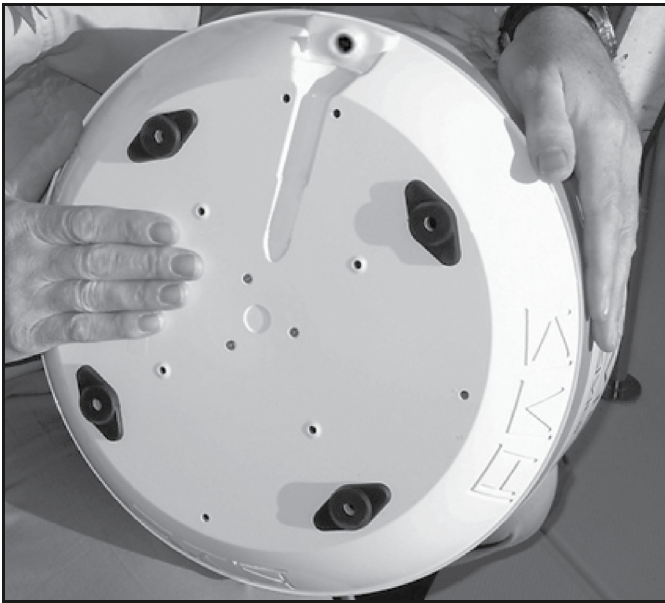

2. Remove the four #8-32 screws securing the radome to the antenna.

Figure 8: Removing the Radome

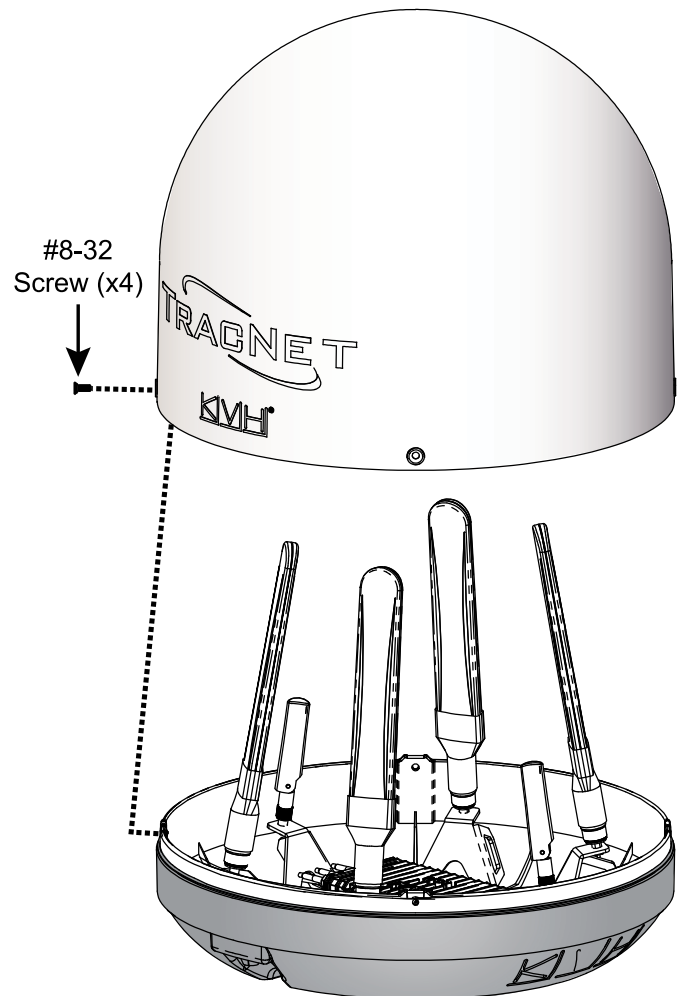

3. Carefully lift the radome straight up until clear of the antenna assembly and set it aside in a safe place.

If you keep the radome topside, secure it with a lanyard to prevent it from falling overboard. Also, do not place the radome on a hot steel deck – the heat may warp the radome.

4. Remove but do not discard the push-in grommet from the cable entry hole in the baseplate.
5. Feed the Ethernet cable (*supplied in kit*) through the cable entry hole.
6. Connect the Ethernet cable to the TCM's (Terrestrial Communications Module) Ethernet port.
7. Secure the Ethernet cable to the antenna frame using a tie-wrap (*supplied in kit*).

Figure 9: Connecting the Ethernet Cable

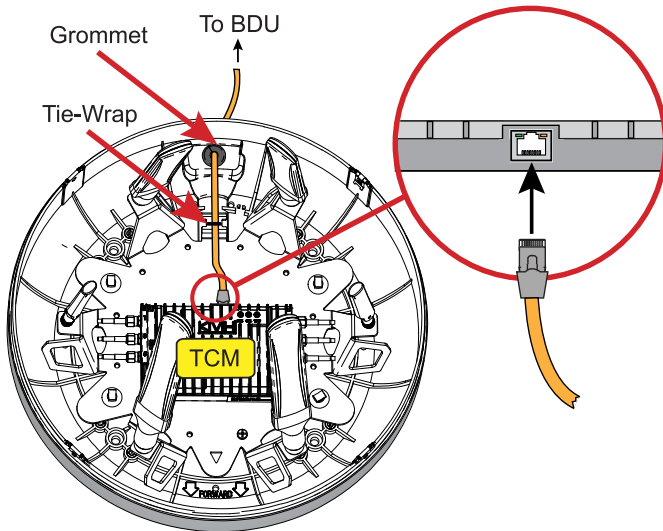

8. Attach the push-in grommet that you removed in step 4 to the cable near the cable entry hole. Then reinstall the grommet in the cable entry hole.
9. Route the other end of the cable along the cable channel underneath the baseplate and belowdecks through the cable access hole. Leave an adequate service loop, 14" (36 cm) in diameter, at the antenna location for serviceability.
10. Weatherproof and seal the cable access hole as required.

Mount the Antenna

Follow these steps to mount the antenna to the mounting surface.

1. Place the antenna baseplate over the holes drilled in the mounting surface. Ensure the “Forward” arrow inside the baseplate points toward the bow and is parallel to the vessel’s centerline.

Figure 10: Forward Arrow in Antenna Baseplate

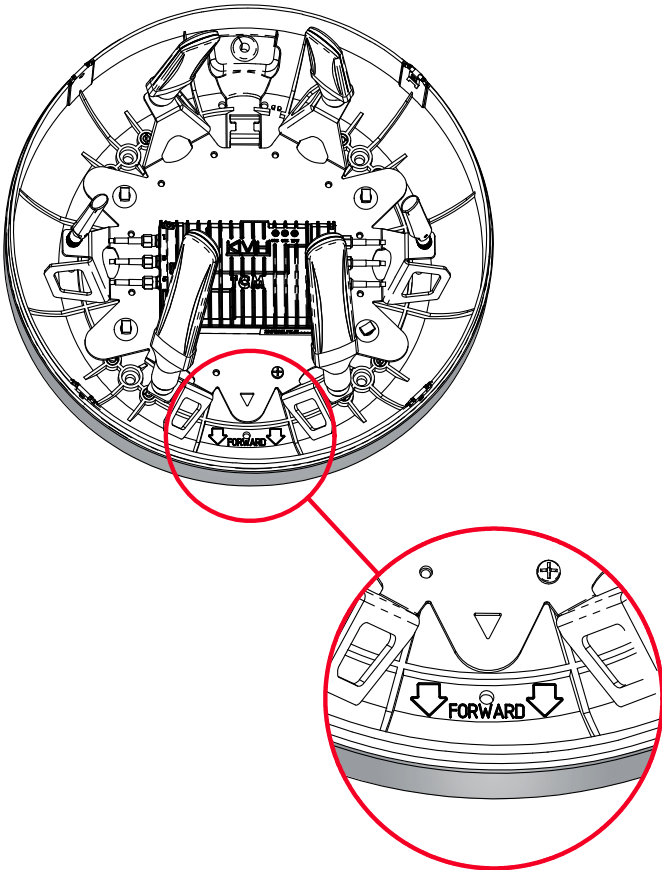

IMPORTANT!

Be sure to insert the mounting bolts from above and use the supplied hardware for a secure installation.

2. Apply a thin layer of the supplied anti-seize lubricant to the threads of the four #10-32 Phillips screws. *Two different lengths are included in the kitpack – use the screws that work best for your installation.*



CAUTION

Be sure to observe the safe handling instructions in the Material Safety Data Sheet (MSDS) provided with the anti-seize lubricant.

3. At each of the four baseplate mounting holes, place a 7/16" -diameter #10 flat washer on a #10-32 Phillips screw and insert the screw into the hole from above (see Figure 11)

Figure 11: Mounting Hardware

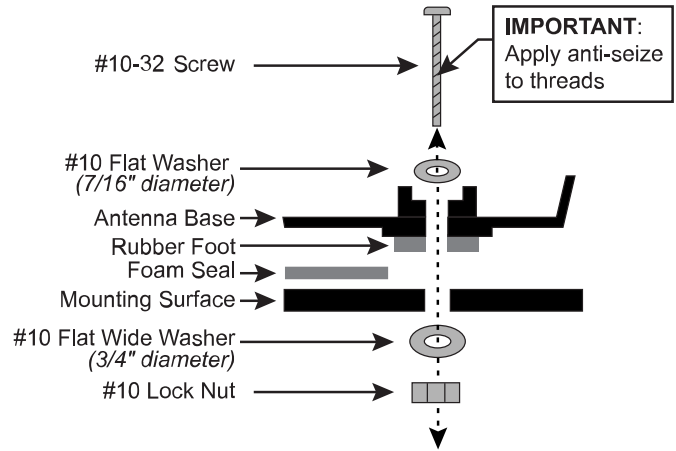

4. Secure each mounting bolt to the mounting surface using a 3/4" -diameter flat washer and a #10 lock nut from below. Using hand tools, tighten all four screws until the four rubber feet on the baseplate are bottomed against the mounting surface and the foam seal is fully compressed.

IMPORTANT!

Use only manual hand tools to tighten the mounting screws. The torque from a power tool might distort the antenna baseplate.

5. Reinstall the radome onto the antenna. The radome’s “TracNet” labels should face fore and aft. Secure in place with the four #8-32 screws you removed earlier and tighten to 5 in-lbs of torque. Hide and protect the screws with the plastic screw caps (*supplied in kit*).

Mount the PoE Injector

Follow these steps to mount the PoE injector in a suitable location.

Note: You may use your own PoE+ PSE (power sourcing equipment) device instead of the supplied PoE injector.

Select a Location

Consider these installation guidelines.

- Select a cool, dry, well-ventilated area belowdecks away from any heat sources or salt spray.
- Be sure the PoE injector's power LED light will be visible to the user.
- Select a location that will provide adequate clearance for the PoE injector dimensions and leave plenty of room to accommodate adequate service loops and strain-relief.

Figure 12: PoE Injector Dimensions

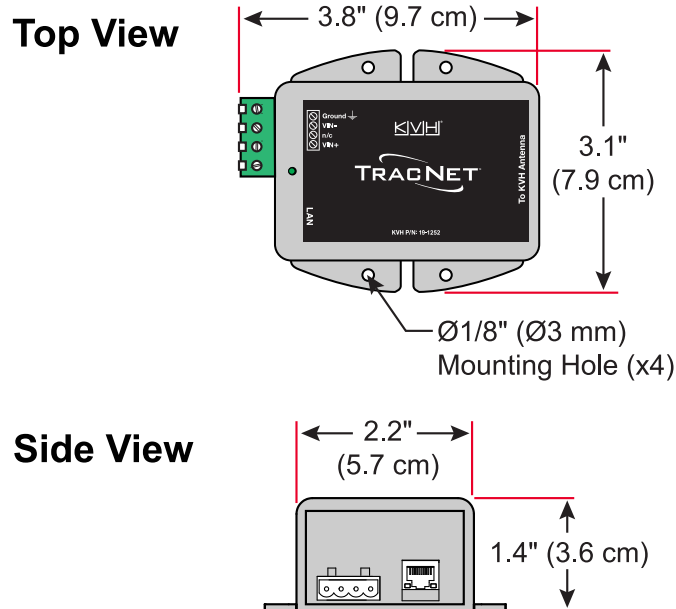

Mount the PoE Injector

Follow these steps to install the PoE injector.

1. Using the PoE injector itself as a guide, mark the locations of each of the four mounting holes.
2. Drill a 1/8" (0.3 cm) hole at the four mounting hole locations you marked in step 1.
3. Secure the PoE injector using fasteners that are appropriate for the mounting surface's construction.

Wire the PoE Injector

Follow the steps below to wire the PoE injector to the antenna and connect power to the system.

Connect the Antenna to the PoE Injector

Connect the Ethernet cable from the antenna to the “To KVH Antenna” Ethernet port on the PoE injector.

IMPORTANT!

Do not connect anything other than the antenna’s Ethernet cable to the PoE injector’s “To KVH Antenna” Ethernet port. The PoE injector supplies voltage that will damage other devices, such as laptop computers.

Figure 13: PoE Injector Antenna Connection

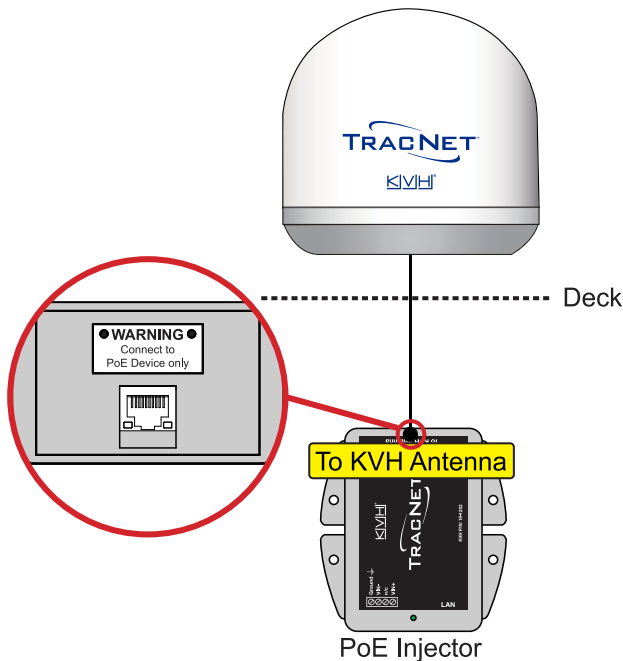

Connect Power to the PoE Injector

Note: An optional 24 VDC AC-DC power supply (2.5A, 60 W) is available from KVH (part no. 72-1072).

1. Before you begin, disconnect vessel power.
2. Connect the PoE injector’s power cable wires to the supplied 4-position terminal strip connector as shown in Figure 14 and described below:

- Connect the green wire from “Ground” on the terminal strip connector to ship’s ground.
- Connect the black wire from “Vin-” on the terminal strip connector to DC Return.

Note: The third terminal is unused.

- Connect the red wire from “Vin+” on the terminal strip connector to the vessel’s 10-30 VDC power source (the system draws 14W max (10 W nominal)).
3. Insert a fuse (supplied in kit) into the in-line fuse holder. If vessel power supplies 12 volts, use the purple 3A fuse. If it supplies 24 volts, use the gray 2A fuse.

Figure 14: TracNet Coastal System Power

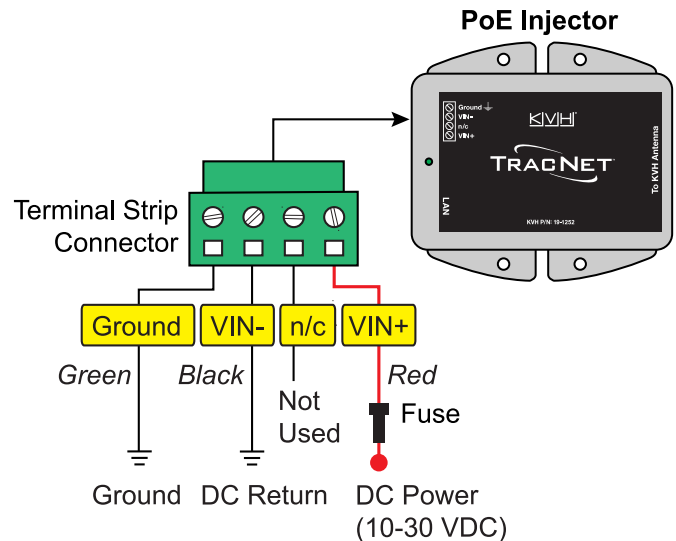

**if vessel power supplies 12 volts, use purple 3A fuse;
if vessel power supplies 24 volts, use gray 2A fuse*

Check for Proper Grounding

1. Check for proper grounding by using a multimeter to measure the AC and DC voltages at the ground and DC return terminal pins. The measured voltage should be less than 2 VAC and 2 VDC. A higher voltage indicates a dangerous floating ground condition.
2. Reconnect vessel power and turn on the circuit breaker to apply power to the antenna system. Within seconds, the Power light on the PoE injector should illuminate green.

Figure 15: PoE Injector Power Light Location

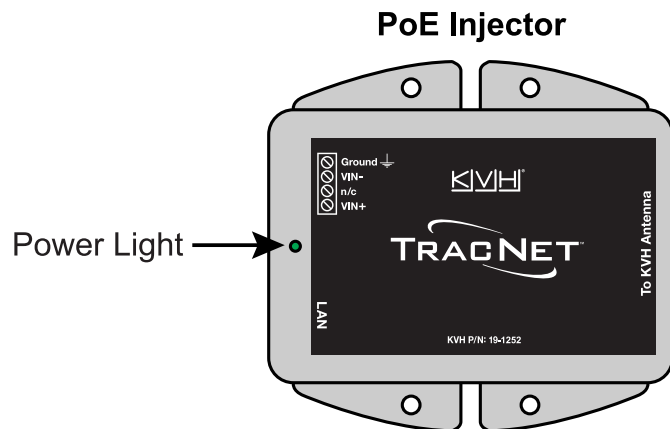

3. Repeat step 1 with the circuit breaker turned on, looking for the same measured result.



WARNING

If you measure 2 volts or greater at the power/ground cable's terminal connector, notify the ship's electrician or authorized vessel representative immediately. This is a dangerous condition. Do not touch the PoE injector or connect anything to it until the problem is fixed.

Configure the System

Follow the steps on the next few pages to access the setup wizard and configure the system for use.

Access the Setup Wizard

Follow the steps for either option below to access the setup wizard.

Option 1: Using the Ethernet Connection

1. Connect a laptop PC configured for DHCP directly to the LAN port on the PoE injector.
2. Start the web browser and enter **<https://kvhonboard.com>**.

Note: If the setup wizard is not displayed, try entering <https://192.168.5.1>, which is the default IP address. You might need to bypass a warning from your browser to proceed to the site.

Option 2: Using an Existing Network

1. Connect your vessel network to the LAN port on the PoE injector.
2. Start the web browser on a device connected to the vessel network and enter **<https://kvhonboard.com>**.

Note: If the setup wizard is not displayed, try entering <https://192.168.5.1>, which is the default IP address. You might need to bypass a warning from your browser to proceed to the site.

Figure 16: Connect Using the LAN Port

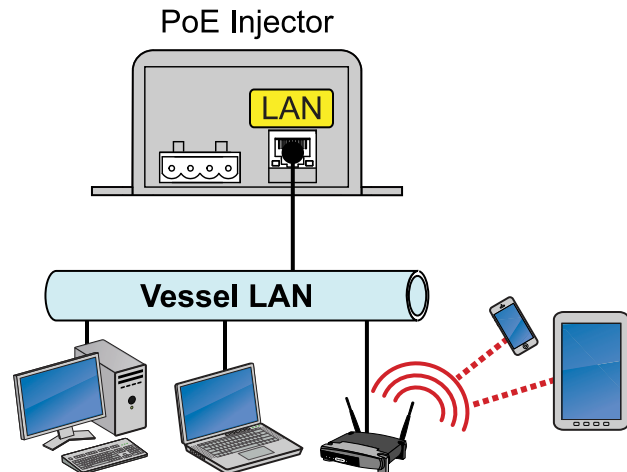

Run the Setup Wizard

The Setup Wizard appears upon initial startup to step you through system configuration. Through the setup wizard, you will:

- Enter administrator and guest account passwords
- Enter the vessel name
- Configure LAN settings (optional)
- Configure WAN settings (optional)

Follow the steps in the following sections to set up the system.

Note: After setup is complete, you must log into the web interface as an administrator to make further changes to the system settings.

Figure 17: Wizard Welcome Screen

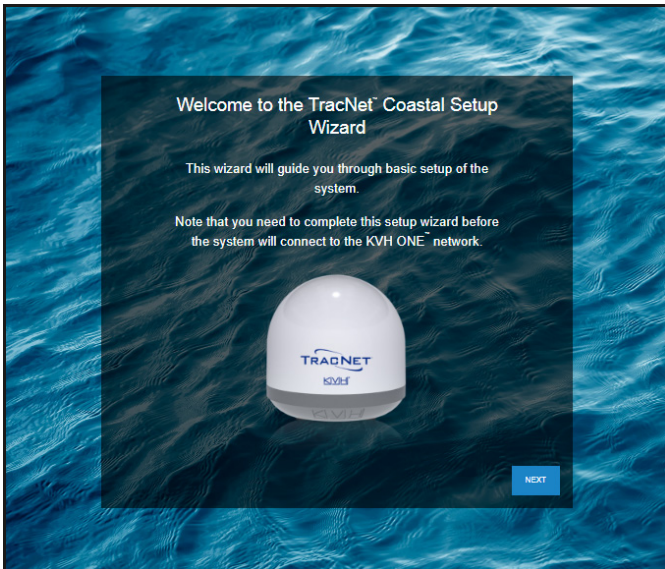

Assign an Administrator Password

At the first page of the wizard, you must set the following:

- **PASSWORD:** Enter and then re-enter an administrator password of the customer's choice
- **VESSEL NAME:** Enter the vessel name

Note: The case-sensitive password must be between 8 and 64 characters in length, with at least one uppercase letter, one lowercase letter, one number, and a special character.

When you are done, select **Next**.

Figure 18: Assigning the Administrator Password

Assign Administrator Account Information * = Required field

The Administrator account has read/write access for configuration changes to the terminal.

USER NAME	admin
PASSWORD*	<input type="password" value="*****"/>
CONFIRM PASSWORD*	<input type="password" value="*****"/>
VESSEL NAME*	<input type="text" value="Loopers-TC-1"/>

Cancel
NEXT

Assign a Guest Account Password (Optional)

At the second page of the wizard, you can set the following:

- **PASSWORD:** Enter and then re-enter a guest account password of the customer's choice

Note: The case-sensitive password must be between 8 and 64 characters in length, with at least one uppercase letter, one lowercase letter, one number, and a special character.

When you are done, select **Next**.

Figure 19: Assigning the Guest Password

Assign Guest Account Password (optional)

The Guest account allows read-only access to terminal status and configurations.

USER NAME	guest
PASSWORD
CONFIRM PASSWORD

BACK NEXT

Configure Ethernet Settings (Optional)

At the third page of the wizard, you can make any necessary changes to the following Ethernet settings:

IMPORTANT!

The default LAN settings work well for most installations. Do not change these settings unless absolutely necessary, such as to avoid conflicts with an existing onboard network.

- **IP ADDRESS:** Change the default IP address
- **SUBNET MASK:** Change the default subnet mask
- **DHCP MODE:** Set to "ON" or "OFF" (If DHCP is on, select a **DHCP START** and **DHCP END** range)

Note: By default, the LAN has a gateway of 192.168.5.1 and assigns IP addresses in the 192.168.5.50-150 range.

Figure 20: Configuring Ethernet Settings

Configure LAN Settings (optional)

Modify IP settings only if necessary to avoid conflicts with an existing onboard network. Set a unique password for Wi-Fi access to the terminal.

Ethernet Settings

IP ADDRESS	192.168.5.1
SUBNET MASK	255.255.255.0
DHCP MODE	<input checked="" type="radio"/> ON <input type="radio"/> OFF DHCP Start: 192.168.5.50 DHCP End: 192.168.5.150 Advanced >

Configure WAN Settings

With its hybrid network capability, the TracNet system can automatically switch to an available shore-based Wi-Fi network for Internet connectivity. At the fifth page of the wizard, select the shore Wi-Fi network or networks that the TracNet system should use.

The wizard lists any Wi-Fi networks it has detected broadcasting in the area. You may select one or more networks from this list and enter associated password(s).

To add a network not shown in the list, select **Advanced Wi-Fi Settings**. Select “+”. Then enter the network name, security protocol, and password.

Figure 21: Configuring WAN Settings

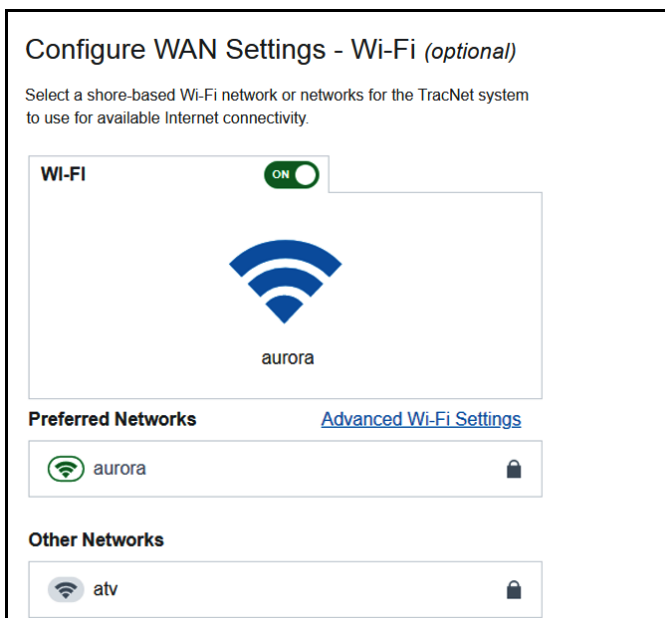

When you are done, select **Next**. At the final screen, select **Exit Wizard**. Then wait a few minutes for the system to apply the new settings. When the login page appears, enter the admin credentials to access the web interface.

Note: If you changed the Ethernet settings and the login page does not appear after a few minutes, try entering in your browser the correct IP address for the port or Wi-Fi that you are using to connect. You can also try renewing the DHCP lease on your device.

Update the System Software

Follow these steps to check the currently installed software versions and install new software, if necessary.

Note: This procedure explains how to update the software using the web interface and your laptop computer. However, you can also update the software using the KVH Connect mobile app. Details are available in the Help.

1. At the web interface, go to the **Software Updates** page. Note the displayed software version for the TCM (antenna).

Figure 22: Software Updates Page

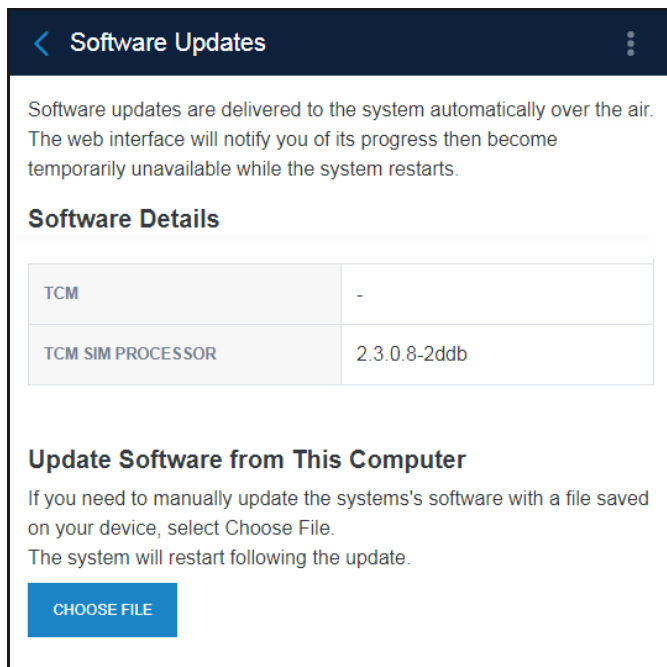

2. If the reported software versions are earlier than the latest version you downloaded from the KVH Partner Portal or KVH Technical Support, select **CHOOSE FILE**.
3. Select the software update file you saved on your laptop. Be sure it is the correct version of Coastal software for your system's BDU type: **Coastal** for no Hub.
4. Wait for the software update to complete. **Do not turn off power to the system during this update.**
5. Reconnect to the web interface and verify that the Software Updates page is now displaying the latest version.

Test the System

1. Turn on all other electronic equipment above deck within the proximity of the antenna, if possible. Verify that both the KVH system and the electronic equipment continues to operate without any degradation in performance.
2. At the web interface, go to the Home page and select the Cell tab. If there is cellular service in your area, select the **Cell Only** network mode. Then open a new browser tab and try to access the Internet (such as google.com) over the cellular connection.

Figure 23: Cell WAN Status

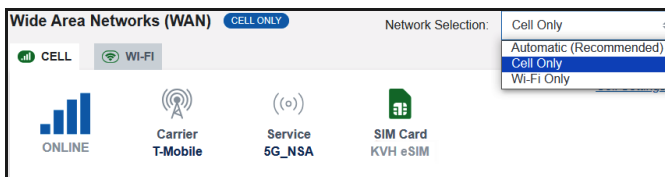

3. If you set up the system for a shore Wi-Fi network, select the Wi-Fi tab. If there is adequate Wi-Fi service in your area, select the **Wi-Fi Only** network mode. Then open a new browser tab and try to access the Internet (such as google.com) over shore Wi-Fi.

Figure 24: Wi-Fi WAN Status

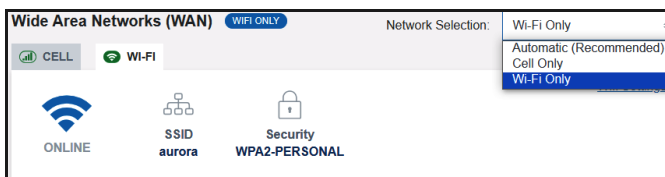

4. Return the system to **Automatic** network mode.

Connect to an Existing Network

If you already have an existing LAN on the vessel, you can connect its router to the TracNet Coastal system. Then all devices on the network will have access to the Coastal service. Simply connect a standard Ethernet cable from the WAN (Internet) port on the router to the LAN port on the Coastal system's PoE injector.

Note: Unless you changed the LAN settings at the Setup Wizard, the LAN has a gateway of 192.168.5.1 and assigns IP addresses in the 192.168.5.50-150 range.

Figure 25: Connect Using an Existing Network

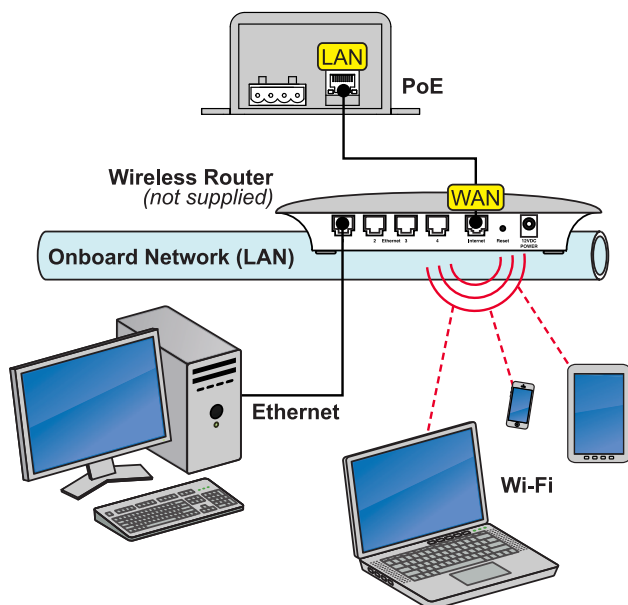

Set Up Wi-Fi Calling

You can make voice calls using your smartphone via the TracNet Coastal system if Wi-Fi Calling is supported by your phone's cellular service provider. Simply enable the Wi-Fi Calling feature on your phone. Follow the basic steps below or refer to your device's user documentation.

Note: You might need to enter an emergency address when you enable Wi-Fi Calling.

Enabling Wi-Fi Calling on an iPhone

1. Navigate to **Settings > Phone > Wi-Fi Calling**.
2. Using the slider, turn on "Wi-Fi Calling on This iPhone."

Figure 26: Wi-Fi Calling Enabled on an iPhone

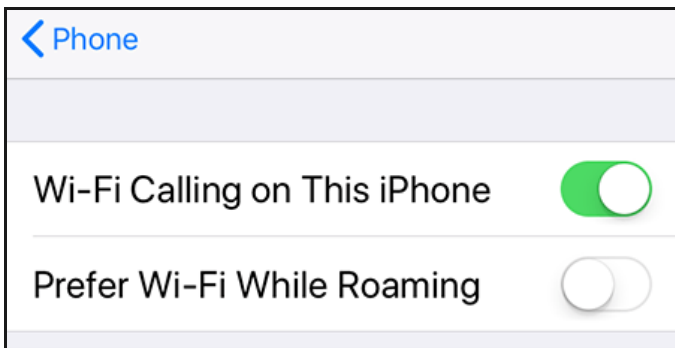

Enabling Wi-Fi Calling on an Android Phone

1. Tap the Phone app.
2. Navigate to **Settings > WI-FI Calling**.
3. Using the slider, enable Wi-Fi calling (changes from "Disabled" to "Ready for calls").

Note: Phone settings screens may vary.

Figure 27: Wi-Fi Calling Enabled on an Android Phone

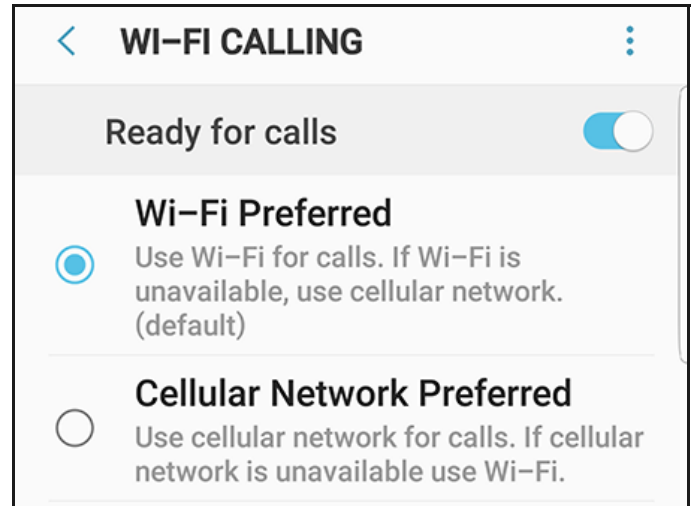

Educate the Customer

Give the Welcome Kit to the customer, make sure they know the administrator and Wi-Fi passwords, and show them how to use the system. Be sure they understand the following:

- Read the Master Services Agreement carefully (available at www.kvh.com/airtimeresources).
- Keep the radome installed on the antenna at all times. The radome protects the antenna from wind, rain, and debris.
- Data usage and overage alerts via email and text message can be configured easily over the Internet at the KVH Manager (see www.mykvh.com).

IMPORTANT!

If you are not a KVH Airtime customer, contact your Service Provider for details on accessing KVH Manager.

For More Information

Refer to the Help provided from the main menu of the web interface.

Figure 28: Help Option in Main Menu

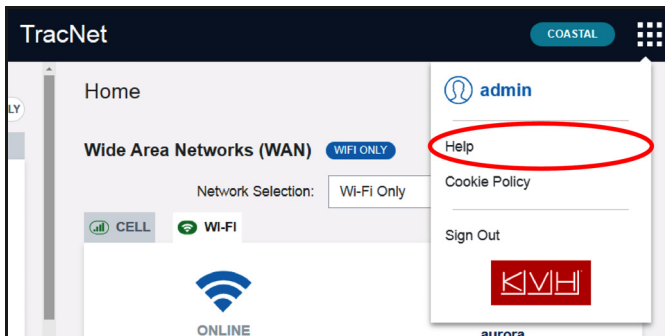

Appendix A: Wiring Diagram

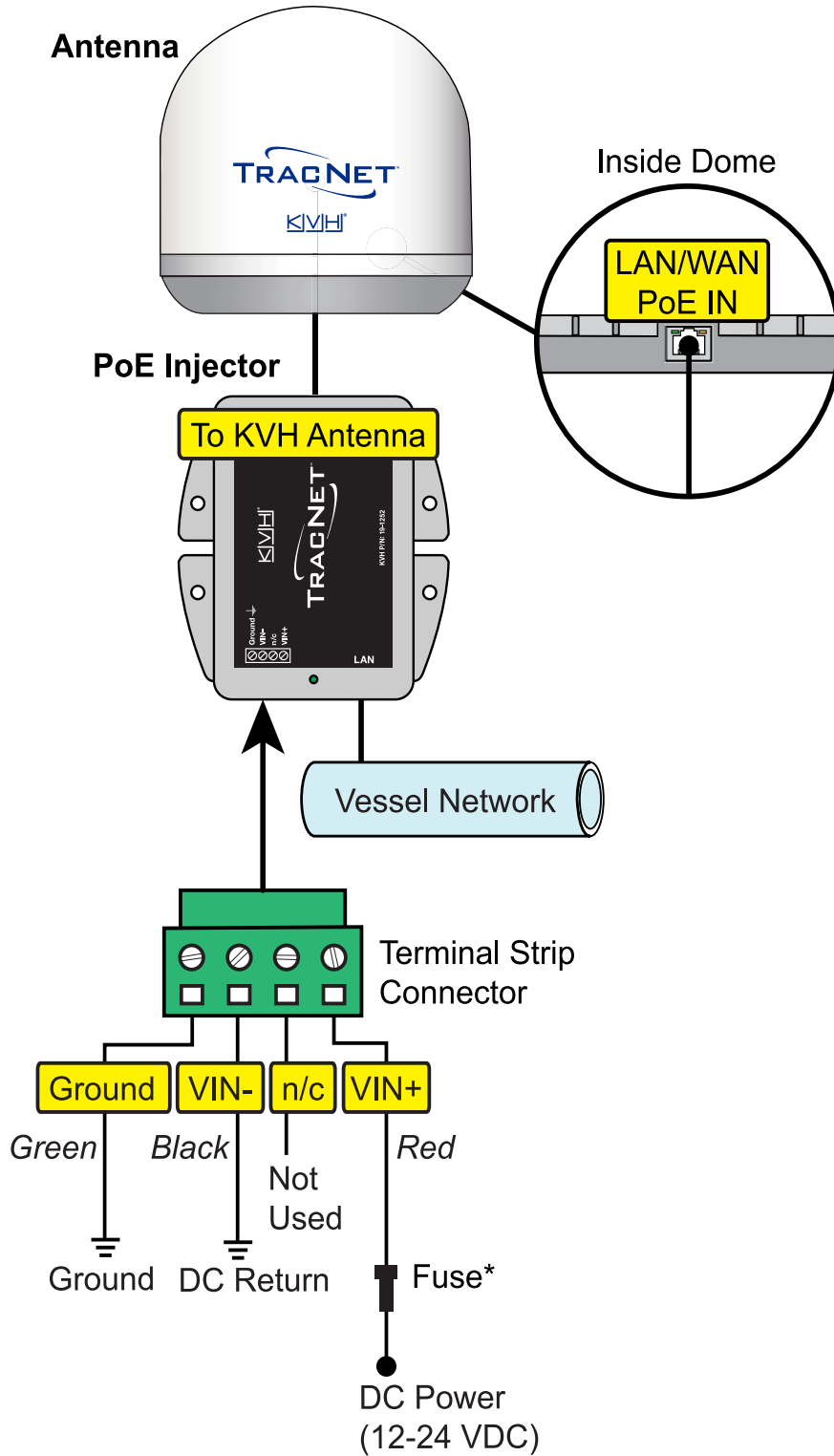

**If vessel power supplies 12 volts, use purple 3A fuse
If vessel power supplies 24 volts, use gray 2A fuse*



Regulatory Compliance

European Union Compliance

Hereby, KVH Industries, Inc. declares that the radio equipment type TracNet Coastal Pro is in compliance with Directive 2014/53/EU. For the full text of the EU Declaration of Conformity, go to www.kvh.com/euconformity.

Federal Communications Commission Compliance



The TracNet system complies with Class B of Part 15 of the FCC (Federal Communications Commission) rules for radiated and conducted emissions.

FCC Identifiers: RYK-WPEQ256ACN (TracNet Hub Wi-Fi)

XMR2020RM502QAE (Cellular Radio)

Use Conditions:

This device complies with part 15 of the FCC Rules. Operation is subject to the following two conditions:

1. This device may not cause harmful interference.
2. This device must accept any interference received, including interference that may cause undesired operation.

Note:

This equipment has been tested and found to comply with the limits for a Class B digital device, pursuant to Part 15 of the FCC Rules. These limits are designed to provide reasonable protection against harmful interference in a residential installation. This equipment generates, uses, and can radiate radio frequency energy and, if not installed and used in accordance with the instructions, may cause harmful interference to radio communications. However, there is no guarantee that interference will not occur in a particular installation. To determine if the equipment is interfering with radio or television reception, remove or apply power to the equipment and observe if the interference goes away, or returns, when the unit is off or on. The user is encouraged to try to correct the interference by one of the following measures:

- Reorient or relocate the receiving antenna.
- Increase the separation between the equipment and receiver.
- Connect the equipment into an outlet on a circuit different from that to which the receiver is connected.
- Consult KVH for assistance.

IMPORTANT:

- To meet FCC requirements, shielded Ethernet cables are required to connect the Hub to the ship's network.
- This equipment contains no user serviceable parts. Opening this unit will violate the warranty and may result in this equipment no longer complying with FCC requirements for Class B digital devices.





www.kvh.com



KVH Industries A/S
EMEA Headquarters
Birkerød, Denmark
Tel: +45.45.160.180 Fax: +45.45.160.181
Email: info@emea.kvh.com

KVH Industries, Inc.
World Headquarters
Bristol, RI U.S.A.
Tel: +1.401.847.3327 Fax: +1.401.849.0045
Email: info@kvh.com

KVH Industries Pte Ltd.
Asia-Pacific Headquarters
Singapore
Tel: +65.6513.0290 Fax: +65.6472.3469
Email: info@apac.kvh.com