

**KVH Industries, Inc.**

# TracVision® HD7



**Installation Guide**

# TracVision HD7 Installation Guide

These instructions explain how to install the TracVision® HD7 satellite TV antenna system (with the alternate, 35" (90 cm) dome) on a vessel. Complete instructions on how to use the system are provided in the User's Guide.

---

## Installation Steps

1. Inspect Parts and Get Tools .....	3	11. Connect the Antenna Cables.....	13
2. Plan the Antenna Installation .....	4	12. Connect Power .....	14
3. Plan the ACU Installation .....	5	13. Connect SWM Receivers/DVRs.....	16
4. Prepare the Antenna Site.....	6	14. Configure SWM Receivers/DVRs.....	17
5. Remove the Hatch and Radome.....	7	15. Connect to An Onboard Network.....	18
6. Prepare the RF Cable(s) .....	8	16. Access the Web Interface .....	19
7. Wire the Antenna .....	9	17. Change Network Settings.....	20
8. Mount the Antenna .....	10	18. Update the System Software.....	21
9. Remove the Shipping Restraints .....	11	19. Educate the Customer.....	22
10. Mount the ACU .....	12		

## Appendices

A. Wiring Non-SWM Receivers.....	23	C. ACU Menu Structure .....	28
B. Configuring Non-SWM Receivers ....	26		

---

## Who Should Install the System?

To ensure a safe and effective installation, KVH recommends that a KVH-authorized marine technician install the TracVision antenna. KVH-authorized technicians have the tools and electronics expertise necessary to install the system. To find a technician near you, visit [www.kvh.com/wheretogetservice](http://www.kvh.com/wheretogetservice).

---

## Technical Support

If you need technical assistance, please contact KVH Technical Support:

Phone: +1 401 847-3327

Email: [support@kvh.com](mailto:support@kvh.com)

(Mon.-Fri., 9 am-6 pm Eastern)

(Sat., 9 am-2 pm Eastern)



# 1 Inspect Parts and Get Tools

Before you begin, follow the steps below to ensure you have everything needed to complete the installation.

- a. Unpack the box and ensure it contains everything shown on the Kitpack Contents List. Save the packaging for future use.

**IMPORTANT!**

Always lift the antenna by the baseplate and never by the radome or any portion of the internal antenna assembly (see [Figure 1](#)).

- b. Carefully examine all of the supplied parts to ensure nothing was damaged in shipment.
- c. Gather the tools and materials listed below. You will need these items to complete the installation.

- #0 Flat-head screwdriver
- #1 Phillips screwdriver
- #2 Phillips screwdriver
- Electric drill and 1/2" (1.3 cm) drill bit
- 2" (5 cm) hole saw
- 17 mm nut driver or wrench
- 5/8" open-end wrench
- 9/16" nut driver or wrench
- 7/16" open-end wrench
- Light hammer and center punch
- Wire strippers and terminal lug crimper
- Cutting pliers
- RG-6 or RG-11 RF coax cabling with Snap-N-Seal® F-connectors; refer to Step 4 on [page 8](#) for details
- Satellite TV receivers and/or DVRs
- Surge protector or uninterruptible power supply (UPS) (recommended)
- Silicone sealant, self-vulcanizing tape, or equivalent

Figure 1 TracVision HD7 Antenna

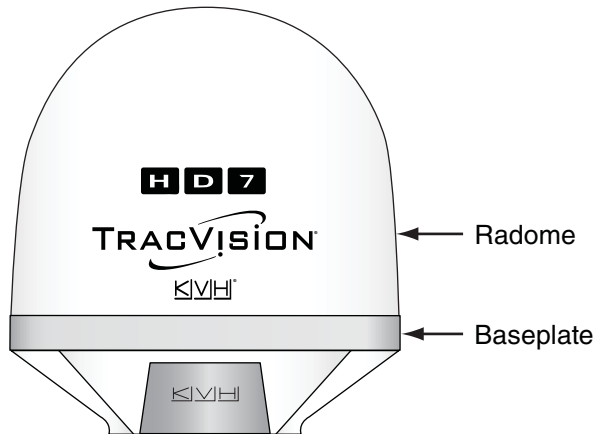

Figure 2 Antenna Control Unit (ACU)



# 2 Plan the Antenna Installation

Before you begin, consider the following antenna installation guidelines:

- The antenna must be mounted outside the radar's beam pattern.

**IMPORTANT!**

Do not mount the antenna at the same level as the radar because the radar's energy will overload/damage the antenna's LNB.

- Minimize blockage. The antenna requires a clear view of the sky to receive satellite TV (see Figure 3). The fewer obstructions, the better the system will perform.
- Make sure the mounting surface is wide enough to accommodate the antenna's base (see Figure 4). Also make sure it is flat, level (within  $\pm 1^\circ$ ), strong enough to support the antenna's weight (95 lbs (43 kg)), and rigid enough to withstand vibration.
- Select a location that is as close as possible to the intersection of the vessel's fore-and-aft centerline and midships.
- The antenna must be located within 100 ft (30 m) of the ACU.

Figure 3 Blockage from Obstruction

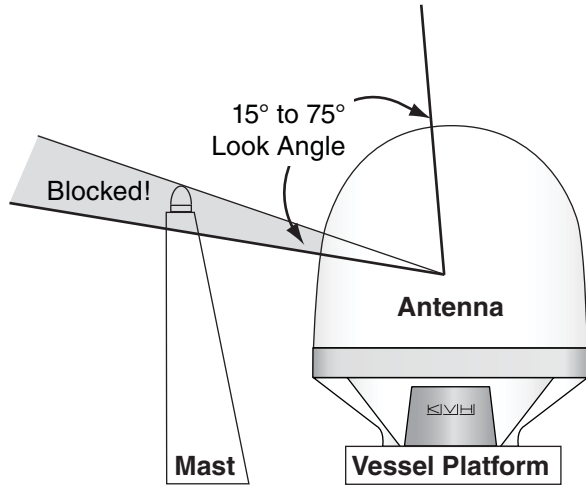
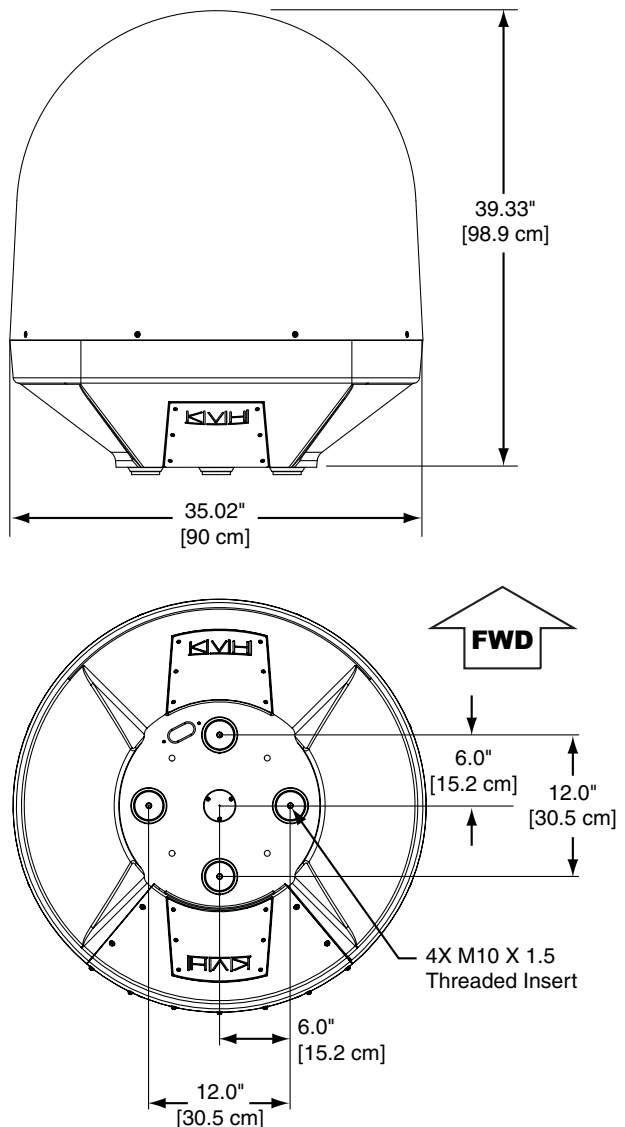

Figure 4 Antenna Dimensions



# 3 Plan the ACU Installation

Before you begin, consider the following ACU installation guidelines:

- Select an ACU mounting location in a dry, well-ventilated area belowdecks away from any heat sources or salt spray.
- Be sure the ACU's front panel will be easily accessible to the user.
- Leave enough room at the rear panel to accommodate the connecting cables.

The ACU must be located within 100 ft (30 m) of the antenna to use the supplied cables. However, you can order 150 ft (45 m) cables if a longer cable run is necessary (KVH part nos. 32-0510-0150 and 32-0619-0150).

Figure 5 ACU Dimensions

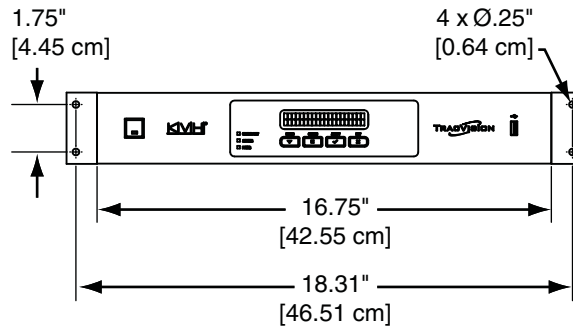
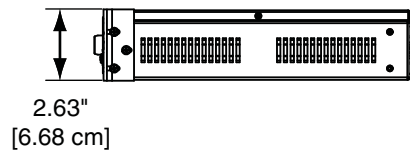
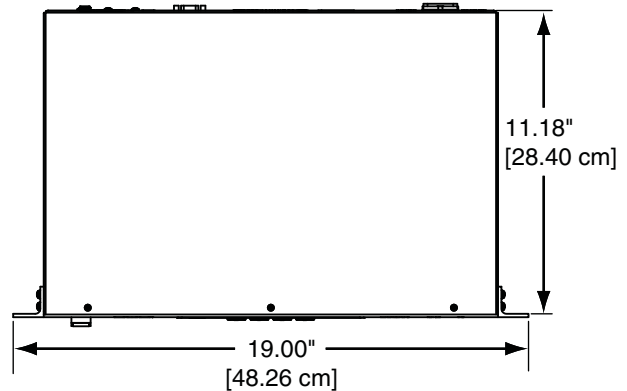

# 4 Prepare the Antenna Site

Follow the steps below to drill the antenna's mounting holes and cable access hole. You will route all of the antenna cables through this access hole later.

- Unfold the antenna mounting template (supplied in the Customer Welcome Kit) and place it onto the mounting surface. Make sure the "FWD" (forward) arrow points toward the bow and is parallel to the vessel's centerline (see [Figure 6](#)).
- Using a light hammer and center punch, mark the locations for the four mounting holes and cable access hole on the mounting surface in the locations indicated on the template.
- Drill a 1/2" (1.3 cm) hole at the four mounting hole locations. Later, you will insert four 3/8"-16 bolts through these holes to secure the antenna to the mounting surface.
- Using a 2" (5 cm) hole saw, cut out the cable access hole. Smooth the edges of the hole to protect the cables. Later, you will route the cables through this hole and into the vessel.
- Clean and dry the antenna mounting surface.
- Peel off the paper backing from the supplied foam seal to expose the adhesive.
- Press the foam seal down firmly onto the mounting surface (not the antenna's baseplate), ensuring the hole in the foam seal aligns with the cable access hole in the mounting surface (see [Figure 7](#)).

**NOTE:** Apply the foam seal to the vessel mounting surface, not to the antenna's baseplate. You will have difficulty connecting the cables to the antenna if the foam seal is attached to the baseplate.

Figure 6 Antenna Mounting Holes Layout

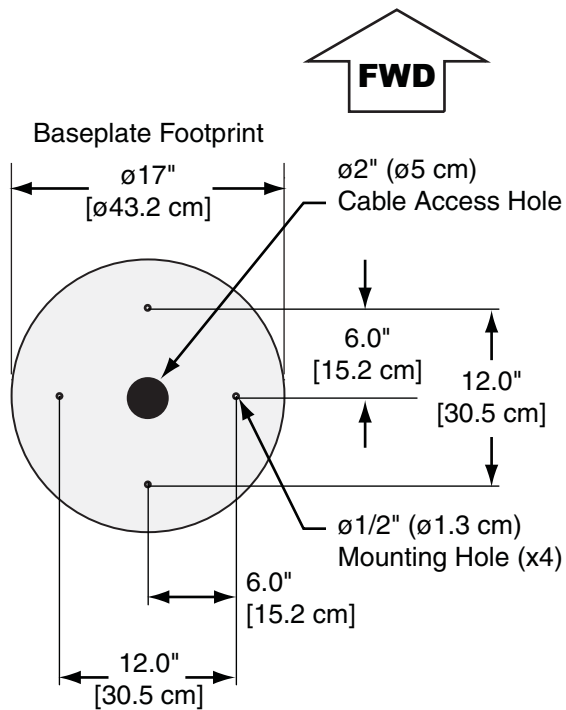
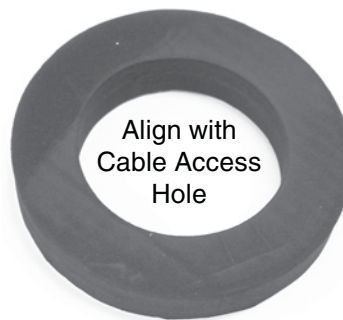

Figure 7 Foam Seal



# 5 Remove the Hatch and Radome

## Remove the Service Hatch and Radome

Follow the steps below to remove the service hatch and radome.

- a. Using a #2 Phillips screwdriver, remove the eleven M4 screws securing the service hatch to the antenna's baseplate (see [Figure 8](#)). Set the hatch aside in a safe place.
- b. Using a #2 Phillips screwdriver, remove the eight #10-32 Phillips screws securing the radome to the baseplate (see [Figure 9](#)).
- c. Carefully lift the radome straight up off the antenna. Then set it aside in a safe place.

**TIP:** If you keep the radome topside, secure it with a lanyard to prevent it from falling overboard.

Figure 8 Service Hatch Screws

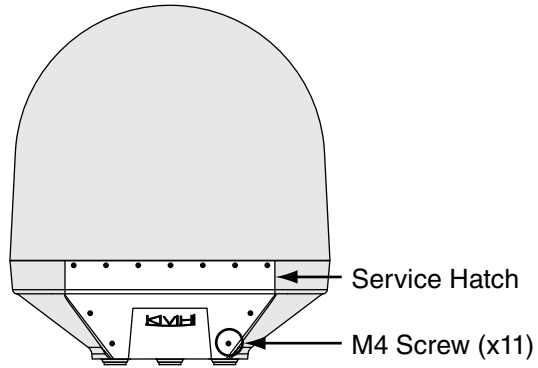
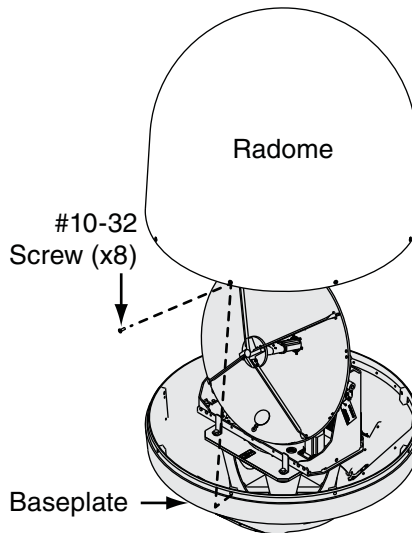

Figure 9 Radome Screws



# 6 Prepare the RF Cable(s)

Follow the steps below to prepare the antenna's RF cable(s).

## DIRECTV SWM Devices: 1 RF Cable

If you are installing **only** DIRECTV® SWM receivers and DVRs, you only need to run a single RF cable from the antenna to the SWM power inserter belowdecks. Some SWM-compatible receivers/DVRs are listed in [Figure 10](#).

*NOTE: Additional SWM-compatible receivers/DVRs might become available at any time. If your receiver or DVR model is not listed here, check its manual to see if it is SWM-compatible.*

## Non-SWM Devices: 3 RF Cables

If you plan to install any non-SWM receivers or DVRs, you need to run three RF cables: one RF cable from the antenna to the SWM power inserter, and two RF cables from the antenna to a multiswitch. Non-SWM receivers/DVRs include DIRECTV Latin America, DISH Network, Bell TV, and legacy DIRECTV receivers not listed in [Figure 10](#).

## Prepare the RF cables

Refer to [Figure 11](#) to determine the type of RF cable(s) and connectors required for your cable run between the antenna and belowdecks equipment. Then prepare the cable(s) as described below.

### IMPORTANT!

- RF cables must be rated for 75Ω, not 50Ω.
- Low-quality, poorly terminated, or improperly installed RF cables are the most common cause of system problems. Terminate all RF cables with high-quality "F" connectors using the proper stripping/crimping tools, exactly to the manufacturer's specifications.
- When determining cable lengths, be sure to account for an adequate service loop, approximately 8" (20 cm) at both ends of each cable.

Figure 10 DIRECTV SWM Receivers and DVRs

SWM Receivers	SWM DVRs
H20	HR21, HR21 Pro
H21	HR22
H22	HR23
H23	HR24
H24	HR34/HMC
H25	HR44
D12	R16
D13	R20
	R22
	R23

Figure 11 RF Cable Requirements

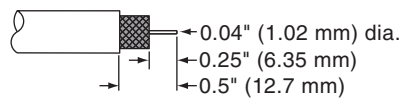
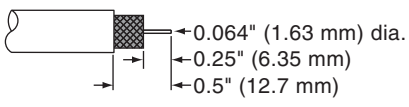
Up to 100 ft (30 m) Cable Run	
Cable	RG-6 (KVH part no. 32-0417-100)
Connector	Belden SNS1P6 (KVH part no. 23-0170)
Tools	Augat IT1000 (KVH part no. 19-0242)
Strip Lengths	
Up to 200 ft (31-60 m) Cable Run	
Cable	RG-11 (KVH part no. 32-1272-200)
Connector	Belden SNS11AS (KVH part no. 23-0213)
Tools	Belden CST596711, L3011B (KVH part no. 72-0493)
Strip Lengths	

# 7 Wire the Antenna

Follow the steps below to connect the antenna cables.

## Connect the Power and Data Cables

Connect the supplied data and power cables to the antenna (see [Figure 12](#)). Hand-tighten until the connectors lock in place; do not use excessive force.

*NOTE: Longer cables are available from KVH (see [Figure 13](#)).*

## Connect the RF Cable(s)

- Clean and dry the connectors on the RF cable(s) and the antenna (see [Figure 12](#)).
- Fill half of the inner body of an RF cable's connector with the supplied silicone grease.
- Connect and **SLOWLY** hand-tighten the RF cable to the antenna's SWM (RF1) connector, allowing the grease to diffuse and settle into the entire space within the connector.
- Make sure the RF cable is tightened all the way into the connector. Then tighten it with a 7/16" torque wrench set to 20 in.-lbs.
- Wipe off any excess grease from the outside of the connector.
- Seal the connection with silicone sealant or equivalent.
- If you plan to install any non-SWM devices, repeat steps b-f to connect additional RF cables to the RF3 and RF4 connectors. RF2, RF3, and RF4 all provide the same output - you may select any two.

## Route the Cables Belowdecks

- If you connected more than one RF cable, label the ends of the cables for easy identification belowdecks.
- Route all cables belowdecks through the cable access hole. Leave an adequate service loop, approximately 8" (20 cm) of slack, in the cables for easy serviceability. Also maintain the minimum bend radius in the RF cables throughout the cable run (see [Figure 14](#)).
- Weatherproof and seal the cable access hole, as required.

Figure 12 Antenna Connectors

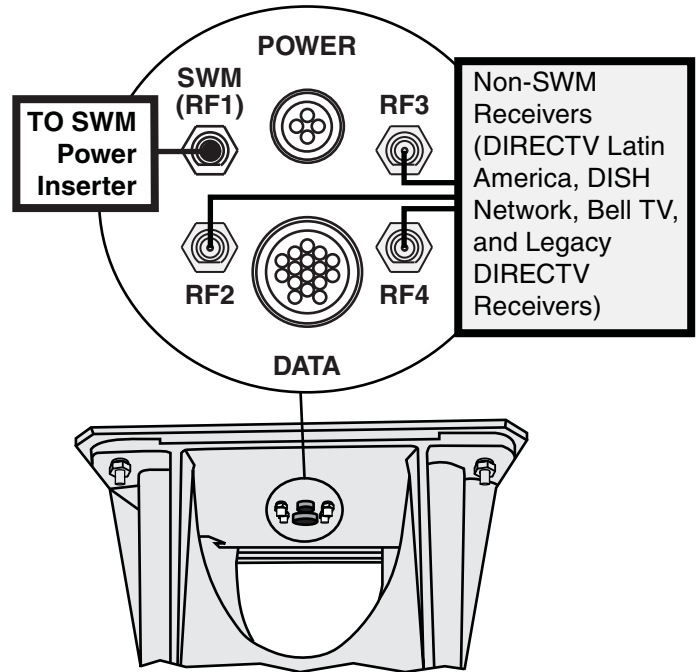

Figure 13 Longer Data and Power Cable Options

Length	Type	Part Number
150 ft (45 m)	Data	S32-0619-0150
	Power	S32-0510-0150
200 ft (60 m)	Data	S32-0619-0200
	Power	S32-0510-0200

Figure 14 Minimum Bend Radius of RF Cables

Cable Type	Minimum Bend Radius
RG-6	3" (7.6 cm)
RG-11	4.5" (11.5 cm)

# 8 Mount the Antenna

Follow the steps below to mount the antenna to the mounting surface.

- Place the antenna baseplate over the holes drilled in the mounting surface.
- Ensure the forward arrow inside the baseplate points toward the bow and is parallel to the vessel's centerline (see [Figure 15](#)).

## **IMPORTANT!**

If necessary, rotate the antenna assembly by hand to see all four mounting holes. Rotate the antenna assembly slowly to avoid damaging the antenna.

- At each of the four baseplate mounting holes, place an M10 lock washer and flat washer on an M10 bolt and insert the bolt into the hole from below (see [Figure 16](#)).
- Tighten all four bolts until the four rubber feet on the baseplate are bottomed against the mounting surface and the foam seal is fully compressed. KVH recommends that you tighten the bolts to between 12 and 16 ft-lbs (16.2 and 21.7 N-m) of torque. Internal restraints prevent the antenna assembly from moving during shipment.

Figure 15 Forward Arrow Location

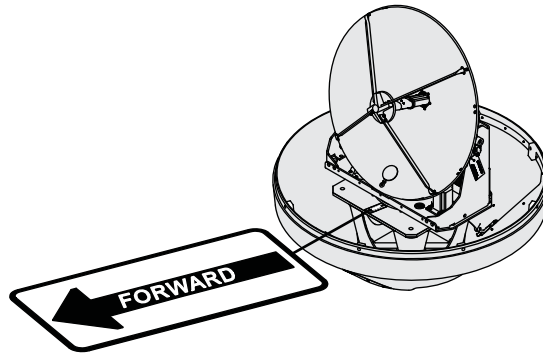
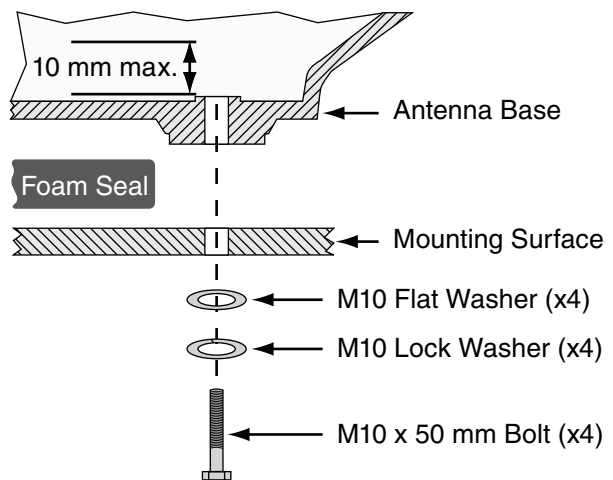

Figure 16 Antenna Mounting



# 9 Remove the Shipping Restraints

## Remove the Shipping Restraint Brackets

Internal shipping restraint brackets prevent the antenna assembly from moving during shipment. Using a 9/16" nut driver or wrench, remove the two 3/8" bolts, washers, and lock nuts securing the two brackets (see [Figure 17](#)).

*NOTE: Be sure to keep the brackets for future use.*

## Reinstall the Mounting Bolts

Follow the steps below to reinstall the bolts securing the antenna assembly to the internal mounting platform.

- Place a 3/8" flat washer (supplied in the kitpack) on the two 3/8" bolts that you just removed (see [Figure 17](#)).
- Reinstall the bolts and secure in place with the washers and lock nuts you removed earlier (see [Figure 18](#)).

## Remove the Shipping Restraints

Using cutting pliers, cut and remove the tie-wrap and wire equipped with paper tags (see [Figure 19](#)).

## Reinstall the Radome and Add Screw Caps

- Reinstall the radome and access hatch onto the antenna. Secure the radome and hatch in place using the screws you removed in ["Remove the Hatch and Radome"](#) on page 7.
- Install a plastic screw cap (supplied in the kitpack) over the eight radome screws.

Figure 17 Shipping Restraint Bracket Removal

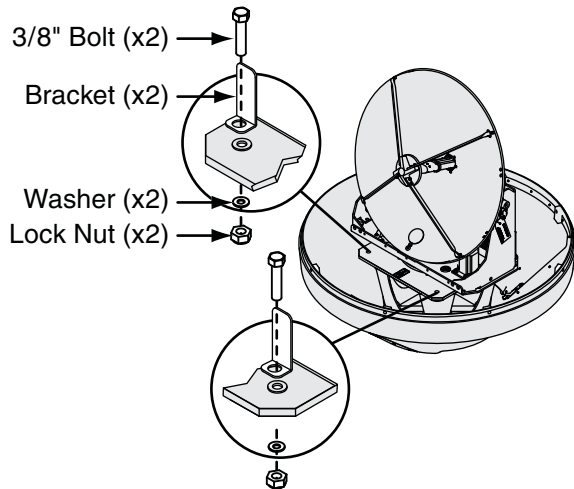

Figure 18 Mounting Bolt Reinstallation

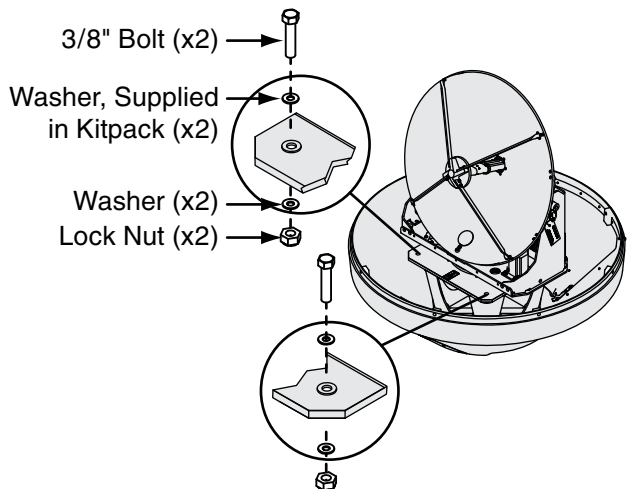
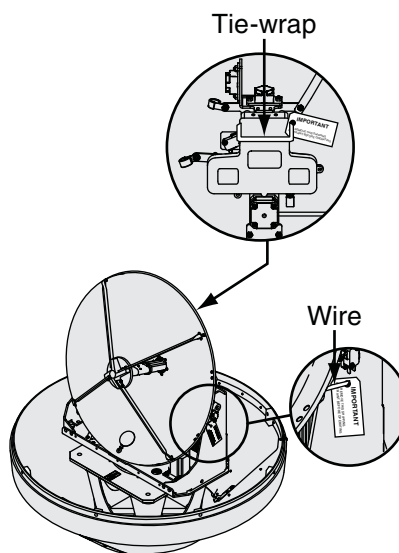

Figure 19 Shipping Restraints



# 10 Mount the ACU

There are two options for mounting the ACU:

**Option 1** - Inside an equipment rack

**Option 2** - To a horizontal surface

*NOTE: You may choose to wait to mount the ACU until after you have completed all system wiring.*

## Option 1 - Rack Mount

The ACU is sized to fit a standard 19" (48.26 cm) rack, occupying 1.5U of space. Follow these steps to secure the ACU in an equipment rack.

- a. Insert the ACU into the rack and align the four mounting holes on the front panel of the ACU to the mounting holes on the equipment rack.
- b. Secure the ACU to the equipment rack using four M6 screws and washers (see [Figure 20](#)).

## Option 2 - Horizontal Surface Mount

Follow these steps to mount the ACU to a horizontal surface. You may secure it underneath or on top of a horizontal surface using the supplied brackets.

- a. Remove the six screws securing the rack mounting brackets to the sides of the ACU (see [Figure 21](#)).
- b. Secure the mounting brackets to the sides of the ACU using four supplied #6-32 screws and washers (see [Figure 22](#)). You can attach the brackets at either the top or the bottom of the ACU, depending on your desired mounting orientation.
- c. Secure the ACU to the mounting surface using fasteners that are appropriate for the surface.

Figure 20 ACU Equipment Rack Mounting

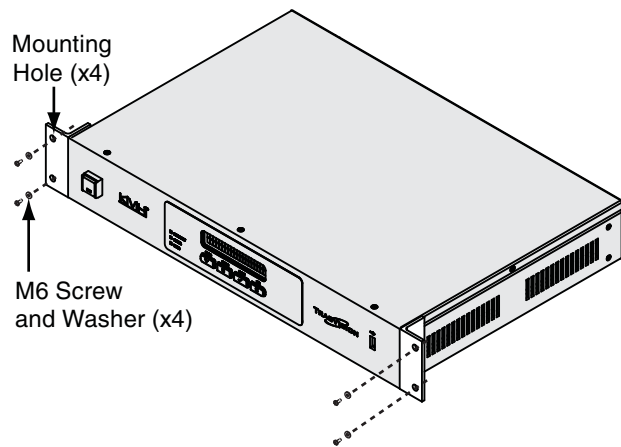

Figure 21 ACU Rack Mounting Bracket Removal

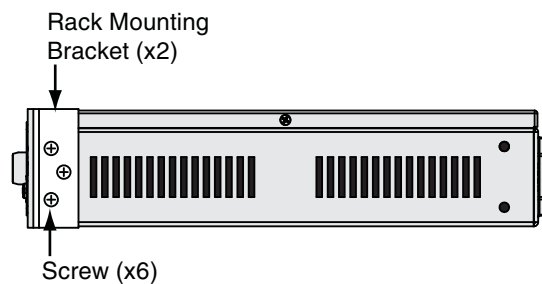
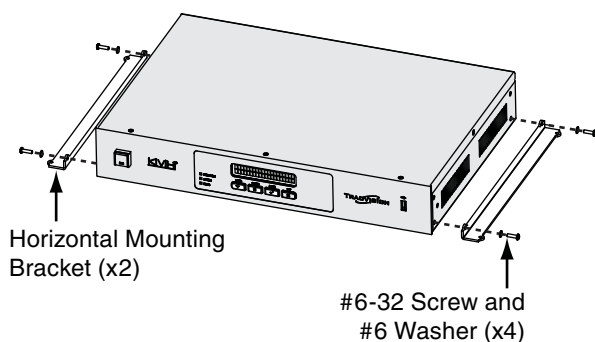

Figure 22 ACU Horizontal Surface Mounting



# 11

## Connect the Antenna Cables

Follow the steps below to connect the antenna's power, data, and RF cables to the belowdecks equipment.

### Connect Antenna Power and Data Cables

- Connect the antenna's data cable wires to the terminal strip connector (supplied in the kitpack), as shown in [Figure 23](#). Tighten each terminal screw to secure the wires in place.

#### **IMPORTANT!**

The diagram refers to wires by **body color/stripe color**. For example, "Brown/White" means the brown wire with white stripe.

- Connect the antenna's power cable wires to the terminal strip connector, as shown in [Figure 23](#). Tighten each terminal screw to secure the wires in place.
- Plug the terminal strip connector into the rear panel of the ACU (see [Figure 23](#)).

### Connect Antenna SWM (RF1) Cable

- Connect the antenna's SWM (RF1) cable to the power inserter's SWM connector (see [Figure 24](#)).
- Using fasteners appropriate for the mounting surface, secure the power inserter to the mounting surface.

### Connect Antenna RF3 and RF4 Cables (Optional)

If you are installing non-SWM receivers and/or DVRs, connect the antenna's RF3 and RF4 cables to an active (powered) multiswitch, as shown in ["Wiring Non-SWM Receivers"](#) on page 23.

Figure 23 Antenna Power and Data Wiring

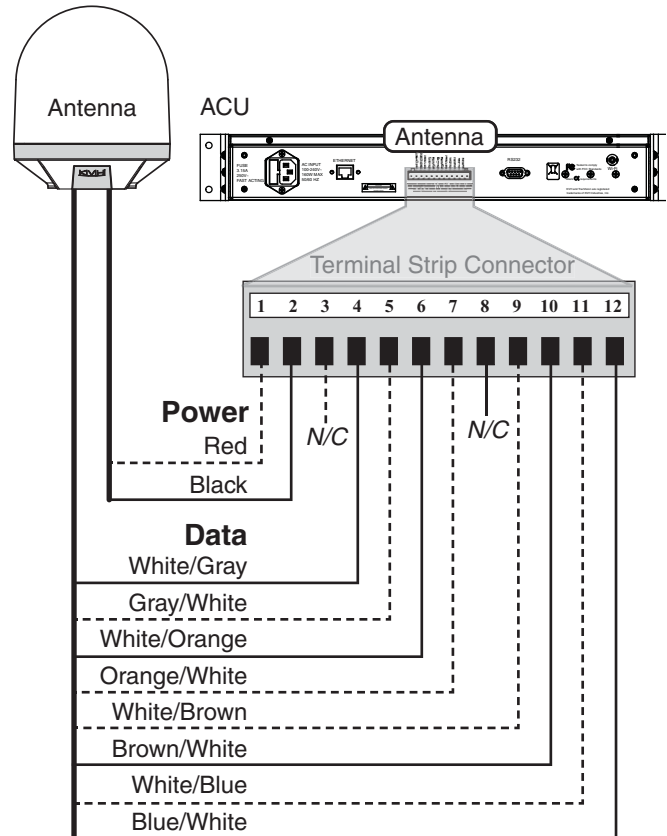

Two unused wires; N/C = Not Connected

Figure 24 Antenna SWM (RF1) Wiring

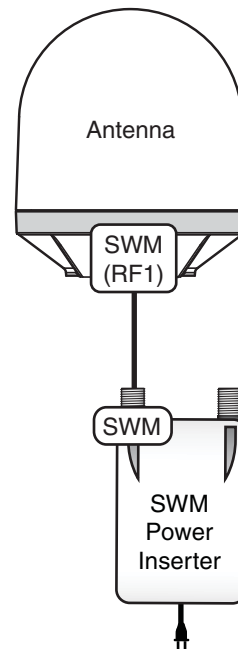

# 12 Connect Power

Before you begin, be sure that you understand the following important requirements.

## AC Power Requirements

The TracVision system is designed to run on 3-wire single-phase AC power (hot, neutral, and ground). Voltage between hot-neutral and hot-ground should each measure between 100-240 VAC.

Many large ships use two-phase, split-phase, or delta power instead (3 wires: hot, hot, and ground; no neutral). In this case, voltage between hot-hot measures the proper voltage (100-240 VAC); while hot-ground measures only half the voltage (50-120 VAC). Although the TracVision system can operate on this type of power, the excess voltage present on the second phase will cause a small amount of current to leak onto ship's ground. This leakage current might be unacceptable on some vessels, so check with the customer or ship's electrician and get permission before you run the system on two-phase power. Also be sure to ground the system, as explained in ["Grounding Requirements"](#) on page 15.

If two-phase power is the only available power source onboard, and if leakage current is unacceptable, KVH recommends that you install a suitable isolation transformer to supply single-phase power to the antenna system and run a ground wire from the transformer to ship's ground. In addition, since ground fault protection devices cannot detect faults behind a transformer, you will also need to install a ground fault monitoring device between the isolation transformer and the antenna system if ground fault protection is required on the vessel.

**NOTE:** Consider installing an uninterruptible power supply (UPS) to avoid interruptions during power outages and transitions to/from shore power.

Figure 25 AC Power Options

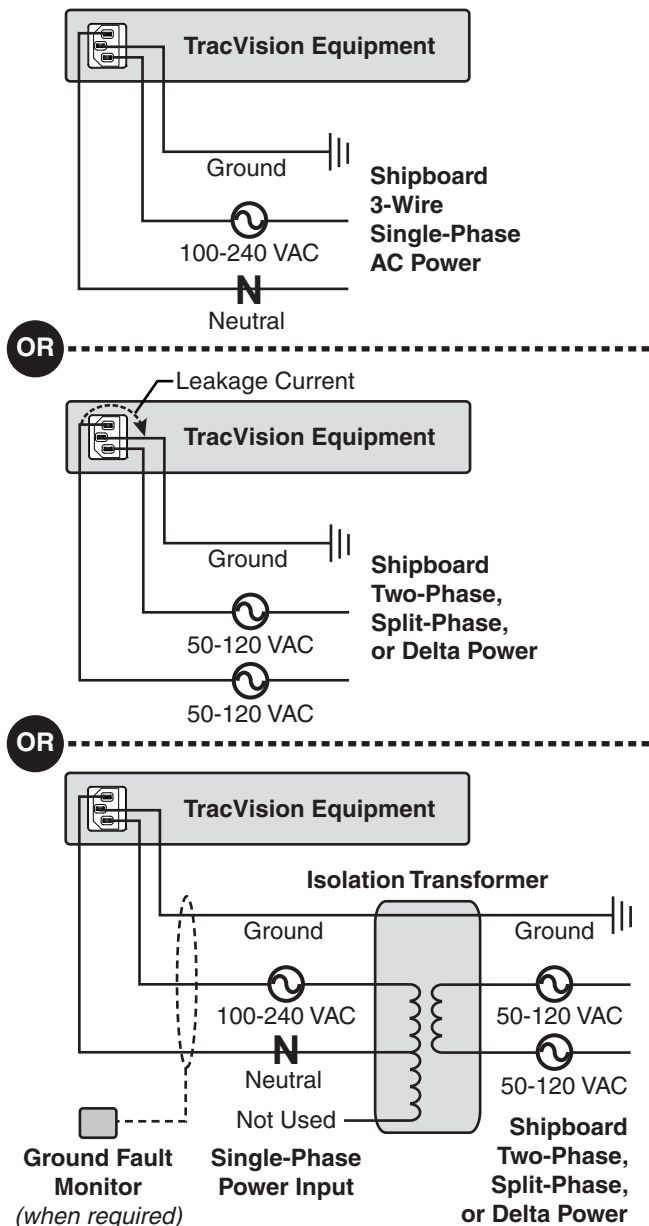

# 12 Continued Connect Power

## Grounding Requirements

Proper grounding of the TracVision system to ship's ground is critically important, as it protects the equipment from lightning and electrostatic discharges (ESD).

In a standard installation with a connection to single-phase AC power, the antenna system is normally connected to ship's ground through the ground wire of the ACU's power plug. As an alternative, you may run a separate ground wire from the ACU's chassis to ship's ground, or mount the equipment within a grounded equipment rack.

Figure 26 Power Wiring

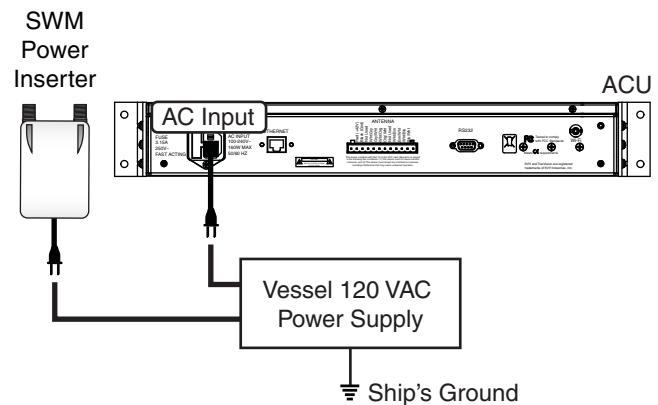

### WARNING

**Failure to ground the TracVision system properly to ship's ground will cause an unsafe floating ground condition, risking damage to the antenna and electric shock, potentially resulting in DEATH.** In a floating ground condition, the difference between the equipment's chassis ground and the ship's ground can measure well over 100 volts, when it normally should not exceed 25 volts. Therefore, always measure the difference in potential between chassis ground and ship's ground to make certain that there is no dangerous floating ground condition, even if the ground pin of the vessel's AC power plug appears to be intact.

## Connect Power to the System

Follow the steps below to connect power to the TracVision system.

- Before you begin, disconnect vessel power and be sure the vessel is properly grounded in accordance with marine standards.
- Connect the supplied AC power cord to the ACU (see [Figure 26](#)).
- Plug the ACU's power cord and the SWM power inserter's power cord into the vessel's 120 VAC power supply. Although the ACU can run on 240 VAC, the SWM power inserter is only rated for 120 VAC.

# 13 Connect SWM Receivers/DVRs

Follow the steps below to connect the customer's DIRECTV SWM receiver(s) and/or DVR(s) to the system.

**NOTE:** If you need to install a non-SWM receiver or DVR, refer to "Wiring Non-SWM Receivers" on page 23.

- a. Using the screws supplied with the 8-way SWM splitter, secure the splitter to an appropriate mounting surface.
- b. Fasten one end of the supplied 25 ft (30 m) ground wire to the splitter's grounding screw. Connect the other end to a suitable AC ground (see Figure 27).
- c. Connect an RF cable from the power inserter's IRD connector to the splitter's In connector (see Figure 27).
- d. Connect the splitter to the customer's SWM devices. The splitter supports up to eight tuners. You can connect any number of SWM receivers, DVRs, and clients that add up to 8 tuners or fewer (see Figure 27).

**NOTE:** If you need more than 8 tuners, you may install an optional 16-tuner SWM expander kit (KVH part no. 72-0452-01) or 32-tuner expander kit (KVH part no. 72-0452-02).

- e. Terminate any unused connectors on the splitter with a supplied 75Ω terminator.

Figure 27 DIRECTV SWM Receiver/DVR Wiring (Example)

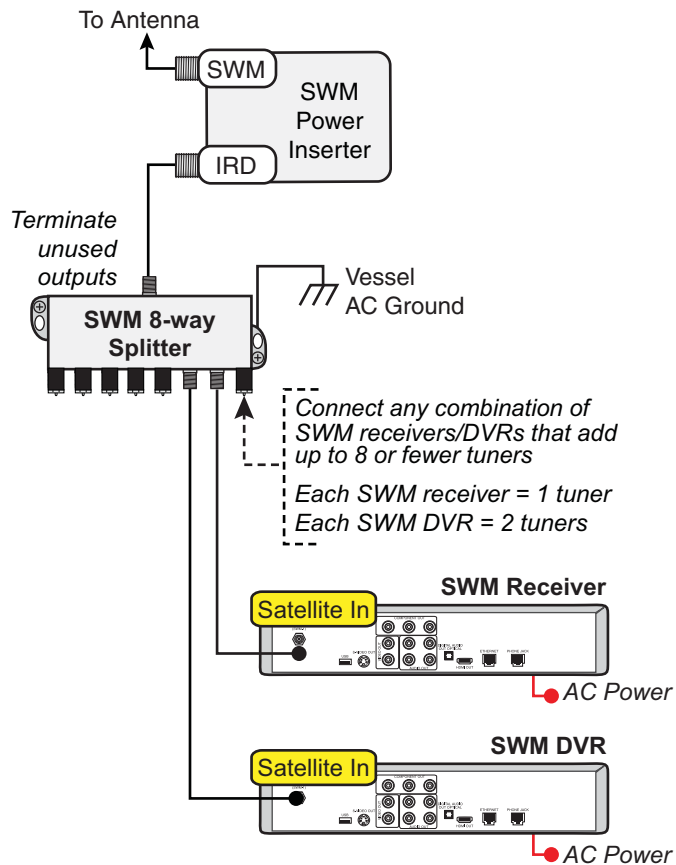

# 14 Configure SWM Receivers/DVRs

Follow the steps below to start up the TracVision system and configure each DIRECTV SWM receiver and/or DVR for TracVision use.

## IMPORTANT!

If you need to configure non-SWM devices, such as DIRECTV Latin America, DISH Network, Bell TV, or legacy DIRECTV receivers, refer to “[Configuring Non-SWM Receivers](#)” on page 26.

## Turn On the TracVision System

- Apply power to the power inserter and ACU.
- Press the power button on the front of the ACU to turn on the TracVision system (see [Figure 28](#)).
- Wait for the Tracking screen to display on the ACU (see [Figure 28](#)). This indicates system startup is complete. It might take up to three minutes.
- Plug in and turn on any connected receivers, DVRs, and televisions.

## Set Each DIRECTV SWM Receiver/DVR to Dish Type: Slimline-3

- Press the Menu button on the receiver’s/ DVR’s remote control to display its menu on the connected television.

*NOTE: Refer to your selected receiver/DVR manual for specific configuration instructions.*

- At the Satellite Dish Setup menu, set the Dish Type to **Slimline-3**. Then choose **Continue** (see [Figure 29](#)).
- Repeat this procedure for each connected receiver and DVR.

Figure 28 ACU Tracking Screen and Power Button

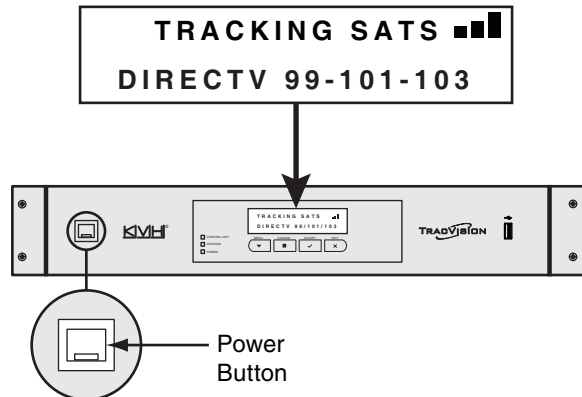
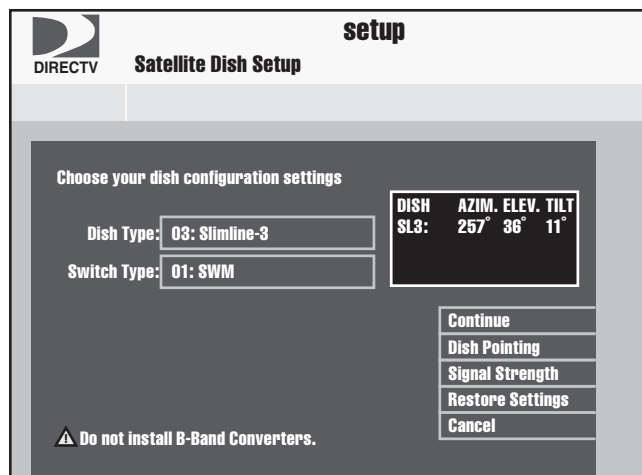

Figure 29 DIRECTV SWM Receiver/DVR Configuration



# 15

# Connect to An Onboard Network

Optional

Follow these steps to either connect the TracVision system to an existing onboard network or install the supplied wireless router to set up and connect to a new onboard network.

## Connect to An Existing Network

By default, the ACU's Ethernet port is configured as a DHCP client, which means the vessel's router can automatically assign it an IP address when connected to the ACU's Ethernet port (see [Figure 30](#)).

*NOTE: As an alternative, instead of using DHCP, you may assign a static IP address to the ACU. See "Change Network Settings" on page 20.*

## Create a New Network

Follow the instructions below to create a new onboard network using the supplied wireless router (see [Figure 30](#)).

- a. Mount the router in a cool, dry, well-ventilated area belowdecks away from any heat sources or salt spray. Also be sure the location provides adequate Wi-Fi reception. Do not install it in an area surrounded by metal or near any electrical devices that emit RF noise.
- b. Connect an Ethernet cable from one of the four numbered "Ethernet" ports on the wireless router to the "Ethernet" port on the ACU.
- c. Connect a PC or mobile device to the wireless router's default SSID network name (**Linksys<last 5 digits of the router's serial number>**).
- d. Open the web browser and enter **192.168.1.1**.
- e. Follow the router's setup wizard to complete installation.

### **IMPORTANT!**

When setting up a wireless network, KVH recommends applying security settings, such as encryption, to protect your network from outside intrusion. If your network is not secure, outsiders within range of your wireless network will be able to use your wireless connection without your knowledge.

Figure 30 Network Connection Options

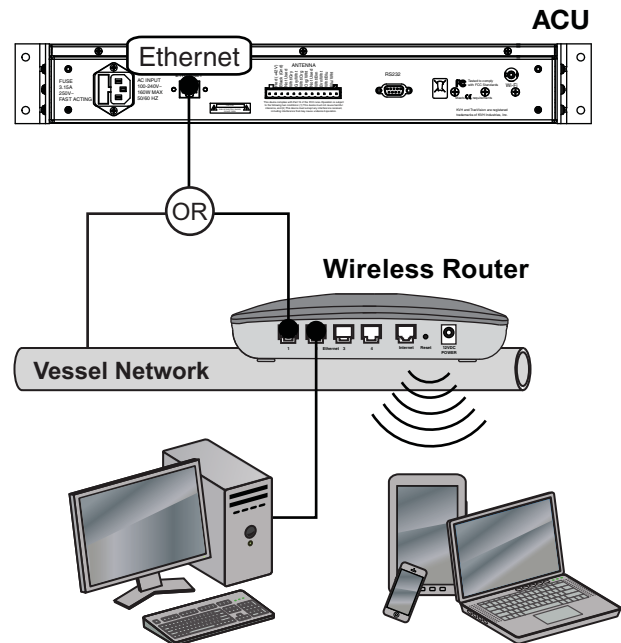

# 16 Access the Web Interface

The ACU offers a local web interface that can be used to check system status, update software, and configure all aspects of the system. Follow the steps below to access the ACU's web interface.

- a. Connect your PC or mobile device to the ACU using one of the following options:
  - Connect directly to the ACU's Ethernet port (see [Figure 31](#)).
  - Connect via the vessel network (refer to ["Create a New Network"](#) on page 18).

**NOTE:** You can find the IP address assigned to the ACU in the View Enet Settings menu on the front of the ACU (refer to ["ACU Menu Structure"](#) on page 28).

- b. Open the web browser and enter the ACU's IP address ([Figure 32](#)).

For example, if the ACU's IP address was set to 192.168.1.150, you would enter the following into the browser's address bar:

**http://192.168.1.150**

- c. Log in to the web interface using the username and password below (see [Figure 33](#)).

username: **admin**

password: **password**

Figure 31 Connection Options

Direct Connection to the ACU

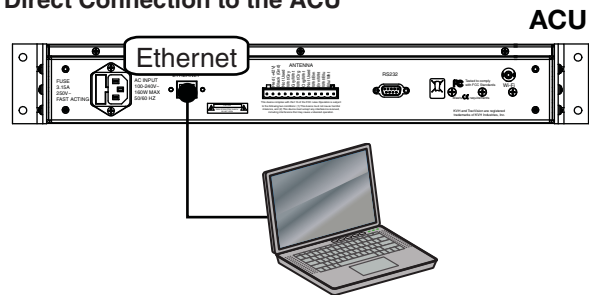

OR

Vessel Network

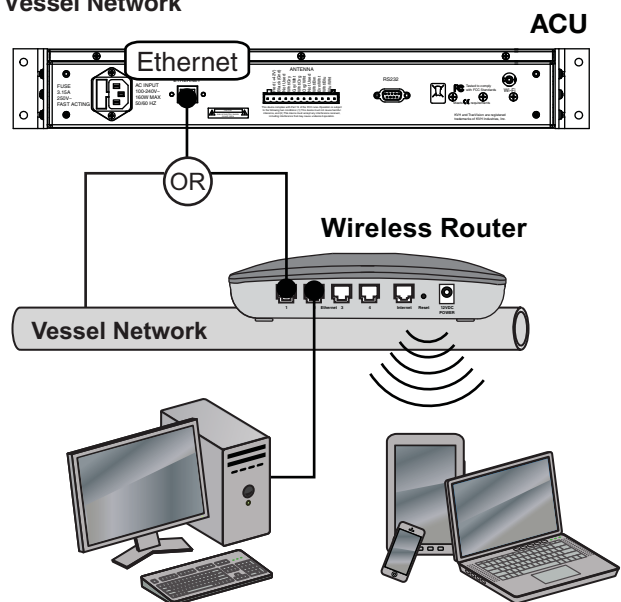

Figure 32 Entering the IP Address (Example)

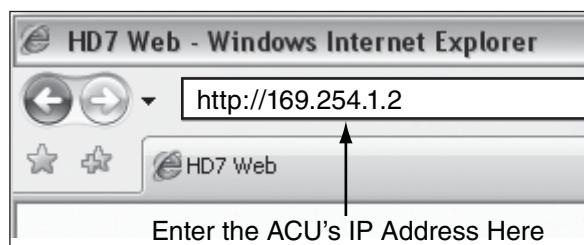
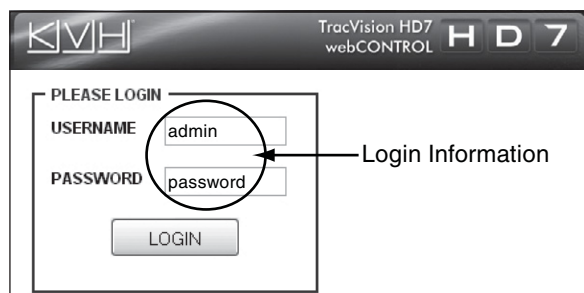

Figure 33 Web Interface Login Screen



# 17 Change Network Settings

Once your PC or mobile device is connected to the ACU's web interface, follow the steps below to change certain network settings.

## Changing Ethernet Settings

At the web interface, select the Settings tab. Then choose Edit to modify the desired network settings (see [Figure 34](#)).

*NOTE: You can also change the Ethernet settings through the View Enet Settings menu on the front of the ACU (refer to "ACU Menu Structure" on [page 28](#)).*

## Changing Wi-Fi Settings

If you are using the supplied wireless router, follow the instructions below to make changes to the router's default Wi-Fi network settings.

- a. Connect a PC or mobile device to the wireless router's default SSID network name (**Linksys<last 5 digits of the router's serial number>**).
- b. Open the web browser and enter **192.168.1.1**.
- c. Login to the router's web interface and make any necessary changes. Refer to the router's documentation for details.

Figure 34 Ethernet Settings on the Web Interface

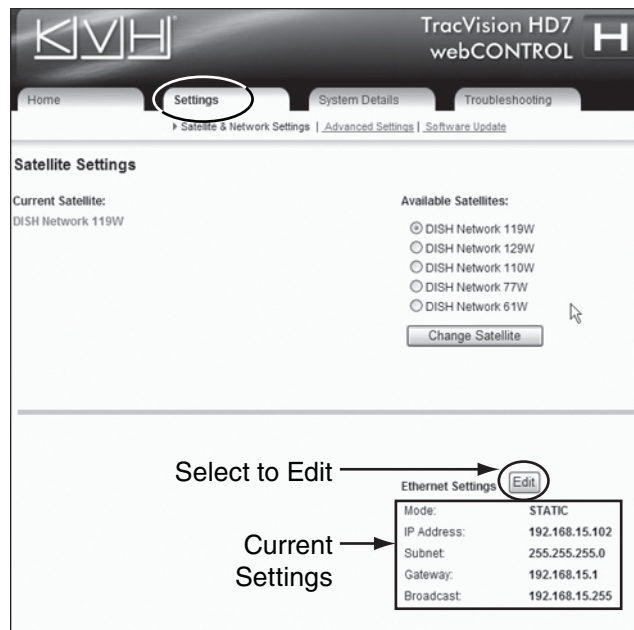

# 18 Update the System Software

Choose any of the options below to ensure the latest software is installed in the system.

**NOTE:** You can view the currently installed software version at the System Details page of the ACU's web interface. You can also view it on the ACU's front panel; go to About System > View Software Info.

## Option 1 - Use an Internet Connection

If the TracVision system is connected to the Internet, go to the ACU web interface and click **Check for Updates** (see [Figure 35](#)). Then follow the onscreen instructions to check for and install new software.

## Option 2 - Use a Laptop

If you have the new software file saved on your laptop, connect your laptop to the TracVision system via its network connection. At the Settings page of the ACU's web interface, click **Software Update** (see [Figure 36](#)). Then browse to the file stored on your laptop and click **Check File**.

## Option 3 - Use a USB Flash Drive

If you have the new software file saved on a USB flash drive, plug the flash drive into the ACU's USB port and follow the instructions on the front panel display (see [Figure 37](#)).

**NOTE:** Make sure the software update file is located in the root directory of the USB flash drive and no other .kvh file is saved on the drive.

## Option 4 - Use an iPhone® or iPod touch®

If you have the KVH TracVision HD7 application loaded on your iPhone/iPod touch, and it is configured for use with the network, follow the app's onscreen instructions to check for and install the new software (see [Figure 38](#)).

**NOTE:** You can download the app for free from the Apple iTunes® App Store.

Figure 35 ACU Check for Updates and Software Version

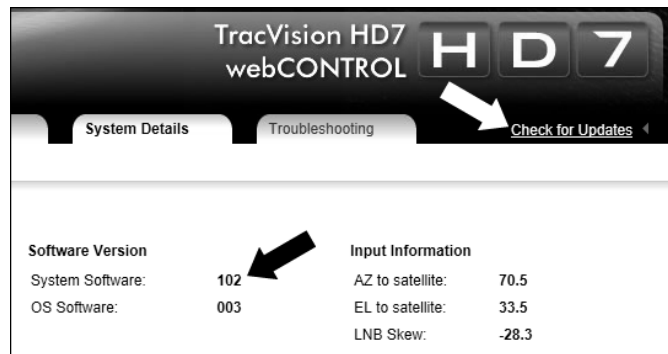

Figure 36 ACU Web Interface Software Updates Page

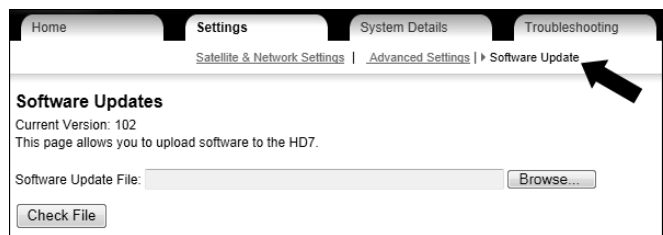

Figure 37 USB Port on ACU

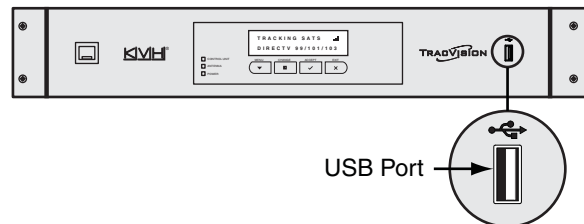

Figure 38 Software Update via iPhone or iPod touch



# 19 Educate the Customer

Before you leave the vessel, test the system to ensure the antenna works properly. Then give the Customer Welcome Kit to the customer and explain how to use the system. Ensure the customer understands the following:

- Keep the radome installed on the antenna at all times.
- The antenna must have a clear view of the sky to receive satellite TV. Common causes of blockage include bridges and boat masts.
- Heavy rain or snow might temporarily interrupt reception.
- Clean the radome regularly. Dirt buildup can affect reception.
- The vessel must be located within the satellites' coverage area to receive satellite TV signals. To view satellite coverage information, visit [www.kvh.com/footprint](http://www.kvh.com/footprint).
- KVH recommends leaving the antenna system powered on while the vessel is underway.
- Please register the system with KVH. The registration process is quick, easy, online, and ensures the best possible service from KVH. Visit [www.kvh.com/register](http://www.kvh.com/register) or refer to the Product Registration Form for details.
- You need to activate any connected receivers/DVRs for the desired satellite TV service before you can watch television. KVH can help activate a DIRECTV or DISH Network receiver/DVR; just call KVH's Activation Department at 1-866-551-8004 for DIRECTV or 1-866-399-8509 for DISH Network.
- Refer to the supplied User's Guide for operation and troubleshooting information.
- You can use the KVH TracVision HD7 iPhone/iPod touch app to communicate with the TracVision system, as long as it is connected to the vessel's onboard network. You can download the app for free at the Apple iTunes® store.

Figure 39 Example of Blockage

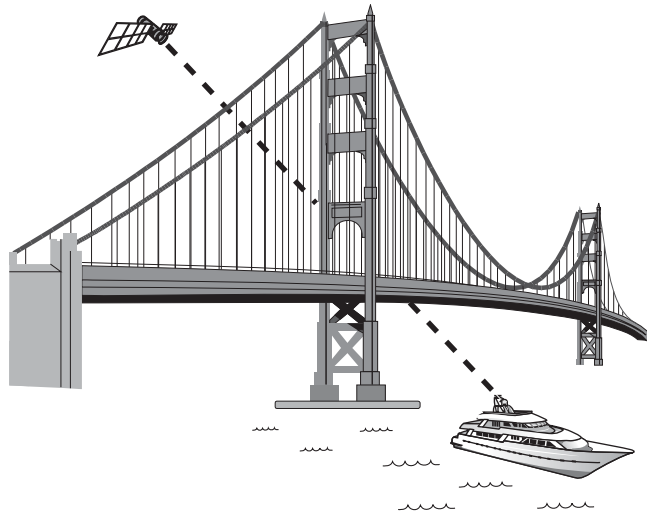

Figure 40 KVH TracVision HD7 iPhone/iPod touch App



# A Wiring Non-SWM Receivers

The following wiring diagrams show how to connect non-SWM receivers and DVRs to the system. Non-SWM receivers/DVRs include DIRECTV Latin America, DISH Network, Bell TV, and legacy DIRECTV receivers.

## Wiring Up to 4 Non-SWM Receivers

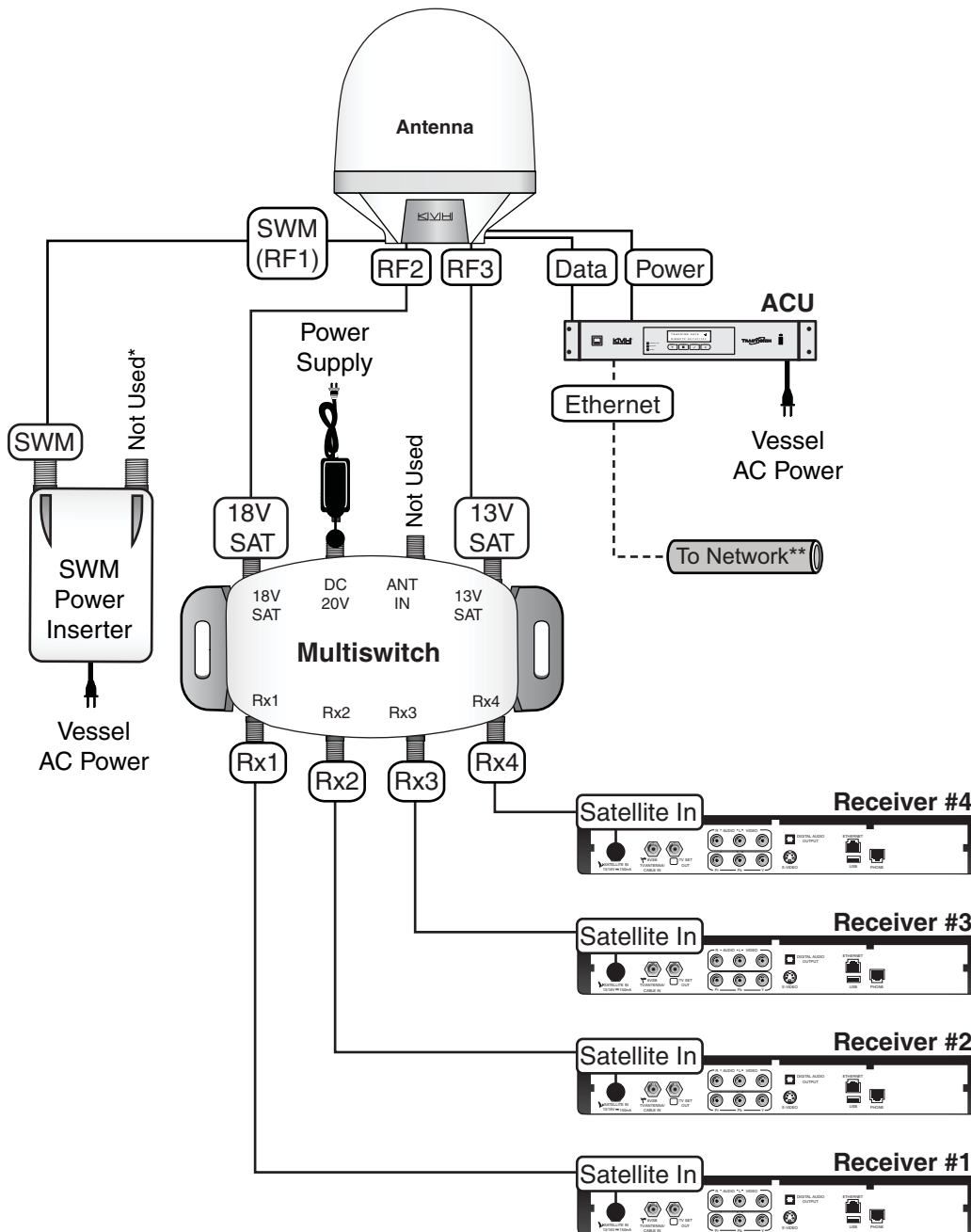

\*The supplied SWM power inserter, shown above, is required, since it supplies power to the antenna's LNB. However, this power inserter connector is not used in this configuration; it is reserved for a SWM splitter connection only.

\*\*A network connection is optional to provide easy access to the ACU's web interface.

# A

# Continued Wiring Non-SWM Receivers

## Wiring Up to 8 Non-SWM Receivers

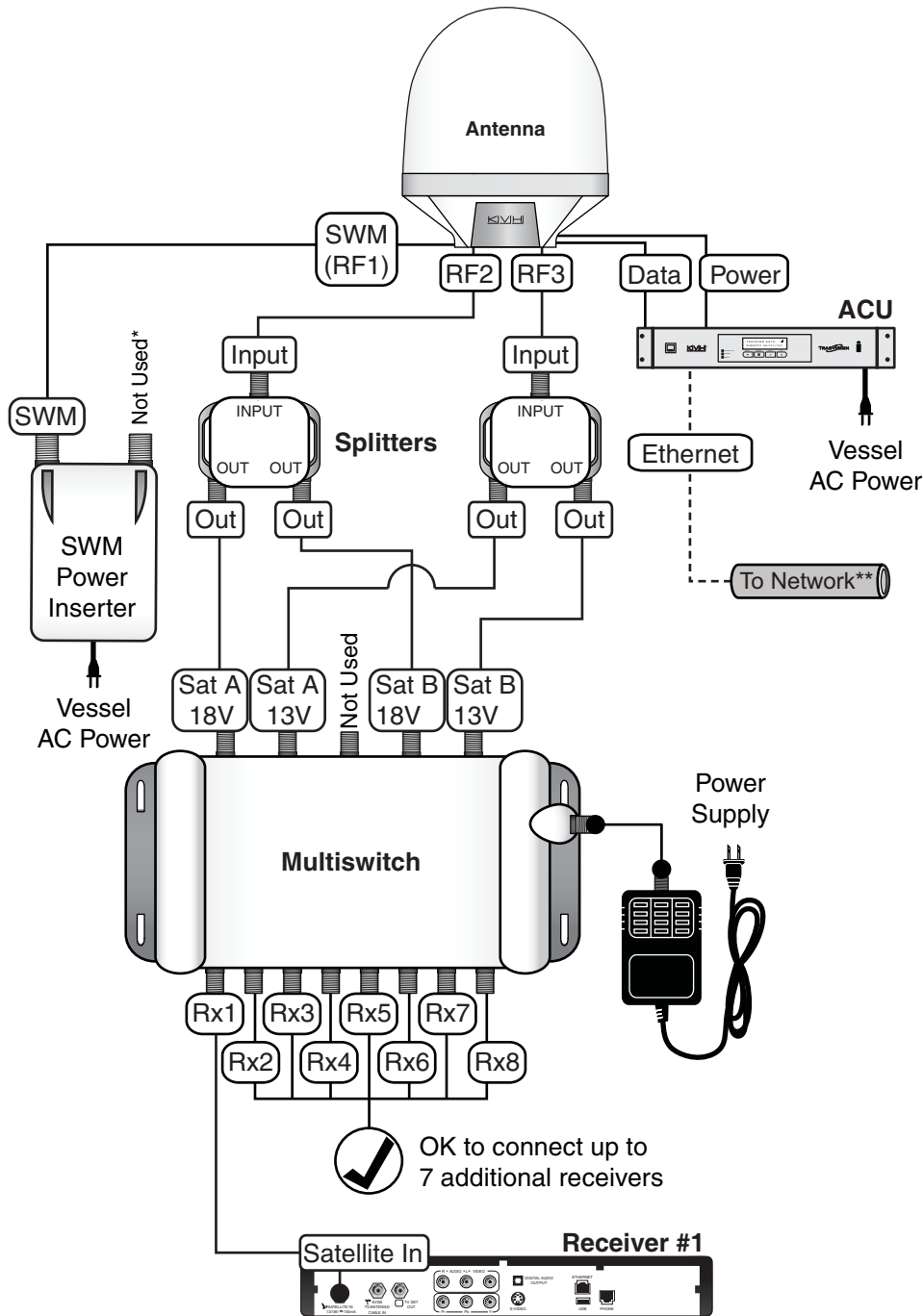

\*The supplied SWM power inserter, shown above, is required, since it supplies power to the antenna's LNB. However, this power inserter connector is not used in this configuration; it is reserved for a SWM splitter connection only.

\*\*A network connection is optional to provide easy access to the ACU's web interface.

**NOTE:** If desired, you can connect up to 16 receivers using this wiring diagram and a 16-output multiswitch.

# A

# Continued Wiring Non-SWM Receivers

## Wiring SWM and Non-SWM Receivers

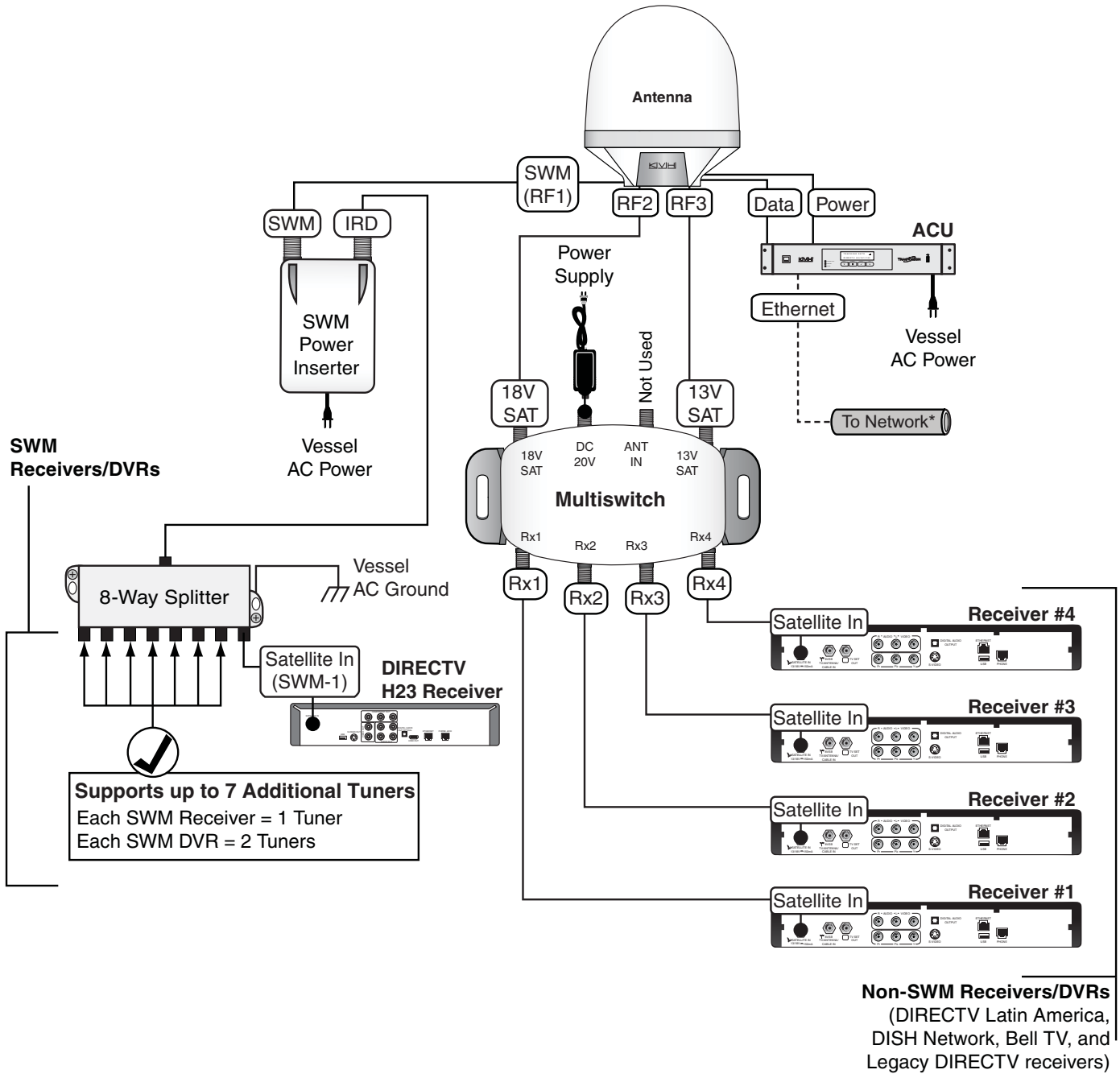

\*A network connection is optional to provide easy access to the ACU's web interface.

# B Configuring Non-SWM Receivers

Follow the steps below to set up the TracVision system to use the customer's selected satellite TV service and configure non-SWM receivers and DVRs.

### Select the Satellite TV Service on the ACU

Follow the steps below to set up the TracVision system for the customer's satellite TV service.

*NOTE: If you don't have access to the web interface, you can change the service setting at the ACU's front panel. Go to **Advanced Options > Change Sat Service**.*

- a. Using a computer connected to the same network as the HD7, open a web browser and enter the ACU's IP address.
- b. At the Login window, enter the following user name and password (see [Figure 41](#)):  
Username: **admin**  
Password: **password**
- c. At the Settings page, click **Advanced Settings** (see [Figure 42](#)).
- d. Select the desired service provider. Then click **Change Service**.

Figure 41 Web Interface Login Screen

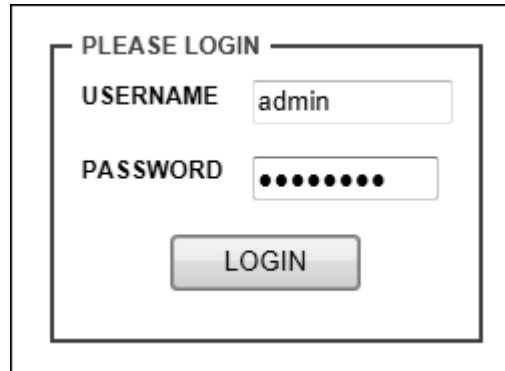

A screenshot of a web interface login screen. At the top, it says "PLEASE LOGIN". Below that are two input fields: "USERNAME" with the text "admin" and "PASSWORD" with a masked password of ten dots. A "LOGIN" button is positioned below the password field.

Figure 42 ACU Web Interface Advanced Settings Page

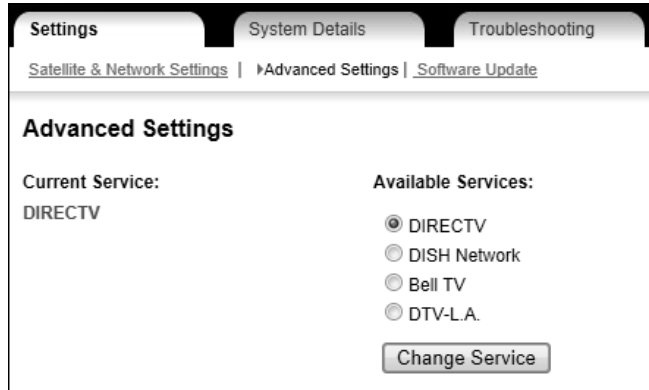

A screenshot of the ACU web interface's "Advanced Settings" page. The page has a navigation bar with "Settings", "System Details", and "Troubleshooting". Below the navigation bar, there are links for "Satellite & Network Settings", "Advanced Settings", and "Software Update". The main content area is titled "Advanced Settings" and shows "Current Service: DIRECTV" and "Available Services:" with radio buttons for "DIRECTV", "DISH Network", "Bell TV", and "DTV-L.A.". A "Change Service" button is located at the bottom right of the available services section.

# **B** Continued Configuring Non-SWM Receivers

---

## **Set Up Each Receiver/DVR**

Follow the steps below to configure non-SWM receivers/DVRs.

### **DISH Network and Bell TV Receivers/DVRs**

Follow the steps below to run one Check Switch test on each connected receiver and DVR.

*NOTE: Once the receivers/DVRs are set up, you can switch satellites as needed using the ACU front panel buttons, web interface, or the KVH TracVision HD7 iPhone/iPod touch app.*

- a. Ensure the antenna has an unobstructed view of the sky.
- b. Using the receiver's remote control (and a connected television), go to the "Point Dish/Signal Strength" screen (press MENU, 6, 1, 1 on most receiver models).
- c. Choose Check Switch, then press SELECT.
- d. Choose Test (DISH Network) or Check (Bell TV), then press SELECT.
- e. Wait up to 10 minutes for the test to complete and the receiver's Program Guide to load. Once complete, the Check Switch displays the current satellite, followed by "OK."
- f. Using the receiver's remote control, select the Program Guide to ensure it has loaded properly.

### **DIRECTV Latin America and Legacy Non-SWM DIRECTV Receivers/DVRs**

- g. Using the receiver's remote control (and a connected television), set the Satellite DISH Type to "Round." If you are configuring a legacy DIRECTV receiver, be sure to also choose "Multiswitch."



# ACU Menu Structure

## Appendix

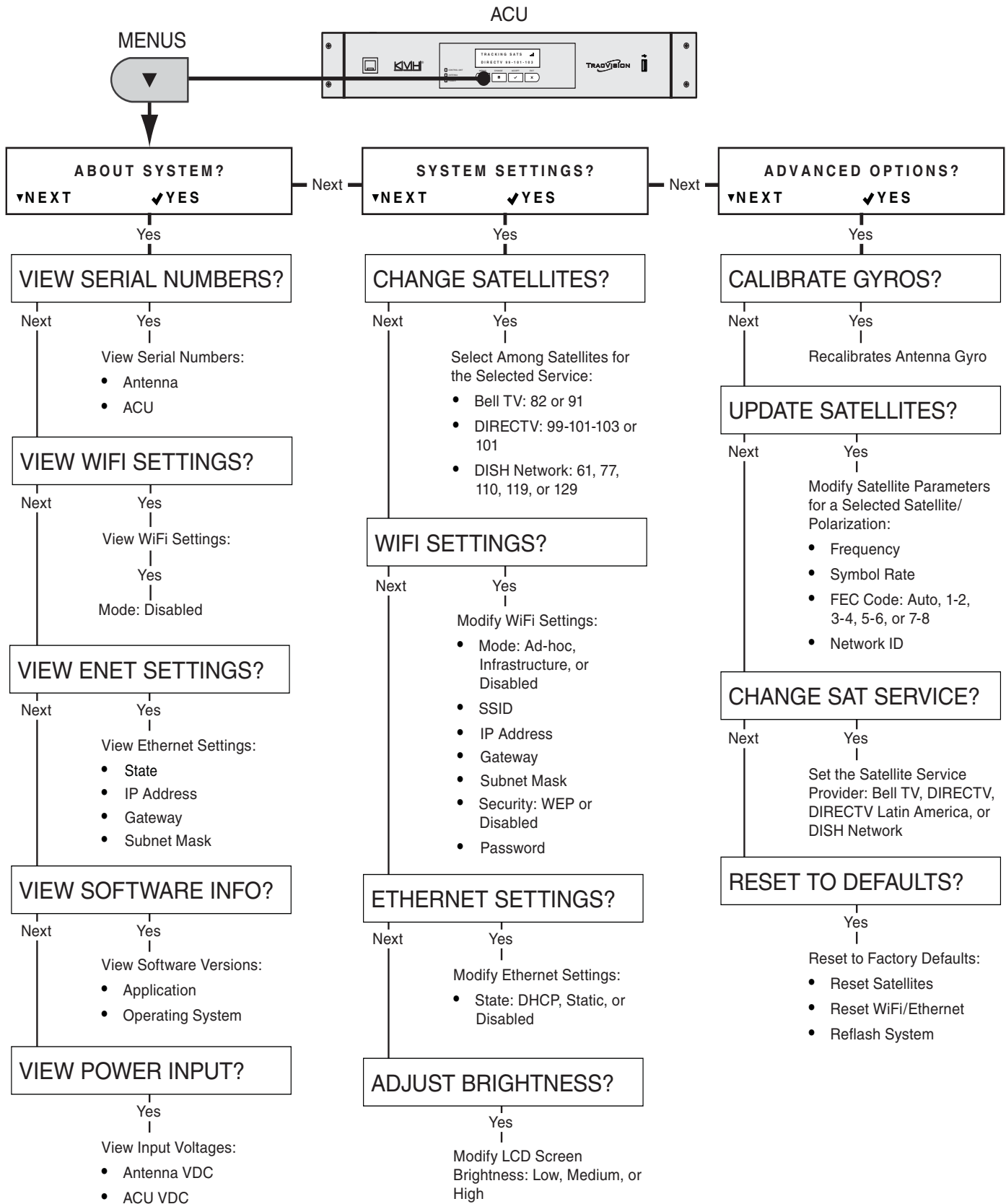



[www.kvh.com](http://www.kvh.com)



---

**KVH Industries A/S**  
*EMEA Headquarters*  
Kokkedal, Denmark  
Tel: +45 45 160 180 Fax: +45 45 160 181  
E-mail: [info@emea.kvh.com](mailto:info@emea.kvh.com)

**KVH Industries, Inc.**  
*World Headquarters*  
Middletown, RI U.S.A.  
Tel: +1 401 847 3327 Fax: +1 401 849 0045  
E-mail: [info@kvh.com](mailto:info@kvh.com)

**KVH Industries Pte Ltd.**  
*Asia-Pacific Headquarters*  
Singapore  
Tel: +65 6513 0290 Fax: +65 6472 3469  
E-mail: [info@apac.kvh.com](mailto:info@apac.kvh.com)